

# PC

# MAGAZINE

www.pcmag.com

## NEW ANTISPAM TOOLS



## NEW MUSIC PLAYERS GUN FOR THE IPOD



## 5 ESSENTIAL TIPS FOR DEGUNKING WINDOWS

## ALL-IN-ONE PRINTERS

THE INDEPENDENT GUIDE TO TECHNOLOGY

AUGUST 17, 2004

**Our Annual Reader Survey**

# The Best & Worst

## Plus Back-to-School PCs

## 22 Notebooks & Desktops for Fall

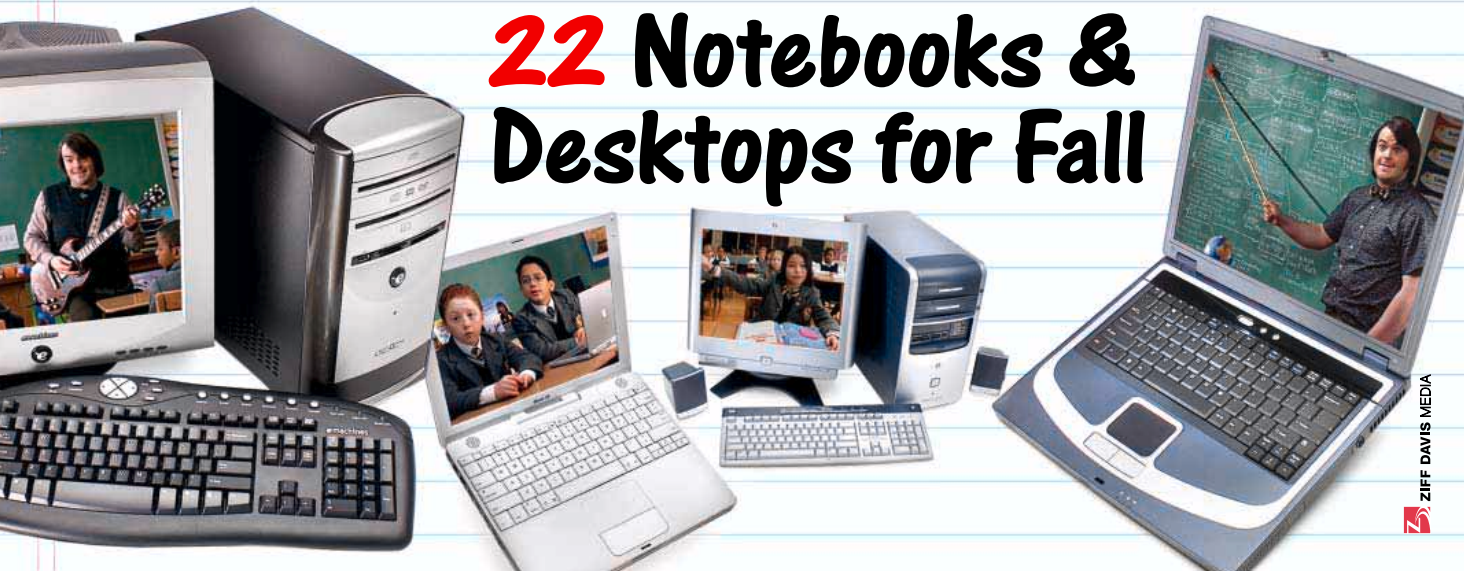

Cum Laude **by design.**



**Toshiba recommends  
Microsoft® Windows® XP.**

## Satellite® M35-S456 Special Edition

**Advanced graphics.  
Exceptional sound.**

Intel® Centrino™ Mobile Technology  
– Intel® Pentium® M processor<sup>1</sup> 735  
(1.70GHz processor,<sup>1</sup> 2MB L2 cache,  
400MHz FSB)  
– Intel® 855 chipset  
– Integrated Wireless LAN:  
Intel® PRO/Wireless  
Network Connection (802.11b/g)<sup>4</sup>  
Microsoft® Windows® XP Home  
Microsoft® Office OneNote™ 2003  
A \$199 value (MSRP)  
512MB DDR SDRAM  
80GB<sup>2</sup> hard drive  
DVD SuperMulti optical drive  
15.4" diagonal WXGA TFT display<sup>3</sup> with  
TruBrite™ screen technology  
High-quality Video Engine  
NVIDIA® GeForce™ FX Go5200  
with 64MB video memory  
10/100 Ethernet and V.92/56K modem<sup>5</sup>  
Limited warranty:<sup>6</sup> 1-year parts and labor  
1-year battery  
Toshiba ConfigFree™ software  
Three months of AOL® membership<sup>7</sup>  
Part #: PSM33U-001001

**\$1,999**

**Jump Code:  
JAHC-M35S456**

**Popular accessories:**  
Toshiba 12-Cell High-Capacity Li-Ion  
Battery Pack \$149

**Limited-time offers:**  
Order direct from Toshiba by 9/30/04

Toshiba 15.4" Nylon Case just \$29  
with notebook purchase (a \$20 savings)

3-Year SystemGuard® Protection + 2nd/3rd Year  
Warranty Extension \$199



- **Power** Intel® Centrino™ Mobile Technology delivers greater processing power on the go
- **Performance** Microsoft® Windows® XP Home lets you work smarter and connect to the Internet
- **Flexibility** Burn movies or data with the DVD SuperMulti drive that supports DVD-R/RW, DVD+R/+RW and DVD-RAM formats
- **Perspective** View DVD movies with theater style or work on extra wide spreadsheets on the 15.4" diagonal WXGA display
- **Clarity** With TruBrite™ screen technology for exceptional image brightness and the High-quality Video Engine for superior video playback – experience higher contrast, smoother motion, richer color and greater detail

**Order direct today!  
Call 888-241-5880**

**or visit [toshibadirect.com/pcmag817](http://toshibadirect.com/pcmag817)**

1. Central Processing Unit ("CPU") Performance Disclaimer: CPU performance in your computer product may vary from specifications under the following conditions: a. use of certain external peripheral products; b. use of battery power instead of AC power; c. use of certain multimedia games or other applications outside the range of 5°C to 30°C (41°F to 86°F) or >25°C (77°F) at high altitude (all temperature references are approximate and may vary depending on the specific computer model) – please refer to your Resource Guide or visit the Toshiba website at [www.pcsupport.toshiba.com](http://www.pcsupport.toshiba.com) for details. To avoid risk of lost data, always make back-up copies of data by periodically storing it on an external storage medium. For optimum performance, use your computer product only under recommended conditions. Read additional restrictions under "Environmental Conditions" in your Resource Guide. 2. Actual storage capacity will also be less if the product includes pre-installed operating system and/or application software. Actual formatted capacity may vary. 3. Small bright dots may appear on your TFT display when displaying high-contrast images. 4. Network speeds may vary. Actual data transmission speeds may require you to purchase additional software, services or external hardware. Availability of public wireless LAN access points is limited. 5. Due to FCC limitations, speeds of 53Kbps are the maximum permissible transmission rates during download. Actual data transmission speeds may vary. 6. Limited warranty does not include damage to the laptop from fire, flood, theft, or other causes. 7. Membership fee, simply cancel before three month promotional period ends. Premium services carry surcharges, and communication surcharges may apply, including in Alaska, even during promotional period. Members may incur telephone charges on their phone bill, depending on their service plan. © 2004 Toshiba America Information Systems, Inc. All other trademarks are the property of their respective owners. Product specifications, configurations, prices, system/component/options availability are all subject to change without notice.

Satellite, Satellite Pro and SystemGuard are registered trademarks and ConfigFree and TruBrite are trademarks of Toshiba America Information Systems, Inc. and/or Toshiba Corporation. Intel, Celeron, Centrino, Intel Inside, Pentium, the Intel Celeron logo and the Intel Inside logo are trademarks of Intel Corporation. NVIDIA and GeForce are registered trademarks or trademarks of NVIDIA Corporation in the United States and/or other countries. All other trademarks are the property of their respective owners. Product specifications, configurations, prices, system/component/options availability are all subject to change without notice.

# Manage life at school with a notebook that works as hard as you do.

Put one of these great systems in your backpack. Or go online and build<sup>8</sup> the system that's right for you.



## Satellite<sup>®</sup> A60-S166

ATI<sup>®</sup> graphics and SRS TruSurround XT<sup>™</sup> at an affordable price.



## Satellite<sup>®</sup> A55-S3061

Multimedia features, sleek design.



## Satellite<sup>®</sup> A70-S256

Get the power of an Intel<sup>®</sup> Pentium<sup>®</sup> 4 processor<sup>1</sup> and the clarity of a wide-screen display.

Mobile Intel<sup>®</sup> Pentium<sup>®</sup> 4 processor<sup>1</sup> 518 supporting Hyper-Threading Technology (2.80GHz processor,<sup>1</sup> 1MB L2 cache, 533MHz FSB)  
Microsoft<sup>®</sup> Windows<sup>®</sup> XP Professional  
Microsoft<sup>®</sup> Office OneNote<sup>™</sup> 2003  
A \$199 value (MSRP)  
256MB DDR SDRAM  
40GB<sup>2</sup> hard drive  
DVD/CD-RW optical drive  
15" diagonal active-matrix TFT display<sup>3</sup>  
ATI<sup>®</sup> MOBILITY<sup>™</sup> RADEON<sup>™</sup> 7000 IGP integrated graphics chipset with 64MB shared video memory  
Integrated Wi-Fi<sup>®</sup> (802.11b/g),<sup>4</sup> 10/100 Ethernet and V.92/56K modem<sup>5</sup>  
Limited warranty:<sup>6</sup> 1-year parts and labor, 1-year battery  
Toshiba ConfigFree<sup>™</sup> software  
Three months AOL<sup>®</sup> membership<sup>7</sup>  
Part #: PSA60U-01G01D

### \$1,249

**Jump Code: JAHC-A60S166**

#### Popular accessories:

Additional Toshiba 120W Global AC Adapter \$99

Memory upgrade — Kingston 256MB DDR SODIMM (part# KTT3311/256) \$90

#### Limited-time offers:

Order direct from Toshiba by 9/30/04

3-Year SystemGuard<sup>®</sup> Protection + 2nd/3rd Year Warranty Extension \$199

Intel<sup>®</sup> Centrino<sup>™</sup> Mobile Technology  
– Intel<sup>®</sup> Pentium<sup>®</sup> M processor<sup>1</sup> 715 (1.50GHz processor,<sup>1</sup> 2MB L2 cache, 400MHz FSB)  
– Intel<sup>®</sup> 852 chipset  
– Integrated Wireless LAN:  
Intel<sup>®</sup> PRO/Wireless Network Connection (802.11b/g)<sup>4</sup>  
Microsoft<sup>®</sup> Windows<sup>®</sup> XP Professional  
Microsoft<sup>®</sup> Office OneNote<sup>™</sup> 2003  
A \$199 value (MSRP)  
256MB DDR SDRAM  
40GB<sup>2</sup> hard drive  
DVD/CD-RW optical drive  
15" diagonal XGA TFT display<sup>3</sup>  
Intel<sup>®</sup> integrated graphics chipset  
10/100 Ethernet and V.92/56K modem<sup>5</sup>  
Limited warranty:<sup>6</sup> 1-year parts and labor, 1-year battery  
Toshiba ConfigFree<sup>™</sup> software  
Three months AOL<sup>®</sup> membership<sup>7</sup>  
Part #: PSA50U-03T030

### \$1,379

**Jump Code: JAHC-A55S3061**

#### Popular accessories:

Toshiba 12-Cell High-Capacity Li-Ion Battery Pack \$169

Memory upgrade — Kingston 256MB DDR SODIMM (part# KTT3311/256) \$90

#### Limited-time offers:

Order direct from Toshiba by 9/30/04

Mini-Mouse, USB Hub, 128MB Key and Arcsoft Software \$69

3-Year SystemGuard<sup>®</sup> Protection + 2nd/3rd Year Warranty Extension \$199

Mobile Intel<sup>®</sup> Pentium<sup>®</sup> 4 processor<sup>1</sup> 532 supporting Hyper-Threading Technology (3.06GHz processor,<sup>1</sup> 1MB L2 cache, 533MHz FSB)  
Microsoft<sup>®</sup> Windows<sup>®</sup> XP Professional  
Microsoft<sup>®</sup> Office OneNote<sup>™</sup> 2003  
A \$199 value (MSRP)  
512MB DDR SDRAM  
60GB<sup>2</sup> hard drive  
DVD/CD-RW optical drive  
15.4" diagonal WXGA TFT display<sup>3</sup>  
ATI<sup>®</sup> MOBILITY<sup>™</sup> RADEON<sup>™</sup> 9000 IGP integrated graphics chipset with 64MB shared video memory  
Integrated Wi-Fi<sup>®</sup> (802.11b/g),<sup>4</sup> 10/100 Ethernet and V.92/56K modem<sup>5</sup>  
Limited warranty:<sup>6</sup> 1-year parts and labor, 1-year battery  
Toshiba ConfigFree<sup>™</sup> software  
Three months AOL<sup>®</sup> membership<sup>7</sup>  
Part #: PSA70U-00D006

### \$1,499

**Jump Code: JAHC-A70S256**

#### Popular accessories:

Toshiba 12-Cell High-Capacity Li-Ion Battery Pack \$169

#### Limited-time offers:

Order direct from Toshiba by 9/30/04

3-Year SystemGuard<sup>®</sup> Protection + 2nd/3rd Year Warranty Extension \$199

Toshiba Backpack just \$39 with new notebook purchase (a \$30 savings)

with special effects; d. use of standard telephone lines or low-speed network connections; e. use of complex modeling software, such as high-end computer-aided design applications; f. use of computer in areas with low air pressure (high altitude >1,000 meters or >3,280 feet above sea level); g. use of computer for details; CPU performance may also vary from specifications due to design configurations. Under some conditions, your computer product may automatically shut down. This is a normal protective feature designed to reduce the risk of lost data or damage to the product when used outside recommended product Resource Guide. Contact Toshiba Technical Service and Support for more information. 2. Gigabyte (GB) means 1,000 x 1,000 x 1,000 = 1,000,000,000 bytes using powers of 10. The computer operating system, however, reports storage capacity using powers of 2 for the definition of 1 GB = 1,024 x 1,024 x 1,024 when you turn on your PC. Your display contains an extremely large number of thin-film transistors (TFT) and is manufactured using high-precision technology. Any small bright dots that may appear on your display are an intrinsic characteristic of the TFT manufacturing technology. 4. Wireless connectivity and some will vary depending on line conditions. 6. Limited warranty terms are available at [www.warranty.toshiba.com](http://www.warranty.toshiba.com). 7. Three months of AOL<sup>®</sup> membership included with the purchase of a Toshiba Satellite<sup>®</sup> or Satellite Pro<sup>®</sup> PC. Availability may be limited, especially during peak times. TO AVOID BEING CHARGED A MONTHLY on their location and calling plan, even during promotional period. Available to new AOL<sup>®</sup> members in the United States, age 18 or older; a major credit card or checking account is required. 8. Configuration: Configuring your notebook (with software or otherwise) takes an additional 5–10 working days.

or registered trademarks of Intel Corporation or its subsidiaries in the United States and other countries. Microsoft and Windows are registered trademarks and OneNote is a trademark of Microsoft Corporation in the United States and/or other countries. Wi-Fi is a registered certification mark of the Wi-Fi Alliance. change without notice. Reseller/Retailer pricing may vary. © 2004 Toshiba America Information Systems, Inc. All rights reserved.



## Satellite® A60-S1662

### ATI® graphics and SRS TruSurround XT™ at an affordable price.

Intel® Celeron® D processor<sup>1</sup> 325 (2.53GHz processor,<sup>1</sup> 256KB L2 cache, 533MHz FSB)

Microsoft® Windows® XP Home  
Microsoft® Office OneNote™ 2003

A \$199 value (MSRP)  
256MB DDR SDRAM

30GB<sup>2</sup> hard drive  
DVD/CD-RW optical drive

15" diagonal XGA TFT active-matrix display<sup>3</sup>  
ATI® MOBILITY™ RADEON™ 7000 IGP

integrated graphics chipset with 64MB  
shared video memory

Integrated Wi-Fi® (802.11b/g)<sup>4</sup> 10/100  
Ethernet and V.92/56K modem<sup>5</sup>

Limited warranty:<sup>6</sup> 1-year parts and labor,  
1-year battery

Toshiba ConfigFree™ software  
Three months of AOL® membership<sup>7</sup>  
Part#: PSA60U-01V01E

# \$999

**Jump Code: JAHC-A60S1662**

### Popular accessories:

An additional Toshiba

High-Capacity 12-Cell  
Li-Ion Battery Pack \$169

Memory upgrade –  
Kingston 256MB DDR  
SODIMM (part# KTT3311/256) \$90

### Limited-time offers:

Order direct from Toshiba by 9/30/04

Toshiba 15.4" Nylon Case just \$29  
with notebook purchase  
(a \$20 savings)

3-Year SystemGuard® Protection + 2nd/3rd  
Year Warranty Extension \$199

### Add a Toshiba SystemGuard® warranty extension

SystemGuard® Accidental Damage Coverage provides security against accidental damage for Toshiba's notebook computers.

# TOSHIBA

**Toshiba recommends  
Microsoft® Windows® XP.**

### Start the semester with an edge.

Toshiba notebooks and accessories will help you make the most out of your school year. In class. In your room. Or on the go.

**Buy direct from Toshiba  
and take advantage of these  
limited-time back-to-school  
offers when you order by  
9/30/04:**

### Free EPSON® printer

with purchase of  
a new notebook  
(after \$99 mail-in rebate).

Taxes and shipping charges still apply.



### Free ground shipping

with any new notebook  
purchase of \$999 or more.  
Use offer code MAHC.

### 12 months same-as-cash financing.

For complete offer details visit  
[toshibadirect.com/pcmag817](http://toshibadirect.com/pcmag817)

**Order direct today!  
Call 888-241-5880**

or visit [toshibadirect.com/pcmag817](http://toshibadirect.com/pcmag817)

**Or visit a reseller or retailer  
for your back-to-school needs.**



*Introducing Apple's new*

*AirPort Express™ with AirTunes.™ This*

*ingenious 802.11g base station plugs directly into the*



*digital quality from your computer's iTunes® library straight to your home stereo, where music was meant to be heard in the first place.*

*freedom of wireless networking with you, anywhere. Amazingly, it also lets you wirelessly stream music in 100% pristine*

*Internet and your printer. And it's so small, it easily fits in your laptop bag and lets you take the*

*wall, works with your PC or Mac® and lets you wirelessly connect to the*

Microsoft  
Your potential. Our passion.™



NAME

Mr. 50% Fewer  
Helpdesk Calls

**GAMEWORKS**



"So much of the infrastructure management is automated, it frees us up to build the foundation we need for growth and expansion."

**Mike Pettigrew**

Manager, Technical Services, *GameWorks*

**Make a name for yourself with Windows Server System.**

Microsoft Windows Server System makes infrastructure easier to manage for the eight-person IT staff at GameWorks, a high-tech entertainment and restaurant chain. Here's how: By using Windows Server 2003, they can prevent end users from installing unauthorized software, and make it easier to restore lost files. This reduced helpdesk calls by 50 percent, and gave them more time to focus on new projects and manage their growth. Software that's easier to manage is software that helps you do more with less. Get the full GameWorks story at [microsoft.com/wssystem](http://microsoft.com/wssystem)



Windows Server System™ includes:

Server OS	Windows Server™
Operations Infrastructure	Systems Management Server
	Operations Manager
	Internet Security & Acceleration Server
	Windows® Storage Server
Application Infrastructure	SQL Server™
	BizTalk® Server
	Commerce Server
	Host Integration Server
Information Work Infrastructure	Exchange Server
	Content Management Server
	Office SharePoint™ Portal Server
	Office Live Communications Server



FIND MEMORY

DIGITAL MEDIA

HYPERX

VALUERAM

SPECIALS

### Find ValueRAM Memory

Select the memory specification you require from the list below, then click FIND:

DDR memory



Additional search options:

- By Motherboard
- By Part Number

SPOTLIGHT

# FREE SHIPPING

on all orders

See website for details.



## Get ValueRAM™

Kingston's high-quality, cost effective generic memory solution.



# \$15

OFF

PC2700 or PC3200  
256 MB DDR

with mail-in rebate

# \$15

OFF

PC2700 or PC3200  
512 MB DDR

with mail-in rebate

## Check out our specials at [www.shop.kingston.com/pcmagazine](http://www.shop.kingston.com/pcmagazine)

\*Offer valid in the United States only while supplies last. LIMIT ONE unit, per part number (ECC product not eligible), per customer for the promotional period. Product is not intended for resale. Offer valid July 1, 2004 through July 29, 2004. See rebate form for complete terms and conditions pertaining to the rebate. This offer cannot be combined with any other promotion, discount or rebate and is subject to change at any time at Kingston's sole discretion. Check web site for most current price and availability.



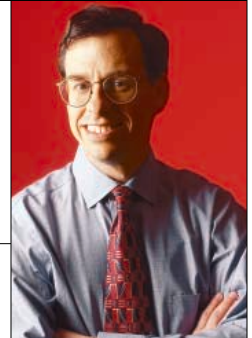

# Forward Thinking

## What's Wrong with Tech Support?

The reliability of PCs is getting better, but tech support is getting worse. That's the conclusion we draw from this year's reader satisfaction survey, starting on page 76. We used to call the survey "Service and Reliability," but over the years we've broadened it by asking readers more questions about overall satisfaction and the likelihood of their recommending particular vendors to other buyers.

The scores for overall satisfaction and reliability are similar to last year's survey: Our readers score almost all the vendors in the *very good* range on both counts. Most important, the percentage of machines needing repairs continues to drop—from 28 percent of desktops in 2002

to 17 percent in 2004. (Only 10 percent of the Apple desktops needed repairs.) At least part of that improvement is due to Windows XP making systems more stable. Vendors have also reduced returned products by choosing more reliable components.

But all is not well. The average satisfaction ratings for both tech support and repairs have dropped dramatically since last year. In other words, your machine was less likely to need support or repairs this year, but if it did, you were likely to be dissatisfied. Many readers complained about poor phone support—especially reps who didn't speak English

well—and made negative comments about offshore support. I don't oppose outsourcing in general, but I do believe that PC vendors have a responsibility to provide effective technical support. In this area, they are letting us down.

Nearly all the vendors tell us, as they do every year, that tech support is improving. But the numbers just don't show it. Let's all make sure the vendors know that we expect them to do better.

READER SATISFACTION	DESKTOPS			NOTEBOOKS		
	2002	2003	2004	2002	2003	2004
Overall	7.8	8	7.8	7.7	8	8
Reliability	7.9	8.1	8	7.9	8.2	8.3
Tech support	6.5	7	6.3	6.4	7.2	6.1
Repairs	6.4	7.4	6.7	6.2	7.2	6.6
Percent needing repairs	28%	24%	17%	21%	21%	19%

Except where noted, average scores are on a scale of 1 to 10, where 10 is best.

### PC SATISFACTION SCORES

Apple customers remain the most satisfied computer users. Of course, they almost have to be more loyal, because switching to or from Apple is more difficult than

moving among vendors of Windows-based machines. Nevertheless, Apple shows a big decrease in machines needing repairs. The improved quality of Mac OS X and the retirement of the Cube may be significant factors. Other vendors that do well include Dell in desktops and servers and IBM in notebooks. Also, locally built and self-built machines continue to score highly.

One area of concern is servers. For the past several years, satisfaction with them has been higher than with desktops and notebooks. But this year the scores have dropped significantly, from 8.4 last year to 7.9 this year. For more details, see the survey results on page 87.

**PC vendors have a responsibility to provide effective technical support, and they are letting us down.**

## Online Protection: Why Legislation Fails

The Supreme Court's recent decision to reject the Child Online Protection Act (COPA) was the right one. We should, of course, protect our children from filth on the Internet, but COPA raises First Amendment issues and could prevent people from reaching legitimate sites. The American Civil Liberties Union (ACLU) and several other groups have already challenged it. But the biggest reason why COPA should be stopped is simple: It can't possibly work. Technology remains our best means of blocking inappropriate Web sites.

It seems as if the only reason Congress passes laws like COPA is so our senators and representatives can

pretend they're doing something to combat Internet pornography. Doing so looks good to their constituents. But Congress had to know even before COPA was approved that it would end up in the courts for years and wouldn't solve the problem. (The law was enacted in 1998, but has never been enforced because of challenges to its constitutionality.)

COPA authorizes criminal penalties of up to \$50,000 per day for Internet sites that make pornography



# Forward Thinking

MICHAEL J. MILLER

**Neither software nor legislation is ever a substitute for an involved parent.**

available to those younger than 17. The Supreme Court ruling sends the case back to the federal district court, with instructions that the government show why such penalties would be more effective than the voluntary use of filtering software. Essentially, the Court said the government must demonstrate that criminal penalties were the “least restrictive alternative” to accomplish the goal. It seems unlikely that the government will be able to meet this requirement.

More important for the government’s case, COPA would not affect Web sites hosted outside the U.S. Software filters, however, block Web sites wherever they are hosted. Filtering software isn’t perfect, but it has improved significantly over the past few years. (For reviews, see our issue of August 3.) Any sufficiently motivated child can get around filters, but that’s irrelevant. Filters help draw the lines for kids, and more crucially, prevent them from accidentally

going to inappropriate sites. Some of the worst offenders are sites whose URLs are misspellings of popular sites for children.

Yet filters will never offer a complete solution. Parents need to talk to their children about how to use the Internet, what is and is not acceptable, and what to do if they land at an inappropriate site. Just as important, parents need to monitor their children’s computer use and teach them how to behave online, stressing that they should never share personal information in chat rooms. Neither software nor legislation is ever a substitute for an involved parent.

In the high court’s majority opinion, Justice Anthony Kennedy wrote that filters “impose selective restrictions on speech at the receiving end, not universal restrictions at the source.” If the Supreme Court has figured that out, maybe there is hope yet for Congress.

## How Private Is Your E-Mail?

If you think your e-mail is private, think again. A federal district court recently ruled that protections under the federal Wiretap Act cover eavesdropping on live communications like phone conversations, but do not extend to stored communications, such as e-mail stored on a service provider’s computers. The decision involved an executive of Interloc, a now-defunct book-listing company, who was accused of violating the law by copying e-mails sent by Ama-

zon.com to book dealers who subscribed to Interloc’s e-mail service.

E-mail poses a threat to privacy because most of it goes through multiple servers before reaching the intended recipient. In many cases, copies are stored temporarily. As a result, multiple copies of an e-mail may exist, and all are potentially vulnerable. Most of us accept the scanning of e-mail for viruses, but we also expect some privacy.

## Public Names, Public Numbers

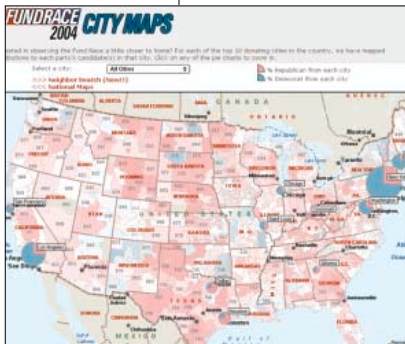

What do Bill Gates, Steve Ballmer, Michael Dell, Carly Fiorina, and Sam Palmisano have in common? They all run well-known high-tech companies, and they’ve all contributed \$2,000 to the George W. Bush reelection campaign. (Gateway’s Ted Waitt gave \$2,000 to Lieberman.)

How do I know this? Candidates are required to disclose where they get their

contributions to the Federal Election Commission, which then posts the figures online. Another site, Fundrace.org, lets you search for donations by location; I was able to find the donations of these CEOs very easily. (In a cursory search, I didn’t find a tech CEO who had given to John Kerry.)

Similarly, I’ve heard discussions lately about whether drug companies should post the results of all their drug trials online. A good starting point

would be to update the National Institutes of Health’s ClinicalTrials.gov. And the Securities and Exchange Commission has recently agreed to post more of its comments on various filings.

This kind of access ensures at least some openness in government. But at some point, I start to wonder. On Fundrace, I could see my neighbors’ contributions, and I’m not sure that’s any of my business. Not everyone wants their home address and their donations made public.

The common theme in all these cases is the balance between privacy and openness. But we don’t yet have any sense of where to draw the line between beneficial openness and the desire to keep communications private. That’s something we as a society need to decide soon, or the line will be drawn for us.

**MORE ON THE WEB:** Join us online and make your voice heard. Talk back to Michael J. Miller in our opinions section, [www.pcmag.com/miller](http://www.pcmag.com/miller).

**YOUR CONNECTION IS FAST.  
BUT  
IS IT FAST, AND ORGANIZED,  
AND EASY, AND NEED WE ASK  
ABOUT COOL CONTENT?**



**High-Speed Internet Users MEET Your One-Stop Wonder.**

**Add AOL® for Broadband® on top of** your basic high-speed Internet connection, and get a whole lot more from your online experience. AOL for Broadband brings all the stuff you want to one place. From live, original concerts to on-demand sports highlights, from Parental Controls to a personal firewall, and from e-mail to AOL® Bill Pay, it's right there – and it all works together – for an easier, more organized experience. So high-speed Internet users

**MEET**



**To sign up, call 1-888-AOL-4-YOU or visit [aol.com](http://aol.com)**

Requires purchase of a high-speed connection. High-speed connections not available in all areas. Personal firewall requires separate download at AOL Keyword: Firewall Express. Must be 18 or older to register; major billing method required. America Online, AOL, the Running Man Icon and the Triangle Logo are all registered trademarks of America Online, Inc. AOL for Broadband is a trademark of America Online, Inc. © 2004 America Online, Inc. All rights reserved.

It's your image.  
Do more with it.



- High performance color printing with lowest cost per page among printers in its class\*
- Network-ready, wired and wireless options and solutions
- Built-in auto-duplexing for two-sided printing; 850-sheet capacity with optional cassette
- Free 1-year on-site service program included\*\*

### Samsung's new CLP-500 Series Color Laser Printers.

It's your image. And our reputation. So at Samsung Electronics, we engineer our color printers around the productivity needs of business. We have hundreds of engineers whose entire focus is exploring new color technologies. And with ownership of the entire manufacturing, technology, design and development process, we can offer new solutions faster and more affordably than other printer providers. The results can be seen in our new CLP-550 color laser, which delivers photo-quality on plain paper, handles two-sided tasks with ease, and comes with print performance and paper capacities never before seen in its class. It's one of many solutions to come from Samsung Electronics, a company taking color and what it can do for you, to a whole new level. **Think. Print. Lead.**



..... Visit [www.samsungusa.com/printer](http://www.samsungusa.com/printer) or call 1-800-SAMSUNG

Available at:    

**SAMSUNG**

## 25 Editors' Choices

A comprehensive list of our current picks in nearly 100 categories.

## 30 First Looks

- 30 ChoiceMail One 2.52
- 31 iHateSpam 4.0.426
- 32 MailFrontier Desktop 4.0
- 32 SpamBully 2.0
- 32 Spam Shredder 1.5
- 34 Apple iPod 40GB
- 34 Creative Nomad Zen Xtra 60GB
- 35 iRiver HI40 ▶
- 35 Rio Karma
- 36 HP Media Center PC m1050y ▶
- 36 Microtel SYSWM8001
- 37 Paint Shop Photo Album 5
- 37 Nelson Email Organizer Pro 3.0
- 38 Gmail
- 38 PentaSuite 7.1
- 39 JVC MP-XV841 Mini Note PC ▼
- 39 Delphi XM Roady2
- 42 Tapwave Zodiac 1 ▲
- 42 Nokia N-Gage QD
- 43 Kyocera Finecam M410R
- 43 Olympus Camedia C-770 Ultra Zoom
- 44 NEC MultiSync LCD2060NX
- 44 Envision EN9250
- 46 Gordano Messaging Suite
- 46 Scalix Email and Calendaring Platform 9.0



### ALSO IN THIS ISSUE

- 51 Feedback
- 132 Backspace

### COVER STORY

76

# 17th Annual Reader Satisfaction SURVEY

Many companies are sending tech support to South Asia to save money. But has customer satisfaction gone south as well? We turned to you, our readers, to tell us what you think of the quality, reliability, and support behind the desktops, notebooks, and servers that you're using.

### PCs

## 91 Back-to-School PCs

Making the grade these days may depend on making a wise PC buying choice. Whether you're college bound or hoping your little one gets more from grade school, we help you decide which laptop or desktop makes the most sense for your dollar.

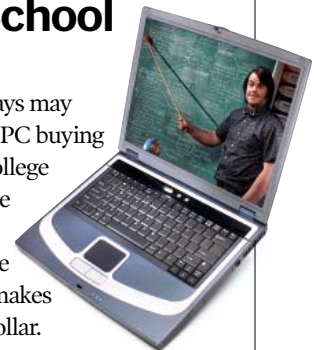

### ON THE COVER

Annual Reader Survey:  
The Best and Worst  
page 76

Back-to-School PCs  
page 91



New Antispam Tools page 30

New Music Players page 34

5 Tips for Degunking Windows page 60

All-in-One Printers page 107

## MULTIFUNCTION PRINTERS

### 107 All-in-Ones: One for All

Ink jet printers that also copy, scan, and fax are all the rage, mainly because they're now affordable—at prices as low as \$100—and they save precious desktop space. We review and rigorously test nine models, focusing on each one's cost per page and photo production quality.



## PRINT SERVERS

### 113 Unleash Your Printer

Thanks to the Wi-Fi revolution, sharing printers is easier than ever. Wireless print servers allow your printer to talk to any computer on your wireless network. We take a look at six of these devices for homes and small offices and two more complex devices for businesses.

## www.pcmag.com

### ONLINE EXTRAS

**All-in-One Devices:** Check out our online-only features table for the nine tested units that combine printer, copier, scanner, and fax capabilities.

**Wireless Print Servers:** Get a better look at these devices in our exclusive online slide show.

([www.pcmag.com/onlineextras](http://www.pcmag.com/onlineextras))

### FIRST LOOKS



New reviews every week!

Coming soon:

- ADS Tech USB Instant TV ▲
- Dell Laser Printer 1700n
- FilesAnywhere
- Keyspan USB print server
- WebSurveyor Pro Plus

([www.pcmag.com/firstlooks](http://www.pcmag.com/firstlooks))

### TOOLS YOU CAN USE

**Discussions:** Log on and participate! ([discuss.pcmag.com/pcmag](http://discuss.pcmag.com/pcmag))

**Downloads:** Check out our indexed list of utilities from A to Z.

([www.pcmag.com/utilities](http://www.pcmag.com/utilities))

### EXCLUSIVE COLUMNS



DVORAK ONLINE

► Each Monday, John C. Dvorak gives you his take on what's happening in high tech today. Visit [www.pcmag.com/dvorak](http://www.pcmag.com/dvorak).

ULANOFF ONLINE

► And each Wednesday, Lance Ulanoff puts his own unique spin on technology. Visit [www.pcmag.com/ulanoff](http://www.pcmag.com/ulanoff).



## EXTREME TECH™

Coming up:

- Build an all-around PC for \$1,500
  - Build your own LAN party room
  - Motherboard chipset head-to-head
- ([www.extremetech.com](http://www.extremetech.com))

## 19 Pipeline

- 19 Apple tames its new Tiger OS.
- 19 Virtual reality meets the military.
- 19 Microsoft patents the human body.
- 20 Projector technology that watches you.
- 20 IM: The next security threat?
- 20 The RIAA and your fingerprints.
- 22 **COMING ATTRACTIONS:** Alera DVD/CD Shredder Plus, Apple Cinema Displays, Motorola A630, and more.



## 60 Solutions

- 60 **Degunking Your PC:** Digital "gunk" can bring your computer to its knees. Here are our top five ways to make your PC faster and more reliable.
- 64 **Hardware:** Our expert tells you how and when to use the RAW format, which gives digital photographers unprecedented control over image processing.
- 66 **Security Watch:** If malware knocks you off-line, you can still turn the tables on it with just "stone tools" and your wits.
- 68 **Enterprise:** A digital asset management system helps Scripps Networks deliver television shows on demand to viewers.
- 73 **User to User:** How to read e-mail more safely, merge letters to large e-mail lists without their being rejected as spam, and more.

## Opinions

- 7 Michael J. Miller: Forward Thinking
- 53 Bill Machrone
- 55 John C. Dvorak
- 57 John C. Dvorak's Inside Track
- 59 Bill Howard

## 128 After Hours

- 128 **Cool School Tools:** It's time to gear up for the classroom again. Learn how to help your kids get an edge in school with the best new educational gadgets and software.
- 130 **Gear & Games:** PopCap's AstroPop; Nero PhotoShow Elite; Splinter Cell; Pandora Tomorrow; the Antec Aria SFF case; the Creative MuVo Slim; strategy games.



# BANDWUSS:

▶ Person who has high-speed Internet access and doesn't download movies.



**Movielink**<sup>®</sup>

DOWNLOADABLE MOVIES ARE HERE. [MOVIELINK.COM](http://MOVIELINK.COM)

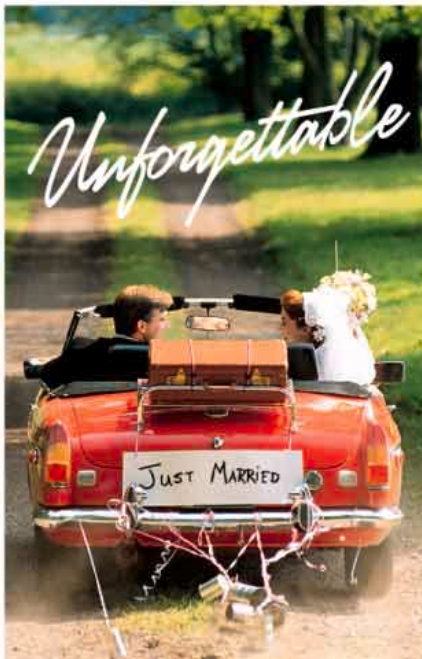

## Nero PhotoShow Elite

Treasure your unforgettable moments with the easy and complete photo experience.

**Manage, Make and Share** your photos, albums and musical slideshows. Capture, edit, and add effects, Clip Art, captions and text. Share online, burn CD or VCD, or order custom photo gifts and preserve your memories.

**All with unprecedented ease!**

[www.nerophotoshow.com](http://www.nerophotoshow.com)

Available online or at participating retailers.



**EDITOR-IN-CHIEF** Michael J. Miller

**EXECUTIVE EDITORS** Stephanie Chang, Ben Z. Gottesman, Carol Levin, Lance Ulanoff (Online)

**ART DIRECTOR** Richard J. Demler

**DIRECTOR, PC MAGAZINE LABS** Nick Stam

**SENIOR EDITORS** Jamie M. Bsales (First Looks), Vicki B. Jacobson (Online), Konstantinos Karagiannis (First Looks), Carol A. Mangis (After Hours, Special Projects), Sebastian Rupley (West Coast, Pipeline), Sharon Terdeman (Solutions)

**MANAGING EDITOR** Paul B. Ross

**ASSOCIATE EDITORS** Sarah E. Anderson, Sean Carroll, Jenn DeFeo, Matthew P. Graven, Davis D. Janowski, Jeremy A. Kaplan, Michael W. Muchmore, Sarah Pike, Laarni Almendrala Ragaza, Michael J. Steinhart

**ASSOCIATE MANAGING EDITOR** Michal Dluginski **COPY CHIEF** Glen Boisseau Becker

**STAFF EDITORS** Gary Berline (Online), Daniel S. Evans, Tony Hoffman, Michael Kobrin, Erik Rhey

**ASSISTANT EDITOR** Kyle Monson

**SENIOR WRITER** Cade Metz **COPY EDITORS** Erin Hollaway, Jessica Levine, Ann Ovodow, Steven Wishnia

**PRODUCTION MANAGER** Nicholas Cosmo **PRODUCTION EDITOR** Walter J. Konefal

**OFFICE ADMINISTRATOR** Rita Aprahamian **COMMUNICATIONS MANAGER** Anita Anthony

**INTERNS** Shasta Jean-Mary, Lawrence Judd, Rahul Kadam, Molly K. McLaughlin, Radmila Nizberg

**CONTRIBUTING EDITORS** Greg Alwang, Helen Bradley, Bruce Brown, Marge Brown, Sheryl Canter, John Clyman, Richard V. Dragan, John C. Dvorak, Les Freed, Sally Wiener Grotta, Bill Howard, Don Labriola, David Linthicum, Bill Machrone, Edward Mendelson, Jan Ozer, Charles Petzold, Alfred Poor, Neil Randall, Sarah L. Roberts-Witt, Winn L. Rosch, Barry Simon, Barry Simon, Luisa Simone, Craig Stinson, M. David Stone, Don Willmott

**SENIOR ASSOCIATE ART DIRECTOR** Cynthia Rhett **ASSOCIATE ART DIRECTORS** Sarah Crumb, Liana Zamora

**GRAPHICS DIRECTOR** David Foster **GRAPHIC ARTIST** Aaron Able **CONTRIBUTING PHOTOGRAPHER** Thom O'Connor

### PC MAGAZINE LABS

**DIRECTOR, OPERATIONS** Craig Ellison **TECHNICAL DIRECTOR** Richard Fisco

**LEAD ANALYSTS** Cisco Cheng, Laura Delaney, Sahil Gambhir, Oliver Kaven, Glenn Menin, Neil J. Rubenking, Joel Santo Domingo, Sascha Segan

**PRODUCT TESTING MANAGER** Charles Rodriguez **TECHNICAL ANALYSTS** Omar Cintron, Roy Goodwin, Joseph A. Guilbeau IV, William Pagan

**INVENTORY CONTROL COORDINATOR** Nicole Graham **INVENTORY CLERK** Alphonse Ragusa

### PC MAGAZINE ONLINE

**SENIOR PRODUCER** Yun-San Tsai **PRODUCER** Mark Lamorgese **ASSISTANT PRODUCER** Whitney A. Reynolds

**SENIOR DESIGNER** Donatella Pereira **COMMUNITY MANAGER** Jim Lynch **PRODUCT DATABASE MANAGER** Gina Suk

### EXTREMETECH

**EDITOR-IN-CHIEF, INTERNET** Jim Louderback **TECHNICAL DIRECTOR** Loyd Case

**SENIOR TECHNOLOGY ANALYST** Dave Salvator **TECHNOLOGY ANALYST** Jason Cross **SENIOR NEWS EDITOR** Mark Hachman

**SENIOR WEB PRODUCER** Robyn Peterson **ASSISTANT WEB PRODUCER** Dan Avery

**COMMUNITY MANAGER** Jim Lynch **TECHNICAL ADVISOR** Nick Stam

### CORPORATE PRODUCTION

**SENIOR ADVERTISING PRODUCTION MANAGERS** Milena Emery, Ivis Fundichely

### THE INDEPENDENT GUIDE

*PC Magazine* is the Independent Guide to Technology. Our mission is to test and review computer- and Internet-related products and services and report fairly and objectively on the results. Our editors do not invest in firms whose products or services we review, nor do we accept travel tickets or other gifts of value from such firms. Except where noted, *PC Magazine* reviews are of products and services that are currently available. Our reviews are written without regard to advertising or business relationships with any vendor.

### HOW TO CONTACT THE EDITORS

We welcome comments from readers. Send your comments to Internet address [pcmag@ziffdavis.com](mailto:pcmag@ziffdavis.com) or to *PC Magazine*, 28 E. 28th St., New York, NY 10016-7940. Please include a daytime telephone number. *PC Magazine's* general number is 212-503-5100. The West Coast Operations number is 415-547-8000. We cannot look up stories from past issues, recommend products, or diagnose problems with your PC by phone. An index of past issues is at [www.pcmag.com/previous\\_issues](http://www.pcmag.com/previous_issues). For a list of upcoming stories, browse [www.pcmag.com](http://www.pcmag.com). For a full description of who on staff covers what, go to [www.pcmag.com/whocoverswhat](http://www.pcmag.com/whocoverswhat).

If you are dissatisfied with a product advertised in *PC Magazine* and cannot resolve the problem with the vendor, write (do not call) Anne King, Advertising Department, at the above address. Please include copies of your correspondence with the vendor.

### SUBSCRIPTION INFORMATION

For subscription service questions, for address changes, or to order, please contact us: **Internet**, <http://service.pcmag.com> (for customer service) or <http://subscribe.pcmag.com> (to order); **telephone**, 800-289-0429 or 850-682-7624 in the U.S. and Canada, 303-604-7445 elsewhere; **mail**, *PC Magazine*, P.O. Box 54070, Boulder, CO 80322-4070 (please include your mailing label with any correspondence, as it contains information that will expedite processing); **fax**, 850-683-4094 in the U.S. and Canada, 303-604-0518 elsewhere; **e-mail**, [subhelp@pcmag.com](mailto:subhelp@pcmag.com) (please type your full name and the address at which you subscribe. **Subscriptions:** The one-year subscription rate is \$39.97. *PC Magazine* is published semimonthly, with occasional exceptions: A special issue may count as a subscription issue, a combined or expanded issue may count as two subscription issues, and there may sometimes be an extra issue. Outside the U.S., add \$36 per year for surface mail; U.S. funds only. Please allow four to six weeks for your first issue to arrive or for any changes in your subscription to take place. **Back issues:** Back issues are \$8 each in the U.S., \$10 each elsewhere. Prepayment is required. Contact customer service (above) for availability. **Mailing lists:** We sometimes make lists of our customers available to mailers of goods and services that may interest you. If you do not wish to receive their mailings, please write to us at *PC Magazine*, P.O. Box 54070, Boulder, CO 80322-4070.



Jeannie celebrates as she Elevates to new heights.



**We're More Than Just a Cart Company.** You may know us as the company with those "3 hefty guys on a cart". And you'd be right — we've spent 20 years making really strong carts, all with a Lifetime Warranty. But now we also have furniture like rack enclosures, electric lift tables, and work benches. So the next time you need a good furniture solution for your technology needs, contact us at [anthro.com](http://anthro.com) or **800.325.3841**. The hefty guys are still around, but there's so much more!



**ANTHRO**

**Technology Furniture®**

*– Fast & Friendly!*

# nu school

have everything you need  
for back-to-school?

## college checklist

- computer & Cityadvantage protection plan
- printer, paper, ink & printer cable
- ethernet card for computer, mouse & pad
- surge protector, cables & software
- blank CDs/DVDs or ThumbDrive & diskettes
- wireless and cordless phone & answering machine
- TV, stereo & speakers
- MP3 player, headphones & batteries
- digital camera & flash memory
- game system & games
- gift card for last-minute items



circuitcity.com



**SENIOR VICE PRESIDENT AND PUBLISHER** Timothy J. Castelli

**NATIONAL ASSOCIATE PUBLISHER** C. Wesley Walton

**EAST COAST AD DIRECTOR** Jason Webby

**BUSINESS DIRECTOR** John C. Hutchins

**MARKETING DIRECTOR** Mark Pope

**RESEARCH DIRECTOR** Stephen Riddle & Chris Stetson

**RESEARCH MANAGER** John Tsao

### ADVERTISING OFFICE

28 E. 28th St., New York, NY 10016-7940

Phone, 800-336-2423, 212-503-5100; fax, 212-503-5000

For advertising information go to [www.pcmagmedia.com](http://www.pcmagmedia.com).

For information on advertisers appearing in this issue, go to [www.pcmag.com/adindex](http://www.pcmag.com/adindex).

### SOUTHERN CALIFORNIA, AZ, NV, TX

Deborah Dembo 310-453-8855

### NORTHERN CALIFORNIA, NORTHWEST, UT, CO

Cristi E. Brown 415-547-8056

Andrew Donehower 415-547-8815

David Kaye 415-547-8810

### NEW YORK

Ian Owen-Ward 212-503-5110

Julie Zuckerman Kittredge 212-503-5029

### NEW ENGLAND, CANADA

Ian Owen-Ward 212-503-5110

### MIDWEST

Julie Lulu 773-739-9139

### DETROIT

Julie Zuckerman Kittredge 212-503-5029

### SOUTHEAST, MID-ATLANTIC STATES

Amy Jarratt 404-249-6646

### EAST COAST ACCOUNT EXECUTIVES

Andrew Guendjoian 212-503-5114,

Melissa Price 212-503-5422

### WEST COAST ACCOUNT EXECUTIVE

Andrew Wesley 415-547-8047

Mathias Bontaites 415-547-8240

### MARKETLINK, SOUTHWEST

Kathy Rosa, Marketlink Sales Director,  
212-503-8487

### MARKETLINK, SOUTHEAST

Stacey Harnick 212-503-5106

### MARKETLINK, NORTHEAST

Chris Thornton 212-503-5067

### MARKETLINK, NORTHWEST

Brooke Aloviz 212-503-4847

### EAST COAST SALES ASSISTANTS

Anne King, Nicole Krammer,  
Andrew Weissman

### WEST COAST SALES ASSISTANTS

Jennifer Meyer, Rebecca Reining

### DIRECTOR, SALES OPERATIONS

Tara Culleney

### DIRECTOR, CIRCULATION

Chris Ekizian

### DIRECTOR, RETAIL SALES

Bob Kerekes

### DIRECTOR, CREATIVE SERVICES

Bobby Sutton

### DIRECTOR, CONSUMER MARKETING

Chris Wilkes

### ADVERTISING SERVICES MANAGER

Laura Quirk

### MARKETING COORDINATOR

Michele Itzkowitz

### SALES DEVELOPMENT COORDINATOR

Matt Pfeffer

## ZIFF DAVIS MEDIA INC.

**CHAIRMAN & CEO** Robert F. Callahan

**PRESIDENT & COO** Bart W. Catalane

**CHIEF FINANCIAL OFFICER** Derek Irwin

**SENIOR EXECUTIVE VICE PRESIDENT, PUBLISHING OPERATIONS** Tom McGrade

**EXECUTIVE VICE PRESIDENT & EDITORIAL DIRECTOR** Michael J. Miller

**EXECUTIVE VICE PRESIDENT, GENERAL COUNSEL, & SECRETARY** Gregory Barton

**SENIOR VICE PRESIDENTS** Jasmine Alexander (Technology & Sales Operations), Timothy J. Castelli (PC Magazine Group), Chris Dobbrow (Corporate Sales & Publisher, *eWeek*), Larry Green (Business Development & Worldwide Licensing), Charles Mast (Circulation), Sloan Seymour (Enterprise Group), Dale Strang (Game Group), Jason Young (Internet)

**VICE PRESIDENTS** Ken Beach (Corporate Sales), Sarah DeCarlo (Database Marketing), Aaron Goldberg (Market Experts), Jim Hasl (Event Marketing Group), Julie Herness (Event Marketing Group), Tom Jessiman (VP and General Manager, 1UP.com), Michael Krieger (Market Experts), Charles Lee (Integrated Media), Jim Louderback (Editor-in-Chief, Internet), Eric Lundquist (Editor-in-Chief, *eWEEK*), Chris Maginn (Internet), Angelo Mandarano (Internet), Paul O'Reilly (Event Marketing Group), Ellen Pearlman (Editor-in-Chief, *CIO Insight*), Melinda Maginn Reilly (Integrated Media & Corporate Sales), Beth Repeta (Human Resources), Martha Schwartz (Custom/Conference Group), Pam Spector (Business Development & International Licensing), Tom Steinert-Threlkeld (Editor-in-Chief, *Baseline*), Stephen Sutton (Internet Audience Development), Eida Vale (Research & Market Intelligence), Stephen Veith (Publisher, *CIO Insight*), Monica Vila (Event Marketing Group)

**SENIOR DIRECTOR, MANUFACTURING** Carlos Lugo

**DIRECTOR, CORPORATE COMMUNICATIONS** Randy Zane

### PERMISSIONS, REPRINTS

For permission to reuse material in this publication or to use our logo, contact Ziff Davis Media's rights and permissions manager, Olga Gonopolsky, at [permissions@ziffdavis.com](mailto:permissions@ziffdavis.com), or by phone at 212-503-5438 or by fax at 212-503-5420. Material in this publication may not be reproduced in any form without written permission. For reprints, please contact Stella Valdez at FosterReprints: telephone, 866-879-9144; fax, 916-983-6762; e-mail, [svaldez@fostereprints.com](mailto:svaldez@fostereprints.com).

The following are registered trademarks of Ziff Davis Publishing Holdings Inc.: i-Bench, NetBench, PC DIRECT, PC Labs, PC MAGAZINE, PC MAGAZINE AWARD FOR TECHNICAL EXCELLENCE, PC MAGAZINE EDITORS' CHOICE, PC MagNet, ServerBench, WinBench, Winstone, and Ziff Davis Media's corporate logo. The following are trademarks of Ziff Davis Publishing Holdings Inc.: After Hours, Backspace, CPUmark, EasyComputing, ExtremeTech, First Looks, First Looks Plus, i-Bench, Lab Notes, Lab Tales, PC Bench, PC Labs Scorecard, PC Magazine At Home, PC Magazine CD, PC Magazine Extra, PC Magazine Marketlink, PC Solutions, PC Tech, Pipeline, Power Programming, Quick Clips, ScreenDemos, Tech Notes, and WinDrain. Other trademarks and trade names used throughout the publication are the property of their respective owners. Copyright © 2004 Ziff Davis Media Inc. All rights reserved. Reproduction in whole or in part without permission is prohibited.





imation



:: DVD-R

:: DVD+R

:: DVD-RW

:: DVD+RW

:: DVD-RAM

**PUT PHOTOS ON IT.  
PUT VIDEOS ON IT. PUT DATA ON IT.  
WE PUT OUR REPUTATION ON IT.**



With 4.7GB of storage capacity, a DVD can hold more than two hours of digital video, thousands of digital photos or MP3 music files, or huge presentations. It's rapidly becoming the most popular form of optical storage, and Imation has been leading the DVD revolution since the beginning. No matter what you put on an Imation DVD, our reputation for quality and technology leadership will already be there. Find out more at [www.imation.com/DVD](http://www.imation.com/DVD). **INSPIRING DIGITAL CONTENT**

Available online and at leading retailers nationwide:

Stores	Web			
Target	CDW.com	PCMall.com	Buy.com	OfficeMax.com
OfficeMax	Insight.com	PCConnection.com	Staples.com	Target.com

Medion recommends Microsoft® Windows® XP.

**MEDION**

**the smart choice for**

**performance, quality, and value**

**from one of Europe's leading PC suppliers**



**M<sup>3</sup> Composer 5100 available at Best Buy**

**Intel® Pentium® 4 processor 530 with HT Technology  
(1MB L2 Cache/ 800 MHz Front Side Bus/ 3.0 GHz)**

- Microsoft® Windows® XP Home Edition operating system
- 512 MB DDR RAM memory
- 160GB, 7200rpm SATA hard drive
- 8x DVD±RW drive
- 128 MB NVIDIA® GeForce™ FX 5300 graphics card
- Photo, video, and music software included



includes  
2.1 Flat Panel Speaker System  
with Powered Subwoofer,  
keyboard and mouse



**MEDION®**  
very clever

For more information visit us online at [www.medion.com](http://www.medion.com)

Intel, Intel Centrino, Intel Inside, the Intel Inside logo are trademarks or registered trademarks of Intel Corporation or its subsidiaries in the United States and other countries. All other company and product names herein may be trademarks and/or registered trademarks of their respective owners.

Microsoft and Windows are either registered trademarks or trademarks of Microsoft Corporation in the United States and/or other countries.

# PIPELINE

## TECHNOLOGY TRENDS & NEWS ANALYSIS

### Apple's Next Move

The upcoming Tiger version of Mac OS X soups up searching.

CONTINUING THE THEME of naming OSs after big cats, in late June Apple Computer debuted the fifth major version of Mac OS X, dubbed Tiger. CEO Steve Jobs showed a pre-release version of it with over 150 new features at the company's Worldwide Developer Conference in San Francisco. Tiger is slated to ship in the first half of 2005 and will sell for \$129.

A new systemwide search technology, called Spotlight, easily qualifies as Tiger's centerpiece. Spotlight does automatic, indexed searches, then organizes and displays the results by category, such as date or people.

The interface Spotlight uses (see the photo) is very similar to the one in Apple's iTunes music store, which lets you find songs by name, artist, or album. In his demonstration, Jobs proposed finding everything on a computer about someone named Bernard. When he typed in a Spotlight search, files appeared in lists, including Bernard-related presentations, documents, e-mails, and images. "I think a whole lot of people are going to stop using Finder," Jobs predicted, referring to the long-standing tool for searches found in Mac OSs.

Jobs also demonstrated a new version of



Apple's Safari Internet browser called Safari RSS (Really Simple Syndication). RSS news feeds—where you can view lots of headlines and story summaries at once—are already common on many Web sites. Safari RSS flips easily between RSS and standard views.

Although Tiger is still early in its development cycle, Apple developers are very focused on how systemwide information is stored and found. With storage capacities skyrocketing and Microsoft focusing on similar goals, expect to see big improvements in system searching across the board.—*Sebastian Rupley*



### I, Server

Would your body make a good network server? In late June, the U.S. Patent Office took the idea seriously enough to award Microsoft patent number 6,754,472—titled "method and apparatus for transmitting power and data using the human body." The original patent application came in April of 2000.

The patent describes using "the human body as a conductive medium over which power and data is distributed." It also refers specifically to coupling a power source to the body via a set of electrodes. Speakers, displays, watches, and keyboards can connect to the power source.

Microsoft is already a player in the wearable computing market with its services for smart watches, but they have not met with huge success.—*SR*

**FILL 'ER UP** Toshiba has developed a tiny fuel cell for digital audio players and other handheld devices. The company claims the thimble-size cell can power an MP3 player for 20 hours using 2cc's of methanol fuel. Expect to see it arrive in handhelds in 2005.

### In the Virtual Moment



YOU'RE A MILITARY officer with your gun drawn in a crowded square ordering screaming bystanders to stay away from a terrorist with a bomb strapped to his chest. He reaches for the bomb, and you shout instructions. The lights go up.

Video screens surrounding you go blank. And trainers tell you that you should have already fired a shot to the head.

Texas-based Virtra Systems installs 360-degree, photorealistic virtual reality rooms, which have been used for military, police, and Homeland Security training. The simulators use Pentium 4 systems to stream video and sound to high-definition projectors.—*SR*

### Net Calls on the Radar?

Voice over Internet Protocol (VoIP) calls, as offered by companies such as Skype and Vonage, can present some enormous cost advantages over phone calls. But relatively few Internet users even understand that voices can be carried over the Net.

Percentage of U.S. Internet users who have

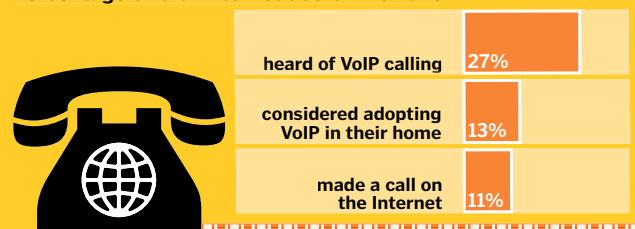

Based on surveys of 2,204 Internet users. Source: Pew Internet & American Life Project, June 2004.

## Casting a Magic Shadow

Your projector is showing PowerPoint slides, and you want to bring the audience's attention to a specific bar on a chart. You could step in front of the screen and simply point to the image; but then your body would be bathed in graphics like a bad 007 movie credit sequence, and you'd risk being blinded by the light.

Now you can park in front of the screen without a problem (see the photo and the ab-



sence of graphics on the model), thanks to the iSkia from iMatte. The iSkia looks like a second projector and connects your laptop and projector. The device then tracks your position, and when you step in front of the projected image it automatically creates a mask, casting a shadow on the screen to match your body. Move around and the shadow follows you. No more blinding light or distracting images.

The iSkia is capable of much more, however. For example, it can track the location of your hand, so you can manipulate the program data using gestures. The product is an offshoot of iMatte's background in television and cinema blue-screen technology. "We played a significant role in the effects revolution in those markets," says CEO Paul Vlahos. Sometimes, though, drama comes from avoiding the spotlight. —Alfred Poor

## The IM Security Threat?

WORRIES ARE MOUNTING about instant-messaging (IM) security. Citing two of the most notorious worms in recent years as evidence of how fast malicious code can travel, Symantec officials say the next big worm is likely to exploit flaws in IM clients and spread fastest of all.

"Code Red was able to infect every vulnerable machine on the Internet in 14 hours. Slammer did it in 20 minutes," says Eric Chien, chief of research at Symantec Security Response. "An IM threat could spread to a half a million machines in 30 or 35 seconds. We've seen vulnerabilities in every free IM client out there."

That's worrisome because IM clients are widely used on business machines. Of all U.S. companies, 26 percent use IM as an official corporate service and another 44 percent acknowledge that their employees use IM on their own, according to estimates from The Radicati Group.

Naturally, viruses can spread over IM in much the same way they spread over e-mail: via attachments. But this is a minor worry. The real danger is that IM is ripe for an attack involving a virus that exploits a specific software vulnerability to gain access to your machine without your doing anything.

How can you protect yourself? For one, you should run anti-virus software. Most engines have plug-ins for IM clients. And on the corporate side, Chien advises, businesses need to crack down on unauthorized use of IM within their walls and avoid the free IM clients. —Cade Metz



## SIGN O' THE TIMES

In a move that reflects how hard hit the technology industry has been in recent years, the annual Comdex trade show in Las Vegas has been called off. The IT-centric 2003 event attracted 40,000 attendees—far fewer than the 100,000-plus seen in previous years. Show organizers point to "marketing budgets that are at minimums." By contrast, the annual Consumer Electronics Show (CES) in Las Vegas earlier this year drew almost 130,000 technology executives and nearly 2,500 companies, well up from last year. —SR

## Dusting for Music Prints

IN THE FUTURE when you want to listen to the new U2 song, your fingers may have to do the walking—literally. Biometric firm VeriTouch has a scheme for a new breed of MP3 player that would use built-in fingerprint readers to unlock encrypted music tracks. The first design, dubbed the iVue (shown), would include a music player, a hidden fingerprint scanner, a cell phone, and Wi-Fi and Bluetooth wireless capabilities. Consumers, though, have resisted biometric scans because of privacy concerns.

"We want the end user to be anonymous," says VeriTouch CEO Gary Brant. "The finger-



prints stay encrypted on the device's hard drive." Brant emphasizes that the biometric fingerprints do not contain the same kind of data used in law enforcement and that the copyright protection scheme uses public and private keys to maintain privacy. As with the popular PGP system, music buyers would give out their public keys to online music stores. The merchant would

then encrypt purchases specifically for the customer, and the customer would use private keys—fingerprint scans—to unlock downloadable files.

VeriTouch has already demonstrated a prototype device to the Recording Industry Association of America. Ultimately, the record companies would have to adopt the technology and woo hardware manufacturers to include biometric readers in their players. Brant says the readers would add only about \$10 to the cost of a player. The question is, will music fans give record companies the finger? —John R. Quain

**STORAGE SHIFT** Following moves by Google and Yahoo! to vastly increase the free storage that's available to Web e-mail users, Microsoft's Hotmail division said users of its service will get 250MB of free storage—up from 2MB—starting this summer.



# SUMMER SPECIAL!

## HURRY! OFFER ENDS AUGUST 25 ON AMERICA'S DOMAIN NAME

**.US**  
DOMAIN FOR  
**\$2.99**  
PER YEAR  
LIMITED TIME OFFER!

<b>.US</b>	<b>\$2.99</b>	per year
<b>.COM</b>	<b>\$5.99</b>	per year
<b>.NET</b>	<b>\$5.99</b>	per year
<b>.INFO</b>	<b>\$5.99</b>	per year
<b>.NAME</b>	<b>\$5.99</b>	per year
<b>.ORG</b>	<b>\$5.99</b>	per year

Is your perfect domain name unavailable in .com? 1&1 has your solution... a .us domain! 1&1 makes the .us domain affordable for everyone at just **\$2.99 per year**. Most other Registrars charge more than four times that amount! But hurry, this incredible offer ends August 25, 2004.

3 MILLION CUSTOMERS HAVE ALREADY JOINED THE WORLD'S #1 WEB HOST



1.877.GO1AND1  
1AND1.COM

1&1

# COMING ATTRACTIONS

## Just Like the Movies

Apple continues to raise the bar on clean design and super functionality. The new **Apple Cinema Displays** (in 20-, 23-, and 30-inch sizes) showcase a very thin bezel in anodized aluminum and an incredibly responsive hinge for adjusting the display angle. Two FireWire 400 ports and two USB 2.0 ports ensure many connectivity possibilities, and an optional VESA mount lets you place the screen in unlikely places. But to use one of these superstars, you'll need a Power Mac G5 with an nVidia GeForce 6800 Ultra DDL graphics card.—*Mary E. Behr*  
\$1,299 direct and up. Apple Computer Inc., www.apple.com.



## Big, Durable Printouts

Those who enjoy creating banners, flyers, and the like are often thwarted by the elements. Take heart:

Espon's new printers, the **Epson Stylus C66** and the **Stylus C86**, use water-resistant, pigment-based DuraBrite ink. The C66 produces borderless 4-by-6 prints as well as text and graphics at up to 17 pages per minute (ppm) and up to 9 ppm in color. The C86 offers 4-by-6-inch, 8-by-10, and letter-size prints at up to 22 ppm in black and up to 12 ppm in color.—*MEB*  
C66, \$69 direct; C86, \$99. Epson America Inc., www.epson.com.



## Do-It-All Phone

Don't be fooled by the typical candy bar handset of the GSM-based **Motorola A630**: It opens like a book to reveal a full QWERTY keyboard for text messaging, e-mail, and IM. It also has a 4X zoom VGA camera and Bluetooth technology. Advanced messaging options include MMS (Multimedia Messaging Service), SMS, and POP3.—*MEB*

Price not yet set.  
Motorola Inc.,  
www.motorola.com.



## Rip Up Those CDs

You shred your important papers every time the Feds bang on your door; why not shred your incriminating CDs and DVDs as well? Alera Technologies' new **DVD/CD Shredder Plus** is a scary little machine that uses carbon steel blades and a 1.2-horsepower motor to cut DVDs, CDs, floppy disks, and credit cards into small, unusable strips, forever eliminating unauthorized use. The unit is HIPAA-compliant and includes a four-gallon container to catch the shards.—*MEB*  
\$99 street. Alera Technologies LLC,  
www.aleratec.com.



## Bring It All with You

For those of you who just can't leave home without your data, Kano Technologies has created the **Sure-FIRE800**, a pocket-size external hard drive. Measuring just 5.25 by 3.25 by 0.75 inches (HWD), it sports 5,400-rpm speed, an 8MB cache, and FireWire 800/400 and USB 2.0 connections. Compatible with both Windows and Mac, it comes with Dantz Retrospect Express backup software.—*MEB*  
20GB to 80GB, \$249 to \$399 direct. Kano Technologies Corp.,  
www.kanotechnologies.com.



## Keep Data Secure from Prying Eyes

Home and business users who need to keep data secure will be interested in the new **Micro Solutions Lock-Box**. This portable external hard drive features a fingerprint reader that allows access only to authorized users. Available in 80GB, 120GB, and 200GB capacities, the drive can be formatted as a single partition or as up to seven logical drives that can each have a distinct authorized user.—*Jamie M. Bsales*  
\$199 list and up. Micro Solutions Inc., www.micro-solutions.com.



For more new products see [www.pcmag.com/productbulletin](http://www.pcmag.com/productbulletin)

# SUMMER SPECIAL!

## PROFESSIONAL ALL-INCLUSIVE HOSTING SMALL PRICE, BIG PERFORMANCE

**\$4<sup>99</sup>**  
PER MONTH

**NO SETUP FEE!**

### HOME PACKAGE

Perfect for Small Businesses

#### INCLUDES 1 DOMAIN

##### PACKAGE FEATURES

- 500 MB of Web space
- 1 FTP account
- 5,000 MB monthly transfer volume
- 1&1 Control Panel
- Optional Dedicated SSL Certificate
- Hosted on 1&1 Linux platform

##### MARKETING TOOLS

- 1&1 Chat - 1 channel
- 1&1 WebStatistics

##### SITE-BUILDING TOOLS

- WebsiteCreator for 12 pages
- Full version software worth \$550
- FrontPage 2002 extensions
- CGI library

##### DOMAIN NAMES

- Includes 1 domain (.com .net .org only)
- Handling of unlimited domain names
- DNS Management
- Point 50 external domains to 1&1
- 5 subdomains

##### E-MAIL

- 50 POP3 e-mail accounts
- Aliases, auto-responders, forwarding
- 1&1 WebMail
- Virus scanner for 1 POP3 account

**\$9<sup>99</sup>**  
PER MONTH

**NO SETUP FEE!**

### BUSINESS PACKAGE

Sophisticated Business Solution

#### INCLUDES 3 DOMAINS

##### PACKAGE FEATURES

- 1,000 MB of Web space
- 5 FTP accounts
- 15,000 MB monthly transfer volume
- 1&1 Control Panel
- SSH Secure Shell Access
- SSI (Server side includes)
- SSL Secure Server
- Optional Dedicated SSL Certificate
- Hosted on 1&1 Linux platform

##### MARKETING TOOLS

- 1&1 Chat - 5 channels
- 1&1 WebStatistics
- In2site Live Dialogue
- 1&1 Newsletter Tool
- 1&1 WebElements

##### SITE-BUILDING TOOLS

- WebsiteCreator for 18 pages
- Full version software worth \$550
- FrontPage 2002 extensions
- CGI library & Free CGI programming
- Perl, PHP3 and PHP4
- 1&1 WebDatabase
- 1x MySQL database (100MB)
- Cron Jobs

##### DOMAIN NAMES

- Includes 3 domains (.com .net .org only)
- Handling of unlimited domain names
- DNS Management
- Point 100 external domains to 1&1
- 50 subdomains

##### E-MAIL

- 150 POP3 e-mail accounts
- Aliases, auto-responders, forwarding
- 1&1 WebMail
- Virus scanner for 3 POP3 accounts

**\$19<sup>99</sup>**  
PER MONTH

**NO SETUP FEE!**

### DEVELOPER PACKAGE

Delivering Superior Performance

#### INCLUDES 5 DOMAINS

##### PACKAGE FEATURES

- 2,000 MB of Web space
- 25 FTP accounts
- 30,000 MB monthly transfer volume
- 1&1 Control Panel
- SSH Secure Shell Access
- SSI (Server side includes)
- SSL Secure Server
- Includes Dedicated SSL Certificate
- Server priority
- Hosted on 1&1 Linux platform

##### MARKETING TOOLS

- 1&1 Chat - 10 channels
- 1&1 WebStatistics
- In2site Live Dialogue
- 1&1 Newsletter Tool
- 1&1 WebElements

##### SITE-BUILDING TOOLS

- WebsiteCreator for 25 pages
- Full version software worth \$550
- FrontPage 2002 extensions
- CGI library & Free CGI programming
- Perl, PHP3 and PHP4
- 1&1 WebDatabase
- 3x MySQL database (100MB)
- Cron Jobs
- Advanced Developer Tools

##### DOMAIN NAMES

- Includes 5 domains (.com .net .org only)
- Handling of unlimited domain names
- DNS Management
- Point 200 external domains to 1&1
- 200 subdomains

##### E-MAIL

- 300 POP3 e-mail accounts
- Aliases, auto-responders, forwarding
- 1&1 WebMail
- Virus scanner for 6 POP3 accounts

■ 90-DAY MONEY BACK GUARANTEE ■ 24/7 PHONE & E-MAIL SUPPORT



1.877.GO1AND1  
1AND1.COM

1&1

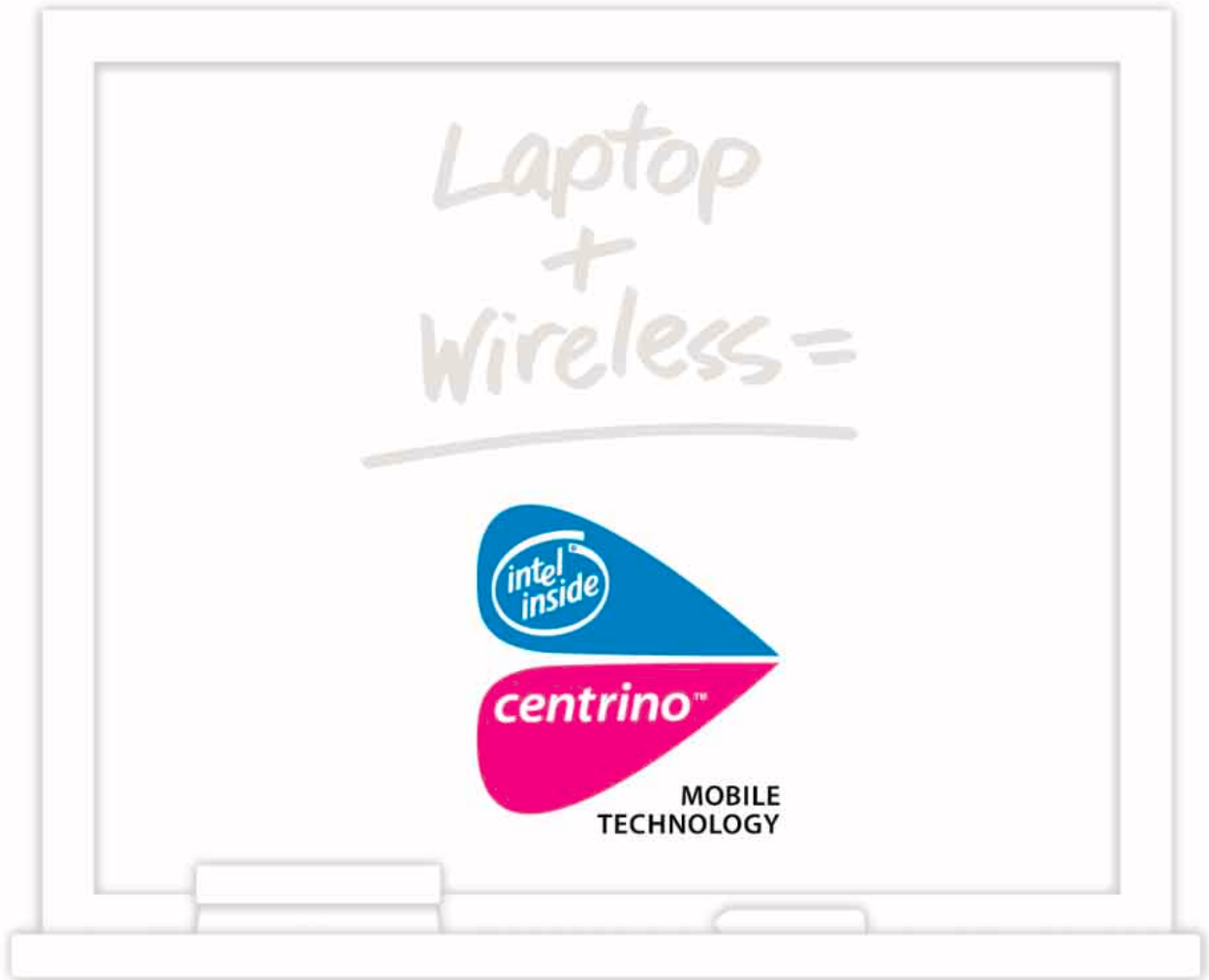

## The obvious answer for wireless computing.

No need to study for this one. If you're looking for a wireless laptop, make sure it has the right stuff. Look for the logo that says Intel® Centrino™ mobile technology is built in. Find out more at [intel.com/unwire](http://intel.com/unwire).

intel®

# EDITORS' CHOICES

AUGUST 3-16, 2004



In the market to buy? Here are our latest Editors' Choices in the leading technology categories—the products we've picked as the best from the hundreds that PC Magazine Labs has been testing. For links to the complete reviews, including dates of publication, visit [www.pcmag.com/editorschoice](http://www.pcmag.com/editorschoice).

## DESKTOP PCs & SERVERS

### GAMING DESKTOPS

- Falcon Northwest FragBox Pro
- Falcon Northwest Mach V

- Velocity Micro Vision FX

### MULTIMEDIA DESKTOPS

- Apple Power Mac G5 Dual 2 GHz
- Dell Dimension 8400

### MEDIA CENTER PC

- NEW** HP Media Center PC m1050y

### VALUE PC

- eMachines T2865

### HOME PC

- Sony VAIO PCV-W500GN1



Apple iBook

### STUDENT PC

- NEW** eMachines T3092

### SMALL-BUSINESS PC

- IBM ThinkCentre A50p

### CORPORATE PC

- IBM ThinkCentre S50

### ENTRY-LEVEL SERVER

- IBM eServer xSeries 306

### WORKGROUP SERVER

- Dell PowerEdge 1750

## PORTABLE PCs

### BUSINESS NOTEBOOKS

- Acer Travelmate 8000
- HP Compaq nc6000

### ULTRAPORTABLE

- IBM ThinkPad X40

### STUDENT NOTEBOOKS

- NEW** Apple iBook

- NEW** Velocity Micro NoteMagix B50 Campus Edition

### MULTIMEDIA NOTEBOOK

- Toshiba Satellite P25-S670



HP Media Center PC m1050y

### GAMING NOTEBOOK

- Dell Inspiron XPS

### VALUE NOTEBOOKS

- Averatec AV3225HS
- HP Compaq Presario R3000Z

### TABLET PCs

- Motion Computing M1400
- Toshiba Portégé M205-S809

## MOBILE DEVICES

### PDAs

- HP iPAQ Pocket PC h4350
- palmOne Zire 72

### PDA/PHONE COMBOS

- Handspring Treo 600
- Nokia 6600 Video Phone

### PHONE

- Motorola MPx200

### GPS DEVICE

- TomTom Bluetooth GPS Receiver

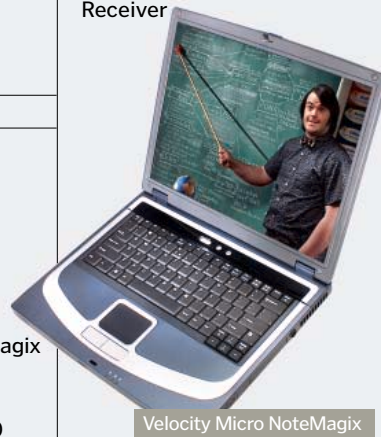

Velocity Micro NoteMagix

## HOME ENTERTAINMENT

### MEDIA HUBS

- Creative Sound Blaster Wireless (music)
- Prismiq MediaPlayer (multimedia)
- Turtle Beach AudioTron AT-100 (music)

### DIGITAL VIDEO RECORDER

- SnapStream Beyond TV 3 HDTV
- Sharp Aquos 37-inch LCD TV

## CAMERAS

### COMPACT CAMERAS

- Kodak EasyShare LS743
- Sony Cyber-shot DSC-T1

### MIDRANGE CAMERAS

- Casio Exilim Pro EX-P600
- Olympus C-5060 Wide Zoom

### SUPERZOOM CAMERA

- Olympus Camedia C-765 Ultra Zoom

### PROSUMER CAMERAS

- Konica Minolta DiMage A2
- Leica Digilux 2
- Olympus C-8080 Wide Zoom

### DIGITAL SLR CAMERA

- Nikon D70

### ENTRY-LEVEL DV CAMERA

- Sony DCR-HC40 MiniDV Handycam

## DIGITAL IMAGING

### FLATBED SCANNER

- Microtek ScanMaker 6100 Pro

### IMAGE EDITORS

- Adobe Photoshop CS (pro)
- Adobe Photoshop Elements 2.0 (consumer)

### PHOTO ALBUM SOFTWARE

- Adobe Photoshop Album 2.0

### PHOTO SHARING

- OurPictures

- Smugmug

### PHOTO-PRINTING SERVICE

- Shutterfly

## DIGITAL AUDIO & VIDEO

### ANALOG CAPTURE DEVICE

- HP DVD Movie Writer dc3000

### VIDEO EDITORS

- Adobe Premiere Pro (pro)
- Ulead VideoStudio 8 (consumer)

### CD/DVD-BURNING SUITE

- Roxio Easy Media Creator 7



iRiver H140

## DVD AUTHORIZING

- Sonic MyDVD 5.2 (consumer)
- Ulead DVD WorkShop 2 (pro)

## PORTABLE AUDIO

- Altec Lansing inMotion (iPod speakers)
- Apple iPod Mini
- Belkin Digital Camera Link

- NEW** Delphi XM Roady2

- NEW** iRiver H140

- iRiver iFP-390T

## SOUND CARD

- Creative Sound Blaster Audigy 2 ZS

## SPEAKERS

- Creative Gigaworks S750
- Klipsch ProMedia GMX D-5.1

## PC JUKEBOX

- Musicmatch Jukebox 8.2

## MUSIC STORE

- Napster 2.0

## WEBCAM

- Logitech QuickCam Pro

## PRINTERS

### PERSONAL PRINTERS

- Brother HL-5140 (laser)
- HP Deskjet 5150 (ink jet)
- Lexmark C510n (color laser)

### PERSONAL AIOs

- NEW** Brother MFC-3420 (ink jet)
- Brother MFC-8420 (laser)
- NEW** Canon MultiPass MP390 (ink jet)

### PHOTO PRINTERS

- Canon i9900 Photo Printer (pro)
- Epson Stylus Pro 4000 (pro)
- HP Photosmart 7960 (consumer)

### NETWORK PRINTERS

- HP LaserJet 9000dn (monochrome laser)

## EDITORS' CHOICES

AUGUST 3-16, 2004

- Xerox Phaser 4500DT (monochrome laser)
- Xerox Phaser 7750DN (color laser)

**DISPLAYS & STORAGE****BUSINESS DISPLAYS**

- IBM ThinkVision C220p
- NEC MultiSync LCD1960NXi
- Samsung SyncMaster 171N

**BUSINESS PROJECTOR**

- Sony VPL-CX85

**GAMING GRAPHICS CARD**

- ATI Radeon 9800 XT

**MAINSTREAM GRAPHICS CARD**

- PNY Verto GeForce 5700 FX Ultra

**DVD BURNERS**

- HP DVD Movie Writer dc3000
- Memorex True 8X External Dual Format Recorder

- Pioneer DVR-A07XL

- Sony DRU-700A

**EXTERNAL DRIVE**

- Western Digital Media Center

**REMOVABLE STORAGE**

- Iomega Rev 35

**PORTABLE PHOTO STORAGE**

- Micro Solutions RoadStor

**PRODUCTIVITY SOFTWARE****OFFICE SUITE**

- Microsoft Office 2003

**OCR**

- ScanSoft OmniPage Pro 14 Office

**PDF CREATION**

- Adobe Acrobat 6.0
- FinePrint pdfFactory PRO 1.57
- Jaws PDF Creator 3.0

**DOCUMENT MANAGEMENT**

- ScanSoft PaperPort Pro 9 Office

**DESKTOP PUBLISHING**

- Adobe InDesign CS

**FINANCE & ACCOUNTING**

- Microsoft Money 2004 Premium
- QuickBooks Premier 2004
- Quicken 2004 Premier

**WEB SITE CREATION**

- NeoVerve StoreSense

**WEB RESEARCH**

- Onfolio Professional

**MEDIA CREATION SUITE**

- Roxio Easy Media Creator 7

**E-MAIL CLIENT**

- Microsoft Outlook 2003

**VIDEOCONFERENCING**

- SightSpeed Video Messenger
- VidiTel

**DATABASE**

- FileMaker Pro 7

**BLOG/WIKI TOOLS**

- EditMe
- Socialtext Workplace 1.0
- TypePad

**UTILITIES****ANTIVIRUS**

- Norton AntiVirus 2004

**FIREWALLS**

- Norton Personal Firewall 2004
- ZoneAlarm Pro 5

**SECURITY SUITES**

- Norton Internet Security 2004
- ZoneAlarm Security Suite 5

**ANTISPYWARE**

- SpySweeper 2.2

**ANTISPAM**

- NEW** Cloudmark SpamNet 2.5

- NEW** MailFrontier Desktop 4.0

- Qurb

**POP-UP BLOCKER**

- PopUp Cop

**INSTANT MESSAGING**

- MSN Messenger 6.1

**FILTERING/MONITORING**

- Cybersitter 9.0
- Spector Pro 5.0

- The Children's Internet



Vtech V.Smile Learning System, Smartbridge Library

**FILE****COMPRESSION**

- PKZip 8.0 for Windows
- StuffIt Deluxe 8.0

**BACKUP**

- Retrospect Pro 6.5
- iBackup

**ROLLBACK**

- Norton GoBack 3.0

**DISK IMAGING**

- Acronis True Image 7.0

**PARTITIONING**

- PartitionMagic 8.01

**DEFRAGGERS**

- Diskkeeper 8.0 Pro

- PerfectDisk 6.0

**REMOTE ACCESS**

- LapLink Everywhere 2.0

**FILE MANAGER**

- Novatix ExplorerPlus 6.1

**MIGRATION**

- Alohobob PC Relocator Ultra Control

- Desktop DNA Pro 4.7

**TOOLBARS**

- Dogpile

- Google Toolbar

**DESKTOP CUSTOMIZATION**

- Object Desktop 2004

**DOWNLOAD MANAGER**

- DownloadStudio 1.0

**SCREEN CAPTURE**

- SnagIt 7.0.3

**FILE VIEWER**

- IrfanView 3.85

**VIRTUAL PC**

- VMware Workstation 4.5

**PASSWORD MANAGER**

- AccountLogon 2.5

**ENTERPRISE SOFTWARE & DEVELOPMENT****NETWORK ANTIVIRUS**

- Trend Micro Enterprise Protection Strategy

**ENTERPRISE ANTISPAM**

- BrightMail Anti-Spam 5.1
- Postini Perimeter Manager

**E-MAIL SERVER PLATFORM**

- IBM Lotus Notes and Domino 6.5

**WIRELESS PLATFORM**

- GoodLink 3.0

**WEB FILTERING**

- Websense Enterprise 5.1

**CRM**

- salesforce.com Enterprise Edition

**DATABASE**

- Oracle 9i Database

**WEB CONFERENCING**

- WebEx Meeting Center

**ENTERPRISE DEVELOPMENT**

- Borland JBuilder 9

- IBM WebSphere Studio Device Developer 5.6

- (mobile)

- SQL Anywhere Studio 9

- (mobile)

**WEB SITE DEVELOPMENT**

- Macromedia Contribute
- Macromedia Studio MX 2004

**WEB SITE ANALYSIS**

- WebSideStory HBX

**VULNERABILITY SCANNER**

- Retina Network Security Scanner

**NETWORKING****SERVER OS**

- Microsoft Windows Server 2003 Enterprise Edition

**WIRELESS INFRASTRUCTURE**

- NEW** Hawking HWPS12UG (print server)

- Linksys Wireless-G

- WRT54GS (802.11g)

- Netgear ProSafe-FWAG114 (802.11a/g)

**SECURITY APPLIANCE**

- ServGate EdgeForce

**REMOTE-ACCESS APPLIANCE**

- Neoteris Access 1000

**GAMES & EDUCATIONAL SOFTWARE****SIMULATION**

- Microsoft Flight Simulator 2004

**ACTION/COMBAT**

- Battlefield Vietnam

- Far Cry

- Halo: Combat Evolved

- Orbz 2

- Savage: The Battle for Newerth

**SPORTS**

- Madden NFL 2004

**REAL-TIME STRATEGY**

- NEW** Rise of Nations: Thrones and Patriots

**VIRTUAL WORLD**

- Second Life

**ONLINE**

- EverQuest: Evolution

**EDUCATION**

- eMedia Beginner Guitar Method 3.0

- Math Mission: The Race to Spectacle City Arcade, The Amazing Arcade Adventure

- NEW** Vtech V.Smile Learning System, Smartbridge Library

- Zoombinis Island Odyssey

**MOBILE GAME**

- Bejeweled

**REFERENCE**

- NEW** Microsoft Encarta

- Rerence Library 2005

- Visual Thesaurus

**verizon**wireless  
We never stop working for you.®



Makes laptop connections wireless

Check email or access corporate intranet

Easy to set up and install



Verizon Wireless PC 5220 Card

## **VZACCESS.**

**Even if the train's late, your work gets out on schedule.**

Trains and planes may disappoint you, but you can always count on Verizon Wireless. That's because we have the latest data solutions to keep your employees productive even when they're on the road. With **VZAccess**™ from **VZOffice**™ and a wireless PC card in their laptops, your employees will enjoy convenient wireless access to the Internet, corporate intranet, emails, databases, files and applications – all without a frantic search for a landline wire, jack or ISP. So keep productivity on schedule across the U.S. with Verizon Wireless. Because for all your company's wireless needs, we mean business.

**Contact our business representatives at 1.800.VZW.4BIZ or log on to [verizonwireless.com](http://verizonwireless.com).**

Coverage & service not available in all areas. Must be within NationalAccess rate and coverage area. Check with your IT department for corporate Internet access requirements.  
©2004 Verizon Wireless

Small&Medium Business

# Reliable solutions built around your business.

No matter what business you've built.



**For IT solutions you can count on, you can count on Dell.** From PowerEdge™ servers featuring Intel® Xeon™ processors to network support products like PowerVault™ storage and PowerConnect™ switches, Dell offers flexible, high-performance industry-standard technologies and software solutions that are just right for your particular business needs. And we'll help you every step along the way. Whether it's planning and design, testing and validation, systems management, or our award-winning 24x7 service and support, Dell will help you create a customized IT infrastructure that's easy to choose, deploy and manage. So make life easy on yourself and get a big advantage over your competition – with a reliable IT solution from Dell.



**PC Magazine 2003 Best of the Year**

PowerEdge 1750  
– January 20, 2004

Call: M-F 7a-8p Sat 8a-5p, CT

Pricing, specifications, availability and terms of offer may change without notice. Taxes, fees and shipping charges extra, and vary and not subject to discounts. U.S. Dell Small Business new purchases only. Dell cannot be held responsible for pricing or other errors, and reserves the right to cancel orders arising from such errors. \*Service may be provided by third party. Technician will be dispatched following phone-based troubleshooting. Subject to parts availability, geographical restrictions and terms of service contract. Service timing dependent upon time of day call placed to Dell. U.S. only. \*\*Monthly payment based on 48-month Fair Market Value ("FMV") QuickLease and does not include taxes, fees and shipping charges. Your monthly payment may vary, depending on your creditworthiness. QuickLease arranged by Dell Financial Services L.P. ("DFS"), an independent entity, to qualified Small Business customers. Minimum transaction size of \$500 required. At the end of the FMV QuickLease, you can purchase the equipment for the then FMV, renew the lease or return the equipment to DFS. Please contact your DFS representative for further details. All terms subject to credit approval and availability, and are subject to change without notice. †This device has not been approved by the Federal Communications Commission for use in a residential environment.



## File&Print Servers starting at \$499

Affordable servers that make  
managing your network easy.

### POWEREDGE™ 400SC SERVER

#### Small Business Value Server

- Intel® Pentium® 4 Processor at 2.80GHz
- Upgradable to Intel® Pentium® 4 Processor at 3.20GHz with 800MHz Front Side Bus
- 256MB 400MHz ECC DDR SDRAM
- Upgradable to 4GB DDR SDRAM
- 40GB (7200 RPM) IDE Hard Drive
- Upgradable to 240GB of Internal Hard Drive Storage
- RAID 1 Optional
- Embedded Intel® PRO Gigabit® NIC
- 1-Yr Next Business Day On-Site Service<sup>1</sup>
- Small Business Pricing

**\$799** Lease as low as **\$22/mo.**, (48 pmts.<sup>2</sup>)  
E-VALUE Code: 01055-S2070g

### NEW POWEREDGE™ 700 SERVER

#### Value Tower Server

- Intel® Pentium® 4 Processor at 2.80GHz
- Upgradable to Intel® Pentium® 4 Processor at 3.40GHz with 800MHz Front Side Bus
- 512MB ECC DDR SDRAM (Up to 4GB)
- 80GB (7200 RPM) SATA Hard Drive
- Upgradable to 1TB of Internal Hard Drive Storage
- Embedded Intel® PRO Gigabit® NIC
- Five PCI Slots (3-64/66MHz, 2-32/33MHz)
- Optional DRACIII/XT Adapter for Remote Management
- 3-Yr Next Business Day On-Site Service<sup>1</sup>
- Small Business Pricing

**\$1029** Lease as low as **\$28/mo.**, (48 pmts.<sup>2</sup>)  
E-VALUE Code: 01055-S20710g

## Database&Web Hosting Servers starting at \$1699

Flexible server solutions to  
manage diverse networks.

### POWEREDGE™ 2600 TOWER SERVER<sup>2†</sup>

#### Multi-Use Tower Server

- Intel® Xeon™ Processor at 2.40GHz
- Dual Intel® Xeon™ Processor Capable (Up to 3.20GHz)
- 512MB 266MHz ECC DDR SDRAM
- Upgradable to 12GB of ECC DDR SDRAM
- Dual 36GB (10K RPM) Ultra320 SCSI Hot-Swap Hard Drives
- RAID 1 Included
- Active ID Bezel for Monitoring System Health
- 3-Yr Next Business Day On-Site Service<sup>1</sup>
- Small Business Pricing

**\$2349** Lease as low as **\$63/mo.**, (48 pmts.<sup>2</sup>)  
E-VALUE Code: 01055-S20723g

### POWEREDGE™ 1750 RACK SERVER<sup>2†</sup>

#### Feature-Rich 1U Rack Server

- Intel® Xeon™ Processor at 2.80GHz
- Dual Intel® Xeon™ Processor Capable (Up to 3.20GHz)
- 1GB 266MHz ECC DDR SDRAM
- Upgradable to 8GB of ECC DDR SDRAM
- 3x36GB (10K RPM) Ultra320 SCSI Hot-Swap Hard Drives
- RAID 5 Included
- Active ID Front Bezel for Monitoring System Health
- 3-Yr Next Business Day On-Site Service<sup>1</sup>
- Small Business Pricing

**\$2769** Lease as low as **\$74/mo.**, (48 pmts.<sup>2</sup>)  
E-VALUE Code: 01055-S20727g

## 4-Way Servers

Build a powerful, protected network.

### POWEREDGE™ 6650 RACK SERVER

#### High-Speed Mission Critical Rack Server

- Intel® Xeon™ Processor at 2.0GHz
- Quad Intel® Xeon™ Processor Capable (Up to 3.0GHz)
- 1GB ECC DDR SDRAM
- Up to 32GB ECC DDR SDRAM
- Up to 730GB Maximum Internal SCSI Hard Drive Storage
- Embedded Ultra SCSI Adaptec® (160MB/s) Controller
- Standard Hot-Swap Hard Drives, Hot-Swap Redundant Fans and Hot-Swap Redundant Power Supplies
- 7 Hot-Plug PCI-X Slots
- 3-Yr Next Business Day On-Site Service<sup>1</sup>

starting at  
**\$4999** Lease as low as **\$133/mo.**, (48 pmts.<sup>2</sup>)

## Network Storage Options

### NEW POWERVAULT™ 745N NAS

#### Optimized File Storage Across the LAN

- Intel® Celeron® Processor at 2.40GHz
- Microsoft® Windows® Storage Server 2003
- 512MB DDR SDRAM (Up to 4GB)
- 4x40GB SATA Hard Drives (Up to 4TB)
- Software or Hardware RAID Available for Data Security

starting at  
**\$1799** Lease as low as **\$48/mo.**, (48 pmts.<sup>2</sup>)

### DELL/EMC

Visit [www.dell.com/storage4mybiz](http://www.dell.com/storage4mybiz) if you have more than 300GB of storage, for low prices on Dell/EMC storage arrays.

## Services

### Purchase

Dell offers a wide range of reliable, award-winning technology, all delivered from a single point of contact – and our expert sales associates are there to help you find the technology that's right for your business.

### Installation – Starting at \$279

Once you've selected the right technology, Dell can help you get it up and running quickly and cost-effectively with our custom on-site installation and configuration services.

### Training&Certification – Starting at \$100/person

After installation, Dell can help turn your employees or IT staff into experts on your new technology through a variety of training and certification courses – helping increase your business' long-term productivity.

### Service&Support

The support doesn't end at the sale. Dell's award-winning service and support offerings help ensure that your new network remains up and running – with Web, phone or on-site service<sup>3</sup> and support.

## Network Switches starting at \$69

### POWERCONNECT™ 3324 SWITCH<sup>2†</sup>

#### High-Performance Workgroup Switch

- 24 Fast Ethernet Ports plus 2 Gigabit Uplinks (2 Copper and 2 SFP Transceiver Combo Slots for Fiber)
- Stacking Functionality of Up to 192 Ports
- Advanced Network Management and Security Features
- Industry Standard CLI and Easy-to-Use Web Interface
- 3-Yr Next Business Day Advanced Exchange Service<sup>2</sup> Standard

**\$499** Lease as low as **\$14/mo.**, (48 pmts.<sup>2</sup>)  
E-VALUE Code: 01055-S10704

Solutions that fit. Easy as 

Click [www.dell.com/bizsolutions](http://www.dell.com/bizsolutions) Call 1-877-337-3355

toll free

This device is not, and may not be, offered for sale or lease, or sold or leased for use in a residential environment until the approval of the FCC has been obtained. <sup>1</sup>This term does not constitute an actual operating speed of 1GB/sec. For high-speed transmission, connection to a Gigabit Ethernet server and network infrastructure is required. <sup>2</sup>Technician, replacement part or unit (depending on service contract) will be dispatched, if necessary, following phone-based troubleshooting in advance of receipt of returned defective unit. Service may be provided by third-party provider. Subject to parts availability, geographical restrictions and terms of service contract. Service timing dependent upon time of day call placed to Dell. Defective unit must be returned. Replacements may be refurbished. U.S. only. Dell, the stylized E logo, E-Value, PowerEdge, PowerConnect and PowerVault are trademarks of Dell Inc. Intel, Intel Inside, the Intel Inside logo, Intel Xeon, the Intel Xeon logo, Pentium and Celeron are trademarks or registered trademarks of Intel Corporation or its subsidiaries in the United States and other countries. ©2004 Dell Inc. All rights reserved.

  
Online For  
Latest Prices  
and Weekly  
Promotions

# FIRST

HANDS-ON TESTING OF NEW PRODUCTS • [www.pcmag.com/firstlooks](http://www.pcmag.com/firstlooks)

- 34 Apple iPod 40GB
- 34 Creative Nomad Zen Xtra 60GB
- 35 iRiver H140
- 35 Rio Karma
- 35 Frontier Labs L1

- 35 Philips Recording Audio Jukebox HDD120
- 35 PoGo! RipDrive 30GB
- 36 HP Media Center PC m1050y
- 36 Microtel SYSWM8001



- 36 Cyberpower Gamer Ultra 9900 Pro
- 36 Overdrive PC a.Torque FX
- 36 HP Pavilion a550e
- 37 Paint Shop Photo Album 5
- 37 Nelson Email Organizer Pro 3.0

## Antispam Tools Keep Up

THE MAGAZINE  
WORLD'S LARGEST  
COMPUTER-TESTING  
FACILITY



BY NEIL J. RUBENKING

The deluge of spam just keeps increasing, and spammers are getting sneakier every day, so antispam products have to get tougher to stay ahead of the game. We tested the latest versions of five spam blockers to see if they could hold back the flood. • We configured each product according to the vendor's advice for minimizing the amount of legitimate mail misfiled in the spam folder (false positives) while still keeping the most spam out of our in-box (false negatives).

Where there was a choice, we tested with Microsoft Outlook or Outlook Express, based on the vendor's recommendation.

Four of the five products we reviewed use filtering techniques—analyzing message content and headers—to identify spam. To test those, we diverted a stream of spam-infested, real-world messages to multiple e-mail accounts, each protected by one of the products. For comparison, we ran the same e-mail stream through Outlook's own spam filter and through Cloudmark SpamNet and Aladdin's Spam Catcher, both of which did well in our last roundup ("Can E-Mail Survive?," February 17, 2004; [www.pcmag.com/spam](http://www.pcmag.com/spam)).

For ten days, we manually trained the products, correcting any legitimate mail that was misfiled as spam or vice versa. Then we cleared the inboxes and configured the programs to use only filtering to identify spam—not whitelists, blacklists, or challenge/re-

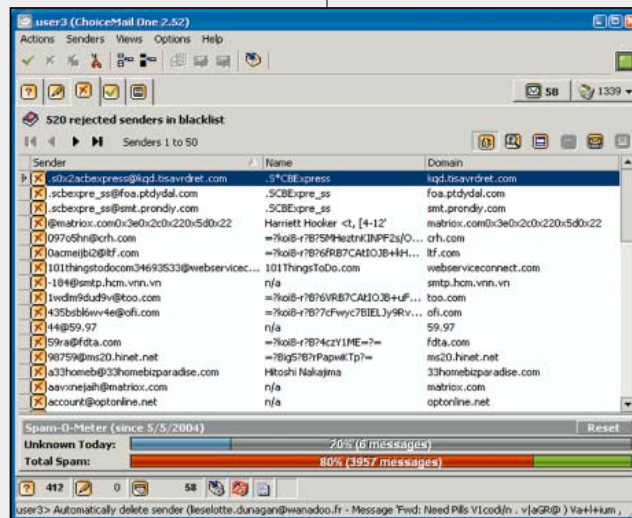

**THE DEADWOOD ADDS UP QUICKLY**, as you can see when you check the list of rejected senders in ChoiceMail One.

sponse systems. We let them run for ten more days and then exported each product's mailbox using askSam 6. We identified the messages that were received by all of the products and discarded the rest. Next, we manually identified the remaining messages as undeni-

ably spam or undeniably valid, deleting all others. The results, shown in the accompanying chart, reflect only the product's ability to filter spam. When whitelisting, blacklisting, and challenge/response (if available) are enabled, accuracy will naturally improve.

### ChoiceMail One 2.52

The exception to the test methodology described above was for ChoiceMail One 2.52, which uses whitelists and challenge/response almost exclusively. It does have some very specific filters to weed out blatant spam, but it relies more heavily on the choices you make as to what to block and what to allow.

Contacts in your address book are automatically whitelisted, as are any to whom you send mail. Unknown senders must click on a link in a challenge message and verify their identity. Messages that are positively identified as spam get sent to the Junk Box without a challenge. For a product that doesn't rely on filtering as its main weapon, this identification is surprisingly effective: It correctly identified over three-quarters of our spam messages. Users can also proactively accept or reject senders whose response is pending.

ChoiceMail runs separately from your e-mail client, which must have automatic mail checking turned off. You can check mail after ChoiceMail finishes scanning, though its processing is noticeably slow. On an informal test, Outlook Express downloaded 450 messages in less than 2 minutes, while ChoiceMail spent over 15 minutes on that same batch of mail. This may be a bit frustrating if you're in a hurry to view a weekend's accumulation of mail.

The Junk Box lists rejected mail, including the reason for rejection, with a safe preview. Legitimate e-mail almost never

# LOOKS

WHAT THE RATINGS MEAN: ●●●●● EXCELLENT | ●●●●○ VERY GOOD | ●●●○○ GOOD | ●●○○○ FAIR | ●○○○○ POOR

- 38 Gmail
- 38 PentaSuite 71
- 39 JVC MP-XV841 Mini Note PC
- 39 Delphi XM Roady2
- 42 Tapwave Zodiac 1

- 42 Nokia N-Gage QD
- 43 Kyocera Finecam M410R
- 43 Olympus Camedia C-770 Ultra Zoom
- 43 Concord Eye-Q 5345z
- 43 Kodak EasyShare LS75

- 43 Konica Minolta DiMage G600
- 44 NEC MultiSync LCD2060NX
- 44 Envision EN9250
- 44 ViewSonic VP201s
- 44 Dell 3300MP

- 44 HP f2304 23-inch High Definition LCD Monitor
- 46 Gordano Messaging Suite
- 46 Scalix 9.0
- RED type denotes Editors' Choice.

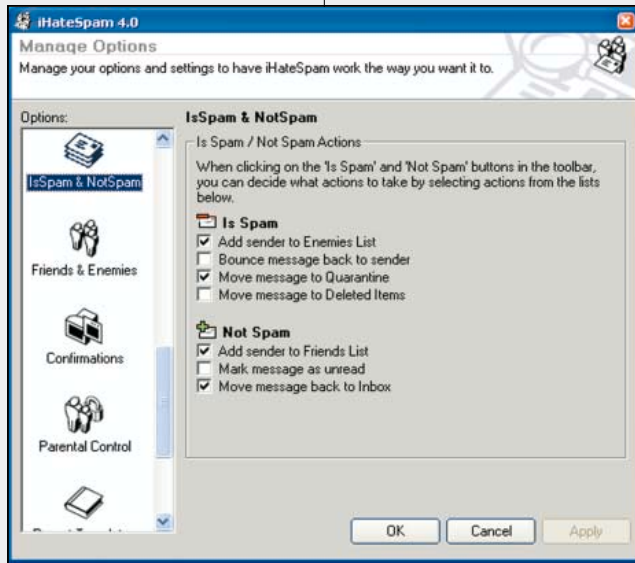

**THE TRAINING PANE** in iHateSpam lets you easily add senders to your blacklist or whitelist, bounce messages, and more.

## iHateSpam 4.0.426

Sunbelt Software's iHateSpam 4.0.426 analyzes incoming e-mail in a variety of ways. Simple "friends" and "enemies" lists identify senders to be allowed or blocked. iHateSpam can also block specific country codes or languages. And of course, it analyzes message content and headers: Its filtering engine can learn from manually marked messages, and its Spam Learning Network can block messages that other users have marked as spam.

Unfortunately, a glitch in the learning module caused the filtering to get progressively worse instead of better. Almost half of the good e-mail was flagged as spam. Sunbelt supplied an update and we re-scanned all the messages, but any benefit derived from the ten days of training was lost. In practice, you can expect iHateSpam's accuracy to improve.

You can scan an existing folder of messages using iHateSpam, a feature that made it possible for us to retest the product after the glitch mentioned above. The application also lets you bounce spam or report it to authorities, though these tactics probably won't affect major spammers.

One unusual feature is the Safe Unsubscribe list, which identifies mailing lists or other mass e-mails verified by Sunbelt as having functional unsubscribe options. If you mark such a message as spam or flag the sender as an enemy, iHateSpam will point out that you can simply unsubscribe instead, without worrying that by doing so

you're inviting added spam.

iHateSpam integrates best with Microsoft Outlook, where it supports IMAP and Exchange in addition to POP3. You can also filter POP3 mail in Outlook Express, and (new in this version) Eudora and IncrediMail, but not all features are available. In addition, Version 4.04.26 can filter Web-based Hotmail accounts for Internet Explorer 6 users who are running Windows XP.

iHateSpam is a user-friendly spam-filtering solution for Outlook users. On our tests, however, its untrained accuracy was no better than Outlook's built-in filter. With training and fine-tuning it will do better, and at \$19.95, it's a bargain.

### iHateSpam 4.0.426

\$19.95 direct. Sunbelt Software Inc., [www.sunbelt-software.com](http://www.sunbelt-software.com). ●●●○○

### SPAM-FILTERING TESTS

- Legitimate mail misfiled in the spam folder (false-positive percentage)
- Spam misfiled in the in-box (false-negative percentage)
- Bold type denotes first place.

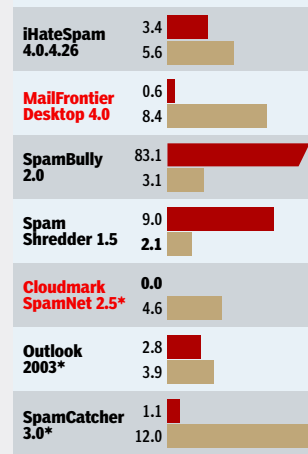

◀ BETTER  
\* Reported for comparison. Since ChoiceMail One 2.52 is not primarily a filtering product, we did not test it with our standard tests. RED denotes Editors' Choice.

winds up there, but if it does, you can approve the sender with a single click. You'll want to review and purge the Junk Box frequently, since access is markedly slow when thousands of messages pile up.

ChoiceMail's user interface is somewhat quirky, and the app's vast number of configuration options are scattered in several distinct dialogs. Instead of a context-sensitive help system, users get a PDF document. Fortunately, the average user won't need to configure ChoiceMail very often.

You can use ChoiceMail with any POP3 client. It supports IMAP accounts as long as you're using Outlook, Outlook Express, or Eudora. Microsoft Exchange users will need to install the server-side ChoiceMail Enterprise product. It can also filter Web-based mail from AOL, Hotmail, MSN, and

Yahoo!—and as a bonus, it converts the mail to POP3.

Challenge/response systems can block important e-mails, such as confirmation of merchandise orders sent by a server, not a human. So ChoiceMail now offers each user up to five virtual e-mail addresses: Messages sent to these addresses are accepted automatically. If an account starts getting spam, just delete it and create a new one.

Though ChoiceMail relies primarily on its whitelists, blacklists, and challenge/response system, bonus features like disposable e-mail addresses and filtering of blatant spam enhance its usability. It supports a wide variety of e-mail clients and services. We did find, however, that it slows downloading of mail considerably.

**ChoiceMail One 2.52**  
\$39.95 direct. DigiPortal Software Inc., [www.digiportal.com](http://www.digiportal.com). ●●●○○

**MailFrontier Desktop 4.0**

MailFrontier Desktop (formerly Matador) pioneered the combination of challenge/response spam blocking with rule-based filtering, and it does a fine job of filtering out spam based on content. It also offers the unique ability to detect and report phishing scams separately. It can process IMAP, POP3, and Hotmail accounts with Outlook Express, or POP3 and Exchange accounts with Microsoft Outlook.

MailFrontier Desktop requires little configuration. Simple slider controls adjust the program's filtering in several ways: You can control how much weight is given to collaborative filtering (based on other users marking a specific message as junk) and raise or lower the filter's overall aggressiveness. You can also fine-tune the filter to increase or decrease its emphasis on specific areas such as sexual content or gambling.

If you use the challenge/response feature, you can choose either a photo-based challenge that requires the respondent to count puppies or kittens or a more businesslike verification request. Either can be personalized with your name and a note. In addition, you can choose whether to send a challenge to every unknown sender or just to those whose messages appear to be junk mail.

In our testing, MailFrontier Desktop misfiled just one valid e-mail message in its Junk Mail folder (a false positive). It did allow a bit more spam into our in-box than most (false negatives), but we intentionally configured the products to minimize false positives, possibly at the expense of letting more spam through. Its clear reporting module revealed that about 40

percent of our junk mail was blocked based on collaborative filtering and that the remaining 60 percent was blocked based on message content.

As long as you use Outlook or Outlook Express, MailFrontier Desktop is a fine choice for spam protection. Its accuracy in distinguishing good mail from spam is excellent, and it offers the additional protection of a well-developed challenge/response system.

**MailFrontier Desktop 4.0**

\$29.95 direct. MailFrontier Inc., [www.mailfrontier.com](http://www.mailfrontier.com). ●●●●○

**SpamBully 2.0**

SpamBully 2.0 contains an option to "punish" spammers by repeatedly hitting the URLs contained in their messages—potentially running up their Web site maintenance bills—which may be satisfying to some. This version adds quite a few new features, such as blocking mail based on country or character set, allowing or blocking mail based on user-defined



**THE CHALLENGE** feature in MailFrontier will have your senders counting cats, or you can choose a more businesslike verification.

word lists, optional Bayesian analysis of Web pages linked to by messages, support for blocking domains listed on RBLs (Realtime Blackhole Lists), and a learning mode for fine-tuning

the product's filtering.

The program's Outlook-only challenge/response option might go unnoticed, as it is turned off by default. Unknown senders get a simple e-mail challenge with a code word in a bitmap image; they need only respond with the code word in the subject or body. When the response is received, SpamBully moves the challenged message to your in-box.

During the training phase, we found a surprisingly large number of legitimate e-mails from individuals routed to the Spam folder, even though we had configured the product according to Axaware's recommendations to minimize false positives. We dutifully trained the filter by marking these with the Not Spam button. The company advised us that to get better results we could analyze the messages and add words and phrases to the Allow/Block lists. Since we were testing the filtering ability of the product itself, we did not do this.

The final results were dismal, to say the least: More than 80 percent of the good e-mails went into the Spam folder. We experimented with resetting the Bayesian learning filter and even disabling it, but the results were even more out of line. The company indicated that using an active whitelist and training on thousands of manually identified good e-mails and spam messages would provide better results.

Although SpamBully 2.0 has added some nice features, we can't recommend a product whose spam-filtering engine requires such a high degree of training—not when others perform dramatically better out of the box.

**SpamBully 2.0**

\$29.95 direct. Axaware LLC, [www.spambully.com](http://www.spambully.com). ●●○○○

**Spam Shredder 1.5**

Webroot's Spam Shredder installs as a local POP3 server, filtering the mail from your actual POP3 server. It doesn't matter which e-mail client you use, as long as your account is POP3-based. As a side benefit, it can delete blacklisted e-mail right on the server, without ever downloading a copy locally. The deleted message is replaced by a dummy to avoid a mismatch in the expected message count.

We found that Spam Shredder's processing significantly slowed e-mail downloads. Where Outlook Express downloaded 450 messages in under 2 minutes and Outlook took about 3 minutes for the same batch, Spam Shredder took over 25 minutes. Blocked messages are held in an internal quarantine queue, which you must review frequently to keep manageable. When you rescue good e-mail from quarantine, the filtering engine adjusts to improve future accuracy—and you can also whitelist the sender.

The preview window for reviewing quarantined messages is tiny, lacks a scroll bar, and displays all message headers above the message text, which makes it hard to use. Also, when you delete or release a message, the list scrolls back to the top, so it's hard to review systematically. The Delivery Log lists messages that were released to the client, giving the user an option to blacklist senders of any messages that were released in error. But no preview is available for delivered messages, so it may be necessary to match up the subject or sender with spam messages found in the e-mail client.

Spam Shredder let very little spam through, but it flagged 9 percent of our undeniably good mail as spam. And, as noted, rescuing misfiled good mail is an awkward process. ☰

**Spam Shredder 1.5**

\$29.95 direct. Webroot Software Inc., [www.webroot.com](http://www.webroot.com). ●●○○○

# LG FLATRON LCDs. Available in LG, XLG and XXLG.



©2004 LG Electronics U.S.A., Inc.

## Because one size does not fit all.

With screen sizes from 15" to 30", offering features such as DVI and HD inputs or TV function, there's a perfect LG fit for every home or office. LG LCD monitors offer exceptional quality, innovative features and are all backed by an outstanding 3-year replacement warranty.

The view is better with LG.

Available at:



BestBuy.com®

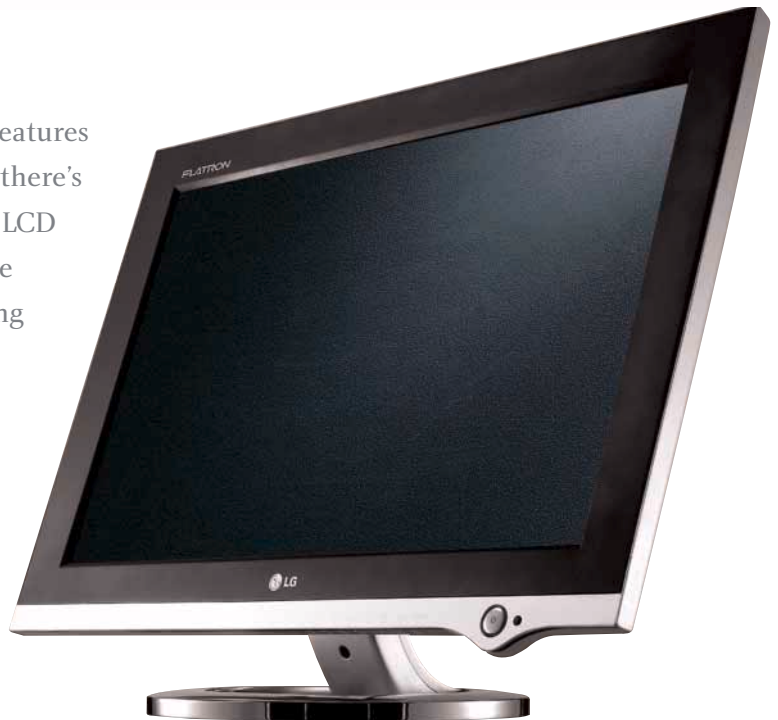

L2320A - 23" Wide-Screen HD/WUXGA LCD Monitor

[www.LGUSA.com](http://www.LGUSA.com)

## FLATRON®



# New Music Players Gun for the iPod

BY BILL MACHRONE

Apple's iPod has fairly well dominated the music player market for the past two years. But that's not for lack of trying on the part of competitors, and now that they've had a while to play catch-up, we're seeing some entries that give the iPod a run for its money.

So we gathered six of the latest entries to see how they stack up. Our conclusion: While the iPod still delivers the most intuitive, elegant user interface, the best value in the 20GB-plus class is the iRiver H140. (The iPod Mini is still our Editors' Choice if you want a smaller player and can do with less capacity.)

How all these will compare with the announced but as yet unavailable Sony Walkman NW-HD1 is yet to be seen. Sony's entry, set to be released here in September, will hold 13,000 songs on its 20GB drive (thanks to Sony's compression technology). But if you're in the market to buy now, the reviews here should help narrow your choices.

## Apple iPod 40GB

The Apple iPod is the player against which all other players are compared—and rightly so. The design was startlingly original when it was introduced, and it still feels fresh. The 40GB version we tested is slightly larger (6.1 ounces, 4.1 by 2.4 by 0.8 inches, HWD) than the 15GB and 20GB versions, but it's still among the smallest players in the high-end category. But be warned: You do pay a premium for the iPod's reputation, style, and interface, compared with other players.

The iPod's screen is bright, and thanks to the retroreflective background, it's easy to read in most any light. The touch-sensitive controls work smoothly and



logically. In conjunction with the company's iTunes jukebox app, the player organizes your music by artist, album, title genre, and even composer, and all are easily navigable. This model comes standard with a wired remote, which is handy when you're on the go and want to change the volume or advance to the next song.

The iPod offers a wide range of equalizer (EQ) presets but no user-adjustable EQ settings. The measured frequency response into our spectrum analyzer was excellent. The iPod sounded very good all the time but was definitely best playing through our 64-ohm Sennheiser HD280 Pro headphones.

The iPod has other features, including a large-format clock and some PIM functions, such as an address list, calendar, and text file display. It also has some games. But it lacks the voice recorder and FM radio tuner others now offer, unless you add aftermarket devices. And that said, a mini-industry has sprouted to supply iPod users with useful (and some frivolous) accessories, which give it an extensibility others can't match.

Do note that the iPod's battery (which gave us just over

**THE IPOD'S DESIGN** is wearing well, but others beat it on value.

7 hours of runtime on a charge) is not meant to be user-replaceable. So when it stops holding a charge (figure two years' worth of typical use), you'll need to send it to Apple or a third party for a replacement (at a cost to you of \$50 to \$100).

The iPod is still the cream of the crop when it comes to the interface. But you'd have to value style and function highly to pay the price, given the new entrants in the field.

## Apple iPod 40GB

\$460 street. Apple Computer Inc., [www.apple.com](http://www.apple.com). ●●●●○

## Creative Nomad Zen Xtra 60GB

With an expanse of sheet metal below the screen, the Creative Nomad Zen Xtra looks like it might be missing something when compared with other players, but it's not. An easily replaceable battery (that lasted a laudable 10 hours on our tests) lurks within, and all the controls are along the sides of the player. We tested the 60GB player, and try as we might, we simply didn't have enough music to fill it up.

The Zen Xtra has a broad, mostly flat frequency response,



with just a bit of weakness in the low end, but you'd never hear that if you listen through anything other than a stereo with a real subwoofer or studio-quality headphones. In addition to a full complement of EQ presets and custom EQ settings, the Zen Xtra has EAX, which adds echo/room effects, spatialization, and slowdown or speedup of music.

The EQs are mostly unnecessary, though, because the Zen Xtra sounds fine with no additional EQ, and several of the EQ settings dull the sound. In fact, the room size/echo and spatialization effects sound terrible; they're not even amusing. The speed control, however, is useful. You can slow down your music without changing its pitch if you want to learn a riff, and you can greatly speed up voice material, such as audio books, without impairing the sense of it. Evidently, we can listen considerably faster than we can speak.

The belt holster is well designed, and it needs to be: At 7.9 ounces (4.4 by 3.0 by 0.9 inches, HWD), you'll have something substantial on your hip. The supplied ear buds are deficient in high frequencies and sound somewhat fuzzy and indistinct compared with better ones.

With more storage than most portable computers, the Zen Xtra is a formidable ally in conquering your digital music collection. At about \$360, the Zen Xtra 60GB is a serious purchase. But if you want the Zen Xtra's features at a lower price, consider the 30GB version (\$220 street), which is probably enough storage for most people.

## Creative Nomad Zen Xtra 60GB

\$360 street. Creative Labs Inc., [us.creative.com](http://us.creative.com). ●●●●○

**THE ZEN XTRA'S** 60GB capacity should more than suffice.

**iRiver H140**

With superlative sound and a multi-features, the 40GB iRiver H140 is the new digital audio player to beat. It goes far beyond the typical player, offering voice and audio recording as well as FM radio.

Recording can be analog or optical/digital, in either MP3 or WAV. Even better, to load the H140, you don't need special drivers: You can drag folders of ripped songs to it via Windows Explorer. The centrally located joystick selector controls the usual navigation functions and volume, while dedicated buttons control play/pause and record mode and bring up the main menu. And finally, Linux and open-source fans will be pleased to note the presence of an Ogg Vorbis decoder.

The screen is chockablock with information: It shows left/right volume, the codec in use, bit rate, and EQ setting, as well as the usual album, artist, and title listings. Preference controls modify just about every aspect of the H140, including the contrast of both the main LCD and the one on the wired remote. You can also change the way the joystick operates, select vertical or horizontal scrolling, and tailor other user interface features to your liking.

The H140 has a very articulate sound, with strong bass, good highs, and more EQ options than we've seen on any other player. The supplied ear buds are unremarkable, except that they're slightly larger in diameter than most and may not fit smaller ears. But the leather holster/belt clip is very well made and holds the 6.5-ounce unit (4.1 by 2.4 by 1 inches, HWD) securely.

Recording quality is superb. The built-in mic is the best we've heard in a portable unit,

**THE BEST PLAYER** in the 20GB-plus class is the iRiver H140.

**THE RIO KARMA** is also at home as a part of your stereo.

although it picks up the hard drive's whine when it spins up. The included lapel mic eliminates the whine and preserves quality. FM reception of both local and distant stations is excellent, as was its 10 hours of battery life.

A very proficient player, the H140 needs only a top-quality set of earphones to be complete. At roughly \$370, it's a considerable expense, but if you can scrape by with 20GB, the otherwise identical H120 sells for nearly \$100 less.

**iRiver H140**

\$370 street. iRiver America, [www.iriveramerica.com](http://www.iriveramerica.com). ●●●●●

**Rio Karma**

Rio invented the MP3 player as we know it, and it continues to innovate in this currently crowded space. The 20GB Rio Karma has serious geek appeal, because it includes Ogg Vorbis and FLAC (Free Lossless Audio Codec) support in addition to the usual MP3 and WMA codecs. The additional codecs make it especially suitable for Linux as well as PC and Mac.

The Karma's squarish, hand-sculpted shape (5.5 ounces, 3.0 by 2.7 by 1.1 inches, HWD) is inviting, and it comes with a base that brings out both USB

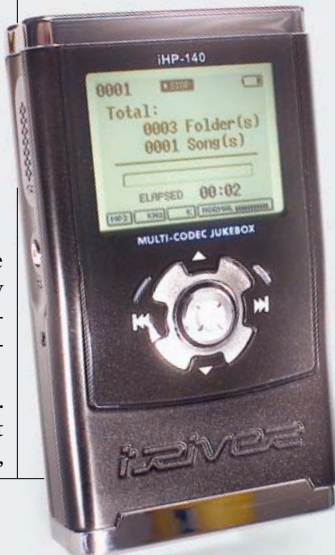

2.0 and Ethernet interfaces, so you can use the Karma on your network. The base also has left/right audio jacks, and it's an ideal bridge between your PC and your stereo system. What's odd about the Karma is the lack of a belt clip or holster; the player is too thick to fit comfortably in most pockets.

The Karma is a pleasure to use. The face of the player has a menu button and a joystick/selector. A real scroll wheel (not a rocker) gives you another means of navigation, and dedicated buttons on the side control the volume. The menu system is very logical and easy to navigate. On-screen displays are quite legible, and the player lasted more than 14 hours on a single charge.

The player sounds very good through the bundled Sennheiser MX300 ear buds, which deliver solid bass and clear highs. Our frequency sweep and pink noise tests show a noticeable roll-off in both low bass and high frequencies, though with the frequency limitations of most compression schemes, you'd never know it. But if you want to drive a high-end stereo system with losslessly compressed files, you'll need to apply bass and treble boost.

The Karma lacks the FM tuner that others in this price range have, but its network and home-stereo connectivity options are a plus.

**Rio Karma**

\$270 street. Digital Networks North America Inc., [rioaudio.com](http://rioaudio.com). ●●●●●

**Frontier Labs L1**

**Pros:** Compact size. Large, legible display. Simple controls. PIM features.  
**Cons:** Nonstandard 2.5-mm jacks. Quirky software.  
**Bottom line:** Lots of features for the price, but this player needs polish.

\$299 direct. Frontier Labs America, [www.frontierlabsamerica.com](http://www.frontierlabsamerica.com). ●●●●○

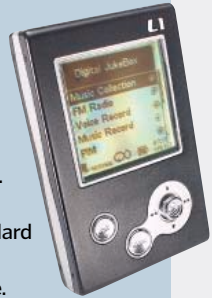

**Philips Recording Audio Jukebox HDD120**

**Pros:** Striking black design, like an anti-iPod. Audio recording function. Wired remote. Very good audio performance and excellent standard ear buds.  
**Cons:** Limited codec support. Separate buttons and screen animations can slow navigation. File management/transfer software is substandard.

**Bottom line:** Pretty functional, with the best standard ear buds on any digital audio player. But the HDD120 could use better ergonomics and better file software.  
\$280 street. Philips Electronics N.V., [www.philips.com](http://www.philips.com). ●●●●○



**PoGo! RipDrive 30GB**

**Pros:** Solidly built. Excellent audio performance. Unique, well-executed software. Doesn't require drivers or special software. Very good FM performance.

**Cons:** Bulky and heavy. Internal mic desperately needs isolation  
**Bottom line:** It's bigger than other players, but the RipDrive is a surprisingly good performer.  
\$299 direct. PoGo! Products Inc., [www.pogoproducts.com](http://www.pogoproducts.com). ●●●●○



[www.pcmag.com/mp3players](http://www.pcmag.com/mp3players)

# HP's Near-Perfect Media Center PC

BY JOEL SANTO DOMINGO

**PC** MAGAZINE EDITORS' CHOICE  
Have you been holding off committing to the Media Center platform to see what makers would come up with next? If so, it's time to look at the **HP Media Center PC m1050y**. What sets the m1050y apart is the work HP has put into the platform to make the unit truly media-friendly—for years to come.

The neatest feature is the HP Personal Media Drive. A slot in the front of the PC's case accepts hot-swappable 160GB hard drive cartridges (\$219 apiece), which you can insert or remove while the system is running. This gives the m1050y unlimited storage potential for your ever-growing collection of music, photo, and video files. It also lets you back up the system's main drive easily and



**A POP-OUT DRIVE** gives you essentially unlimited storage.

safely store irreplaceable files off-site to ward off disaster. Combined with the DVR (digital video recorder) features built into the Windows XP Media Center Edition 2004 OS, the drive also solves the biggest problem with TiVo and other

set-top DVRs: You never have enough storage. HP has also improved the TV quality this time around; on our tests with a good cable signal, TV reception was nice and clear.

The high-end configuration we tested delivered excellent 2D graphics and multimedia performance. In addition, the ATI Radeon X600 PCI Express graphics card helped HP's newest Media Center PC garner respectable 3D gaming scores.

**HP Media Center PC m1050y**

With Intel Pentium 4 560 (3.6 GHz), 1GB DDR 400 SDRAM, 250GB SATA hard drive, 160GB Personal Media removable drive, ATI Radeon X600 graphics, DVD+RW drive, DVD-ROM drive, Creative Sound Blaster Audigy 2 ZS sound card, Klipsch ProMedia THX 5.1 speakers, Microsoft Windows XP Media Center Edition 2004, \$2,876 direct. Hewlett-Packard Development Co., [www.hp.com](http://www.hp.com). OVERALL: ●●●●●. Music: 100 (out of 100); Photo: 100; Video: 99; Gaming: 97.



**Cyberpower Gamer Ultra 9900 Pro**

**Pros:** nVidia GeForce 6800 Ultra card pushes 3D performance to new heights.

**Cons:** Side intake fan and the CPU heat sink fan are loud.

**Bottom line:** This amazingly priced gaming system is worth every dollar. It comes with the components you crave, for less.

\$2,899 direct. Cyberpower Inc., [www.cyberpowersystem.com](http://www.cyberpowersystem.com). OVERALL: ●●●●●. Music: 61 (out of 100); Photo: 68; Video: 83; Gaming: 100.



**Overdrive PC a.Torque FX**

**Pros:** Overclocked processor and graphics equal blazing performance. Quiet fans.

**Cons:** Pricy.

**Bottom line:** The builders at Overdrive PC interview you by phone to

determine your needs, then build a system tailored to you like a Savile Row suit. If you deserve the best and can pay for it, this system is for you.

\$5,999 direct. Overdrive PC, [www.overdrivepc.com](http://www.overdrivepc.com). OVERALL: ●●●●●. Music: 95 (out of 100); Photo: 80; Video: 95; Gaming: 100.

# How Much PC Does \$300 Buy?

BY JOEL SANTO DOMINGO

**S**old by Wal-Mart, the **Microtel SYSWM8001** is notable for two things: It's a full-fledged computer selling for under \$300 (without a monitor), and it runs the Sun Java Desktop System (JDS) on top of a modified version of the SUSE Linux operating system. All things considered, you do get a lot for your money.

The SYSWM8001, based on AMD's low-end 1.6-GHz Duron CPU, is best seen as a second or third home PC. Compared with a \$400 system with Windows or a closeout eMac, it has some limitations. For example, almost all the software sold in your local consumer electronics store is not compatible with the Linux and JDS operating systems. The SYSWM8001's compatibility with printers is also limited, though it does

work with some HP and Lexmark printers. Also, the Microtel lacks a CD burner; the only optical drive is a CD-ROM.

What is it good for? Actually, quite a lot. The StarOffice 7 suite comes preloaded, so you can use word processing and other productivity apps. StarOffice is no match for Microsoft Office, but it can still get the job done, and it lets you open and modify most Microsoft Office documents. The preinstalled browser, Mozilla 1.4 for JDS, was fast at rendering Web pages.

If surfing the Web and working on the occasional Office



**AS A SECOND PC** for Web surfing, this Microtel is fine.

document is all you do, then the SYSWM8001 is fine as a budget alternative to a Windows PC. But if you're going to use store-bought games, business software, and educational titles, think about spending a little more for a Mac or a Windows PC.

**Microtel SYSWM8001**

With 1.6-GHz AMD Duron, 128MB DDR 333 SDRAM, 40GB IDE hard drive, integrated SiS Real 256E graphics, CD-ROM drive, integrated audio, Auditek stereo speakers, Java Desktop System/Linux, \$298 direct. Microtel (distributed by Wal-Mart), [www.walmart.com](http://www.walmart.com). ●●●○○



**HP Pavilion a550e**

**Pros:** Good multimedia performance and software.

**Cons:** Good, not great, 3D performance.

**Bottom line:** The Pavilion a550e makes a good entry point for a person who wants to start getting serious about digital photography and video, with gaming secondary.

\$2,599 direct. Hewlett-Packard Development Co., [www.hp.com](http://www.hp.com). OVERALL: ●●●○○. Music: 90 (out of 100); Photo: 78; Video: 68; Gaming: 80.

[www.pcmag.com/desktops](http://www.pcmag.com/desktops)



# Organize Images with Paint Shop Photo Album

BY BILL MACHRONE

Although previous versions of Jasc's Paint Shop Photo Album had a lot to like, we were awfully frustrated with its interface, which was built on a hierarchical folder system. Competing products—namely Adobe Photoshop Album and Picasa—have proven there are better ways. Now **Paint Shop Photo Album 5** has followed their lead, providing a much improved interface.

You still get the hierarchical folders, but that schema is now supplemented by Calendar and Keyword views. These make it easier to browse through images and find pictures even if you don't know what folder they are stored in. The interface also has new tabs—*Organize*, *Enhance*, *Create*, and *Share*—to help you

quickly get to the tasks and tools you're looking for.

As photo libraries grow in size, managing images that you've backed up to CD or DVD becomes increasingly important. Paint Shop Photo Album's *Catalog* command creates an inventory of the images on your local hard drive and optical discs. It maintains thumbnails of all your images, so you can browse through your entire library, even images that have been transferred to removable media.

The *Enhance* tab includes an easy-to-use correction wizard and simple adjustment tools. Photo Album doesn't provide

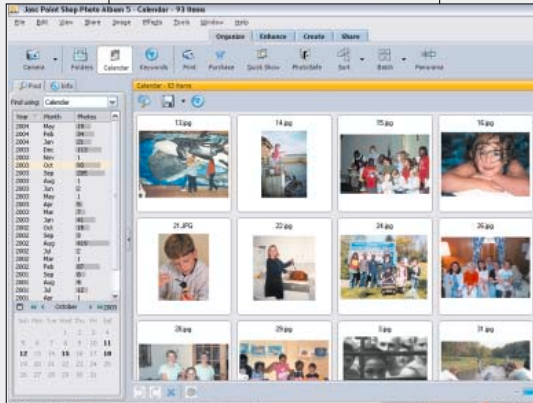

**THE NEW CALENDAR VIEW** in Paint Shop Photo Album 5 lets you quickly see pictures taken on a given day.

the full set of image editing features you get in the company's Paint Shop Pro editing application, but it does offer an impressive set of tools that do a very good job adjusting images. We were blown away by its ability to separate the fore-

ground from the background and adjust their illumination.

Under the *Create* tab, you can make albums, greeting cards, calendars, and more. Wizards guide you through each step, and the resulting projects are attractive. The *Share* tab lets you create Web pages, share images via e-mail, order prints, and the like. You'll

also find a new two-click photo-CD creation tool here.

All told, Paint Shop Photo Album 5 is a fine tool to use to get a handle on your images.

**Paint Shop Photo Album 5**  
\$45 direct. Jasc Software Inc.,  
www.jasc.com. ●●●●●

# NEO Pro Organizes Outlook Mail

BY NEIL J. RUBENKING

Caelo Software's **Nelson Email Organizer Pro 3.0** automatically organizes Microsoft Outlook e-mail for increased productivity. Outlook folders and messages appear inside NEO Pro, and additional tabs group messages by correspondent, category, date range, and more. It uses Outlook categories but renders them more accessible and flexible. Searching is much faster than in Outlook; it supports Boolean, exact phrase, and wild-card searching.

NEO Pro treats current mail and local archives as a single unified message store, where Outlook must search each separately. Like XI and Creo Six Degrees, it creates a full-text index of the message store. On one system, initial indexing of 9,000 messages took five and a half minutes. XI took 13 minutes

but also indexed file attachments; NEO Pro just indexes attachment names.

The program's *Hot* tab replaces the Inbox folder as the center of attention. New mail that's not on the spam blacklist appears in this area's Active Mail folder. After reading a message in the *Hot* tab, you can mark it inactive (it still exists but doesn't clutter the *Hot* tab) or leave it there for further attention. The *Hot* tab also contains items from your To Do list as well as other items you've chosen to mark as hot.

NEO Pro is significantly slower than Outlook at deleting or moving messages, since it must update the index for

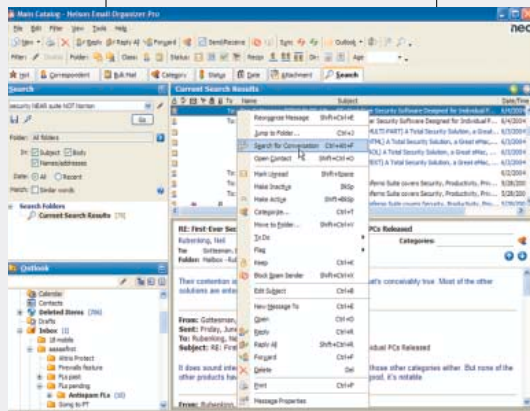

**FINDING A CONVERSATION** or individual e-mail message is fast in convenient with NEO Pro on the job.

each. The integration is generally smooth, but a couple of common actions will trigger Outlook's warning that another program is attempting to send e-mail. Also, NEO Pro does not replace all of Outlook's functions. For example, you can open nonmail ele-

ments (such as Calendar and Notes entries) by clicking on the corresponding folders within NEO Pro, but for that, the program just launches Outlook and has you work there.

For comprehensive indexed searching of e-mail, attachments, contacts, and files, consider XI. But if you just want to use Outlook more productively without adopting an entirely new system, NEO Pro is a good choice, and its search is more flexible than

XI. Home users may find that the less feature-rich NEO Standard 3.0 (\$39.95 direct) suffices, though it lacks the unified message store, *Categories* tab, and Filter toolbar.

**Nelson Email Organizer Pro 3.0**  
\$69.95 direct. Caelo Software Inc.,  
www.emailorganizer.com. ●●●●●

# Google Sets Its Sights on E-Mail—Maybe

BY JIM LYNCH

Every once in a while, a product breaks the mold set by others in a category and forces those established products to improve in order to compete. Google did this with its Internet search engine and is set to do this yet again—perhaps—with its free Web e-mail service, **Gmail**. The catch: The company claims Gmail is just a test service right now and has not committed to rolling it out permanently.

The gigantic 1GB of storage per user—that's roughly 500,000 pages of text—blows away MSN Hotmail (which gives no-fee users 250MB) and Yahoo! Mail (100MB). But it's not the mailbox size limit that got us hooked, it's the service's terrific built-in search feature (no surprise, considering the source). It lets you do a quick,

simple search or use more advanced options to narrow results down. You can also search the Web directly from within Gmail.

Gmail takes an innovative "conversations" view of e-mail threads. This view lets us see entire threads in our Inbox rather than just isolated, scattered messages. We could opt to show all the messages in a thread, close all messages, or click on the title of a message in that thread to view single messages, leaving the rest collapsed. Another attraction for heavy e-mail users: Instead of folders, Gmail uses labels to help categorize mail. Users can apply multiple

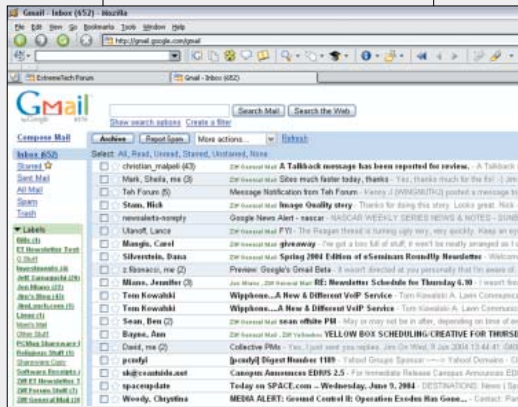

**GMAIL'S INBOX** provides built-in search, easy access to labels, and a snippet of a thread's subject header.

labels to the same piece of mail, which is a far more flexible method than folders.

Gmail isn't perfect. First and foremost, many potential users will be put off by the service's ads—or more precisely, the privacy concerns surrounding

them. Gmail scans your messages and serves up targeted text-based ads based on their content. That has a lot of privacy advocates up in arms and may be too Orwellian for some users. The contacts management is also primitive compared with Yahoo! Mail's more advanced address book.

All of this might be moot, of course, as the service is what the company calls a "limited test" and is invite-only. The company won't divulge details on when—or even if—Gmail will be made widely available.

**Gmail**  
Free. Google, gmail.google.com.  
●●●●●

# Compression and Much More

BY CADE METZ

PentaWare isn't just a ZIP company anymore. Last year the company introduced an eclectic collection of file management tools, and the latest upgrade, **PentaSuite 7.1**, offers everything from file viewing, compression, and encryption to CD and DVD burning, video frame capture, and FTP transfer. This jack-of-all-trades is certainly a good option for a multimedia power user, though PC novices may find the breadth of utilities a little hard to master.

Each of the suite's more than 20 utilities can be launched from a single floating window known as the PentaWare Manager. The apps are divided among six clearly labeled tabs: Compression, Viewer, Encryption, CD/DVD Burning, FTP, and Tools. When you click on a tab, the Manager displays shortcuts to each related utility.

The centerpiece of the Compression apps is, of course, PentaZip, which is among the most versatile ZIP packages. You can seamlessly archive files to CD and DVD, send compressed files via e-mail, schedule regular compressions, and even script simple compression programs.

The suite's most innovative apps fall under the Viewer tab. These include tools for perusing your multimedia files, creating a digital photo album (viewable from a Web browser), and grabbing individual frames from digital videos. With the PentaExif tool, you can quickly search the metadata attached to your photos, sorting pictures by, say, the

date they were taken. With PentaConverter, you can quickly and relatively easily convert large numbers of photos and other multimedia from one file type to another. New in version 7.1 is PentaPDF, which lets you create PDF files from any file format the viewer supports.

The Encryption tab offers a pair of tools, one for encrypting files via PGP and one a wizard for quickly sending such files via e-mail. The CD/DVD Burning apps tab offers a single tool for writing files to disc. The FTP section has an app for uploading files via FTP, and SSL encryption is also available here. The Tools tab includes a standalone app for easily renaming your files.

Sound like a lot? It is—and it may be too much for some users. If you're an experienced PC user constantly juggling files, the suite can certainly be of help. But novices may find the tools aren't as intuitive or tightly integrated as they could be.

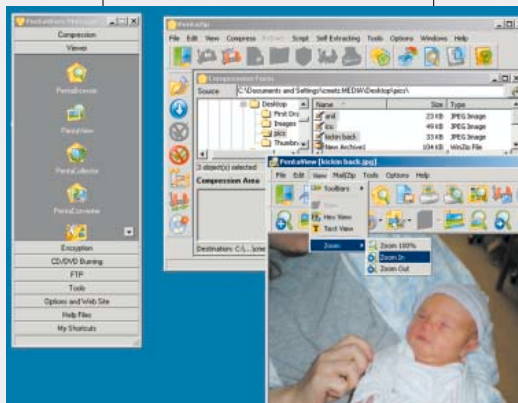

**THE FLOATING TOOL** palette gives quick access to the suite's various components, such as the file viewer.

**PentaSuite 7.1**  
\$99.95 direct. PentaWare Inc., www.pentazip.com.  
●●●●●

# Tiny JVC PC Makes a Big Debut

BY CISCO CHENG

Who would've thought that JVC, best known for its home entertainment products, would be a contender in the ultraportable PC arena? The company's first U.S. model, the **JVC MP-XV841 Mini Note PC**, is based on the Intel Centrino platform and is aimed at the mobile professional. Similar to the Sony VAIO TR5, the Mini Note is an extremely compact (9.2 by 7.0 by 1.5 inches) and lightweight (3.2 pounds system weight) ultraportable that's attractive and well made.

The system comes with a beautiful 8.9-inch-wide screen and a set of features that could give Sony a run for its money. Right below the screen is a button that activates Digital Dolby surround sound, which produces terrific audio for such a compact unit. We watched the entire *Return of the King* DVD

and were impressed with how amazingly crisp and detailed each scene was. We were also pleased to see that the system's battery lasted through the entire movie. The Mini Note delivered an impressive 4 hours 32 minutes on our BatteryMark test, though there's a catch: The standard battery connects to the rear of the unit and sticks out 2 inches beyond the chassis, more like other makers' extended batteries.

When we got down to business, we realized that the tight 15.8-mm key pitch doesn't make the Mini Note as typing-friendly as, say, the TR5. But we did find navigating with the pointing stick a pleasure. The unit contains a built-in DVD/CD-RW combo drive, which eliminates the hassle of carrying external drives. The system also has two USB ports, a FireWire port, 100-Mbps Ethernet, a modem, a Type II PC Card slot, and a

handy SD slot.

The Mini Note uses Intel's Centrino G 2200 wireless solution, resulting in some of the best throughput we've seen for an ultraportable: 21.3 Mbps at close range and 7.9 Mbps at 160 feet. Its scores on Business Winstone (13.1) and Multimedia Content Creation Winstone (11.9) were also good for this class.

The integrated Intel graphics won't get you very far with 3D intensive games but will prove fine for 2D tasks.

All things considered, we prefer the JVC MP-XV841 Mini Note to the Sony TR5—especially considering that the JVC entry is comparably equipped and costs hundreds of dollars less. It still doesn't supplant the IBM ThinkPad X40 as our favorite ultraportable (the IBM's

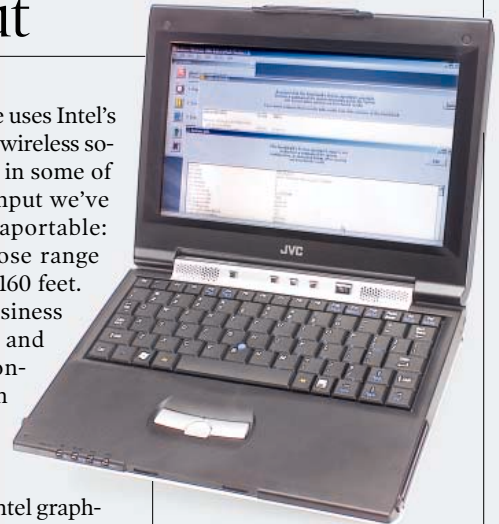

**A JVC PC?**

This entry shows that the company is no newbie.

keyboard and support features are second to none), but in the entertainment-oriented ultraportable niche, the Mini Note is the one to watch.

JVC MP-XV841 Mini Note PC

\$2,399 list. JVC, [www.jvc.com](http://www.jvc.com).



# No-Install Satellite Radio

BY BILL HOWARD

Even jaded technology buffs may let out a low, appreciative whistle when they see

the **Delphi XM Roady2**. Delphi offers a complete 100-channel XM satellite receiver and stock ticker for your car packed into a case roughly the size of an iPod music player.

Until now, to make satellite radio work in your car, you had buy a new car radio or an add-on kit that came with a bunch of wires and took up a lot of room on the dash. With the Roady2, you attach a power cord to the cigarette lighter and run the antenna cable to the roof (it works passably well on your dash, too). That's it. Once

you make a call to XM to activate the service (\$9.95 a month), you're up and running. You don't even need to



**THE TINY ROADY2** brings XM satellite radio to any car.

connect an audio cable to the car radio or cassette player if you don't want to, because an FM modulator is integrated. You simply find an unused FM

frequency to broadcast the signal out through your car speakers. For the best sound quality, though, you'll want to connect to the line-in jack on your car radio, if it has one.

We didn't notice any difference in audio quality between the Roady2 and larger XM satellite tuner modules, nor did the smallish antenna suffer any worse fate than larger antennas do when passing under bridges. If you're under for only a second or so, you'll typically retain the signal; longer, and you'll suffer a couple seconds of silence until the tuner finds the signal again.

In addition to audio, you can get as many as 20 stock quotes

beamed to the display in nearly real time. You'll also be able to buy home and portable boom-box mounting kits for the Roady2—notably, the Cambridge SoundWorks PlayDock XM, a first-rate dock with a power supply, rechargeable batteries, and stereo speakers (\$200 list).

In deciding between Sirius and XM, consumers should consider which has the best programming beyond the common ground of commercial-free rock, rap, jazz, Christian rock, live traffic, and so on. For instance, Sirius offers NPR, NHL, and NFL; XM offers NASCAR, VHI music, and call-in DJs. But when small size and easy installation matter most, the clear advantage right now lies with XM and the Delphi Roady2.

Delphi XM Roady2

\$120 street. Delphi Corp.,

[www.shopdelphi.com](http://www.shopdelphi.com).

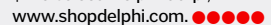

**ANOTHER EXPERT WEIGHS IN ON  
THE TCO OF WINDOWS AND LINUX.**



*"We got to market six months faster, and saw 14 percent in cost savings over Linux, using Windows Server System.™"*

*—Owen Flynn, Chief Technology Officer  
Equifax Inc*

Equifax, a leading provider of consumer and commercial credit information, chose Windows Server System because it allowed them to deliver new and improved services with a 14 percent savings in total cost of ownership. With their new Windows-based supercomputer cluster, Equifax is able to manage its database of over six billion data components with dramatic increases in performance and efficiency. To get the full case study, other case studies, or third-party findings, visit [microsoft.com/getthefacts](http://microsoft.com/getthefacts)



# A PDA for the Grown-Up Gamer

BY JENNIFER DEFELO

If you like to play games and need to get yourself organized, the **Tapwave Zodiac** may be a perfect fit. This portable gaming console also doubles as a very capable PDA. Or else it's a PDA that doubles as a very capable portable gaming console. Either way you look at it, you may never look at your work-a-day PDA the same way again.

The Zodiac comes in two memory configurations: the Zodiac 1 (which we tested) with 32MB of memory (\$299 direct) and the Zodiac 2 with 128MB (\$399). Compared with mainstream PDAs, the Zodiac 1 is slightly larger and heavier (6.3 ounces). The device is sturdy and comfortable to hold, and the 3.8-inch backlit transreflective screen is amazingly clear and crisp. The half-

VGA (480-by-320) resolution made everything a true treat for the eyes—from game play and video watching to reading text files.

When listening to MP3s, playing Duke Nukem, or viewing the *Shrek 2* movie trailer, all sans headphones, we were impressed by the sound produced by the on-board Yamaha audio circuitry and the two tiny stereo speakers. And during numerous rounds of *Stuntcar Extreme*, the vibration we felt when we crashed added nicely to the overall sensory experience. (Other popular titles now available include *DOOM II*, *Spyhunter*, and *Tony Hawk's Pro Skater 4*.)

The Zodiac runs on Palm OS 5.2, the same as the recently re-

viewed Palm Zire 72 (also \$299 direct; First Looks, June 22). The OS here, however, is customized to make the most of the



**IS IT A GAME CONSOLE or a PDA? The Zodiac is both.**

Zodiac's unique gaming form factor. For example, the menus are intuitively laid out to work with the joystick. If you don't like the joystick, you can use

the stylus housed at the back of the device.

We do have a few complaints. First, the joystick seems a little sensitive in some situations, like when you're playing Atari's *Breakout*. Also, the stylus positioning in the back isn't ideal; it's too easy to knock off, especially if dropped into a jacket pocket or cluttered bag.

If you want more out of your PDA than a contact database, calendar, and calculator, then consider the Tapwave Zodiac. Though it may not be appropriate for the boardroom, if you like games and want to be better organized, it's worth checking out.

**Tapwave Zodiac 1**  
\$299 direct. Tapwave Inc., [www.tapwave.com](http://www.tapwave.com). ●●●○○

# Nokia N-Gage Gets a Little Better

BY PETER SUCIU

With its smaller size and better design, the **Nokia N-Gage QD** is vastly improved compared with the company's original phone/game console hybrid.

The new design addresses the biggest complaint of the original—namely, the absurd need to open up the device and remove the battery to change games—but still fails to excel as either a game device or a handset.

Users can now hot-swap the MMC media into an accessible external bay at the bottom of the unit. And once a game is inserted, it will auto-execute, so you don't have to scroll through the menu system to launch a title. The new QD is backward-compatible with all original N-Gage titles, including

*Tony Hawk's Underground* and *The Sims*, while future games will be playable on both device versions as well.

Although compact compared with other game handhelds, this



**WE LIKE THE N-GAGE'S** more intelligent design but still aren't sold on it.

device is still a behemoth as a phone (5 ounces, 4.7 by 2.7 by 0.9 inches, HWD). Thanks to the phone, however, a multi-player gaming experience is possible without any cables.

The N-Gage Arena launcher app makes connecting to Nokia's online gaming service very easy via a click from the main menu. You can also connect short range via Bluetooth to other N-Gage users.

The front panel and interface is more streamlined and the screen slightly brighter: same dimensions (1.6 by 1.4 inches) but with 176-by-208 resolution. Controls are more comfortable, and the unit's eight-way D-Pad has been adjusted to make it feel more like a console controller. The numeric dial pad's buttons, which double as game controls, have been raised a bit and have a bit more travel. The 5 and 7 keys are used more often than the other keys for gaming and thus have been made to stand out with beveled circles so that you can

find them without taking your eyes off the screen.

What's been dropped is probably what users will miss the least. The built-in radio and MP3 functions are gone, and unlike the original N-Gage, the QD is not a tri-band but a dual-band GSM (850/1900) phone. It uses the same Symbian 6.0 OS found on other Nokia handsets, which gives you full contact, schedule, and e-mail ability.

In the end, the biggest hurdle for the N-Gage will be the continued lack of software titles available. Although several publishers, including Atari and Capcom, have announced plans to release titles for the system, the game selection (which currently includes games from Activision and Electronic Arts among others) remains vastly overshadowed by Nintendo's Game Boy Advance.

**Nokia N-Gage QD**  
\$99 direct with service, \$199 without. Nokia, [www.n-gage.com](http://www.n-gage.com). ●●●○○

# Kyocera Joins the Superzoom Party

BY GLENN MENIN

**K**yocera enters the realm of superzooms (cameras with optical zoom lenses of 10X or higher) with the 4-megapixel **Kyocera Finecam M410R**. Kyocera claims its RTune technology improves speed and quality. The M410R's speed is indeed impressive in some areas: In continuous-shooting mode, it can shoot at 3.3 frames per second until the images fill up your memory card. But we wish the camera had image stabilization, and although it produced good images, they weren't as sharp as those of our Editors' Choice in this class, the Olympus Camedia C-765 Ultra Zoom ("Superzooms," June 22, page 125).

The 10X optical-zoom lens is impressively fast, and the zoom rocker for it is located on the upper right of the rear panel.



**IN BURST MODE**, the M410R can shoot nonstop until the card is full.

The 1.5-inch LCD screen feels small but performs well in sunlight. We like that you can shoot full-frame video (640-by-480 with audio) at 30 frames per second if you use a high-speed SD card.

The M410R's 3.4-second

boot time is around the median for digital cameras in general, but it's the fastest of any of the superzooms that we've tested. Recycle time was slow, at 5.3 seconds with the flash enabled.

The camera's 1,100 lines of resolution are about average for a 4MP sensor, and its pixel transition score of 2.3 percent is good. Our simulated daylight shots were clean, with good color (though slightly warm) and good exposure. Flash results were clean, with good color, but the whites were somewhat blown out.

The Kyocera Finecam M410R is certainly worth a look. It isn't perfect, but its continuous-shooting ability may win you over.

**Kyocera Finecam M410R**

\$500 street. Kyocera Corp., [www.kyocera.com](http://www.kyocera.com). ●●●●○

# Olympus Expands Superzoom Line

BY GLENN MENIN

**T**he Olympus Camedia C-765 Ultra Zoom recently won our Editors' Choice in the superzoom category ("Superzooms," June 22, page 125), thanks to good image quality and compact design. The company has since expanded the Ultra Zoom line

with the 4-megapixel **Olympus Camedia C-770**, which adds better video, a twin-bulb flash, a hot shoe, and more metal on the body for \$100 more. But the C-770 suffers from many of the C-765's limitations, including mediocre speed and the lack of both lamp-assisted auto-focus and optical image stabilization (recommended for shooting at over 7X zoom without a tripod). Surprisingly, the C-770 also scored slightly lower than the C-765 on our resolution tests, despite having the same optics and image sensor.

Boxy yet comfortable, the smallish C-770 is easy to hold and suited to one-handed shooting. The zoom lens is smooth and responsive; you can operate it easily via the rocker control near the shutter button. Users can access an impressive array

of manual controls, but these are often buried in cryptic menus. A button lets you toggle between the clear, bright electronic viewfinder (with diopter) and the crisp 1.8-inch LCD.

Lab results were good for this class of camera, with 1,150 resolvable lines and 2 percent pixel transition average. With the camera in fully automatic mode, we noted some blowout in whites in both our simulated daylight and flash still-life studies, but otherwise the images were crisp and bright, with good colors. On the downside, the C-770's performance was slow: Boot-up took 7.7 seconds, and the recycle time between shots (with the flash enabled) came to 2.5 seconds.

**Olympus Camedia C-770 Ultra Zoom**

\$599.99 list. Olympus America Inc., [www.olympusamerica.com](http://www.olympusamerica.com). ●●●●○



**THE C-770 IS A FINE CHOICE**, but we prefer its less-expensive sibling.

## Concord Eye-Q 5345z

**Pros:** Sharp pictures. Extremely easy to use.  
**Cons:** Lack of options, controls, and ports. Slow recycle time, no burst mode.

**Bottom line:** This is a 5-megapixel point-and-shoot model for those who don't want a complicated camera. It's not fast, but it produces sharp images.

\$379.99 list. Concord Camera Corp., [www.concordcam.com](http://www.concordcam.com). ●●●●○



## Kodak EasyShare LS753

**Pros:** Sleek, handy design. Crisp, well-exposed images. Quick shooting.

**Cons:** Our tests show somewhat low resolution for a 5-megapixel camera.

**Bottom line:** Sharp pictures and a rich feature set make the handy LS753 a good choice for snapshots. The fact that its 4MP (and \$50 cheaper) cousin did better on our tests, however, makes the LS743 a better choice over the LS753.

\$399.95 list. Eastman Kodak Co., [www.kodak.com](http://www.kodak.com). ●●●●○



## Konica Minolta DiMage G600

**Pros:** Least expensive 6-megapixel camera we've tested.

Solid feel, easy to shoot with.  
**Cons:** Flash shots have a green cast, with muddy shadows.

**Bottom line:** This solid 6MP compact camera produces sharp images. Enthusiasts will appreciate the depth of the controls, but novices will be disappointed that the camera offers only one preset mode.

\$400 street. Konica Minolta Photo Imaging U.S.A. Inc., [www.minoltausa.com](http://www.minoltausa.com). ●●●●○



[www.pcmag.com/cameras](http://www.pcmag.com/cameras)

# Why Stop at 17?

BY ALFRED POOR

**B**uyers who are looking for a big-screen monitor and can afford an LCD model may find the 20-inch **NEC MultiSync LCD2060NX** worthy of attention. At \$1,100 (street), it costs more than a pair of 17-inch monitors, but excellent image quality and features make a strong case for considering it.

The display base provides tilt, swivel, and height adjustment. The unit has both digital and analog connections, but only an analog cable is included in the box (an odd oversight at this price level). Printed documentation is far better than usual for monitors, with lots of information and useful illustrations. The control buttons on the front panel are small, but you don't need to use them if you download the free NaViSet utility from the company's Web site: This handy program lets

you control all settings from your keyboard.

The panel has a native resolution of 1,600 by 1,200 pixels—nearly 100 pixels per inch—for a sharp, finely detailed image. On our tests with DisplayMate ([www.displaymate.com](http://www.displaymate.com)), we observed top-notch image quality. There were no apparent pixel defects, and gray-scale response was excellent for both light and dark shades. Viewing-angle performance was well above average, color tracking was good, and we saw no ghosting or streaking. Analog color ramps were smooth, though some faint discontinuities were visible on color ramps when we used a digital signal. The auto-sync feature left slight pixel jitter in the



**A BEAUTIFUL IMAGE** makes the MultiSync LCD2060NX worth the expense.

image, but we were able to eliminate it with a small tweak of the timing settings. Moving images revealed some smearing, but this is to be expected for a panel with a 25-ms pixel response.

**NEC MultiSync LCD2060NX**

\$1,100 street. NEC-Mitsubishi Electronics Display of America Inc., [www.necmitsubishi.com](http://www.necmitsubishi.com). ●●●●○

**ViewSonic VP201s**

**Pros:** High resolution. Portrait and landscape modes.  
**Cons:** Some image-quality flaws.  
**Bottom line:** The 20-inch ViewSonic VP201s is a big-screen, high-res LCD with a low price for its size. It has some attractive features, but it also has some flaws that make it less appealing than some alternatives.

\$1,050 street. ViewSonic Corp., [www.viewsonic.com](http://www.viewsonic.com). ●●●●○



**Dell 3300MP**

**Pros:** Wall-filling brightness. Hard-shelled carrying case.  
**Cons:** Uses special cables not widely available. Some minor image-quality flaws.  
**Bottom line:** Priced aggressively for an XGA projector weighing less than 4 pounds, the Dell 3300MP delivers a heavyweight punch in terms of brightness. Its flaws and idiosyncrasies are few and relatively minor, making it an attractive overall value.

\$1,699 direct. Dell Inc., [www.dell.com](http://www.dell.com). ●●●●○

**HP f2304 23-inch High-Definition LCD Monitor**

**Pros:** Very good color and gray-scale tracking. Works very well as a PC monitor and well as a home entertainment display.  
**Cons:** No remote. Off-axis viewing is not especially good.  
**Bottom line:** Destined to be primarily a PC display, the f2304 can also handle some part-time duty as an HDTV monitor.

\$2,099 direct. Hewlett-Packard Development Co., [www.hp.com](http://www.hp.com). ●●●●○



# Affordable Big-Screen LCD

BY ALFRED POOR

**W**ith an aggressively low price of \$650 street, the 19-inch **Envision EN9250** LCD monitor comes with lots of bonus features and performs well, making it an appealing bargain.

Some value-priced monitors have bases that only tilt; the EN9250's base tilts and swivels, the monitor's height is adjustable, and the panel rotates to portrait mode. To take advantage of this, Portrait Display's Pivot Pro utility comes bundled with the display.

To sweeten the deal further, the monitor has both analog and digital connectors—it even comes with cables for both—and a pair of built-in speakers better than average for

monitor speakers, though not as good as most desktop speakers.

On our image-quality tests, done with DisplayMate ([www.displaymate.com](http://www.displaymate.com)), the auto-sync function did an excellent job of setting

the pixel timing. There were no apparent pixel defects, and brightness uniformity looked good. Viewing-angle performance was excellent in the horizontal plane and fairly good in the vertical, with a noticeable hue shift occurring at about 65 degrees above perpendicular. Color ramps were smooth, and color tracking was excellent. The only weak area was in light-gray response with an analog signal, though the digital signal performance was fine.

The Envision EN9250 is not perfect, but it's a solid performer. And at a price near that of many 17-inch monitors with premium features, it's a bargain.

**Envision EN9250**

\$650 street. Envision Monitors, [www.envisiondisplay.com](http://www.envisiondisplay.com). ●●●●○



**A BARGAIN PRICE** gets you good image quality and a few extras.



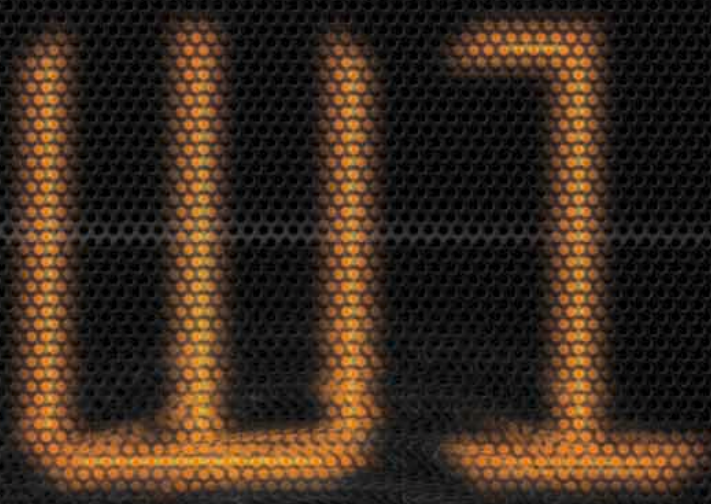

## Boom, boom! Take me to your room.



W1's minimalist, brushed aluminum design is modern enough to turn heads, yet classy enough to always be in style. The widescreen display and open workspace provide a distraction free environment. And when it's time to party the 4 channel surround sound and subwoofer fill the room with sound so rich, you won't believe it is coming from a notebook.

- \* Intel® Centrino™ Mobile Technology
- \* Microsoft® Windows® XP Professional
- \* ATI Mobility™ RADEON™ 9600 graphics processor
- \* 15.4" 1680x1050 widescreen display
- \* 4.1 surround sound stereo system with built-in subwoofer
- \* Built-in DVD±RW drive and 802.11g wireless
- \* 80GB 5400 RPM hard drive
- \* ASUS Power saving technology for up to 4.5 hours of battery life

**ASUS**<sup>®</sup>  
<http://usa.asus.com>



ASUS Recommends Microsoft® Windows® XP

# Exchange Your Mail Server

BY JOHN CLYMAN

If your company is running Microsoft Exchange 5.5 or 2000 and you're resisting the upgrade to Exchange 2003, several companies offer alternatives that provide e-mail and basic groupware capabilities that work both in Microsoft Outlook (via a client plug-in) and through Web-mail interfaces. We tested two new versions.

## Gordano Messaging Suite

Gordano Messaging Suite is now available with collaboration capabilities, adding it to the lineup of full-spectrum and lower-cost alternatives to Microsoft Exchange. GMS components are sold piecemeal, so pricing is complicated. Fortunately, server installation is a cinch: Just complete a few wizardlike dialog boxes to install the components you select. A Web-based interface lets you perform administrative tasks from anywhere.

The basic GMS Mail server supports core e-mail protocols and features such as authentication and LDAP directory integration. It does not support native MAPI. To add Exchange-like capabilities such as centralized calendaring, you'll need the GMS Calendaring and GMS Collaboration modules. The components are well integrated; for example, if you use GMS Instant Messenger, it can automatically e-mail a transcript to participants when a conversation is complete.

GMS provides a feature called Autoport, which enables easy migration from Exchange Server. The program pulls account information directly from Exchange as users log on. The GMS Collaboration component lets you enable public folders, meeting invitations, and other Exchange-dependent features from within Outlook.

You don't need Outlook to

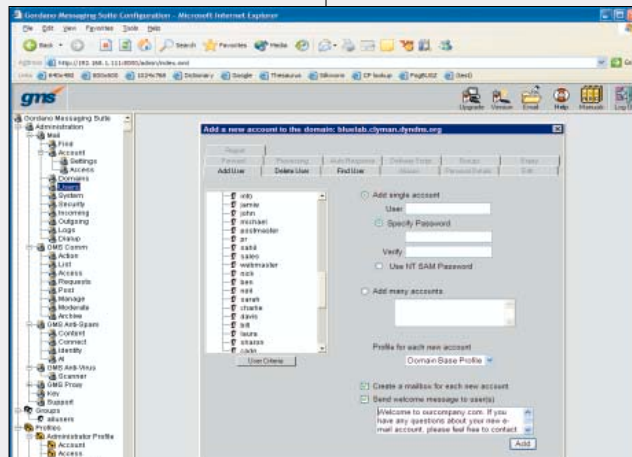

**GORDANO'S WEB-BASED** administrative interface lets you configure the server from any machine with a browser.

access collaboration features, though, since Gordano's Web-mail interface provides a substitute. You can select either a Professional version or an Express version (which is optimized for low-bandwidth connections). A version for mobile devices is available, too. The Professional version attempts to duplicate some native-client features in a Web interface but succeeds only partially; drag-and-drop, for example, works for filing mail messages but not for rescheduling calendar appointments. We also found that recurring meetings created in Outlook appeared only on their initial date in the Web client, and that printing calendars proved problematic.

Optional GMS components integrate antispam, antivirus, and listserv support. This smorgasbord of components illustrates where Gordano's offering shines: GMS offers lots of flexibility for assembling the right components to meet your collaboration goals.

### Gordano Messaging Suite

\$2,195 direct for 50 users, including core server, Web-mail interface, calendaring, and Outlook-based collaboration features. Gordano Ltd., [www.gordano.com](http://www.gordano.com). ●●●●○

## Scalix 9.0

Designed to replace or coexist with Microsoft Exchange Server, the Scalix 9.0 e-mail and calendaring platform provides many comparable features and offers easy client-side deployment. We found that Scalix's native MAPI support enabled effective integration with Microsoft Outlook, and we like the rich interface of its Web-mail client.

Installing the Scalix server requires a number of steps, but they're well within the grasp of anyone with moderate Linux system-administration skills. Scalix provides a simple Web-

based interface for managing users and groups, though more advanced administrative features are available only through command-line tools, which also enable batch processing and scripting.

As with most products positioned as replacements for Exchange, Scalix provides two ways to access its groupware capabilities beyond basic POP and IMAP mail. One way is to install a client plug-in that works with Outlook; the other is to use a Web-mail interface. Scalix deserves kudos for making the plug-in installation painless.

The Web client includes such conveniences as drag-and-drop rescheduling and on-the-spot address expansion and verification. We particularly like its incremental search, which lets you locate particular messages or contacts easily. The Web client supports mail, calendars, contacts, and public folders, but not tasks or rules. Scalix also comes with hooks to attach third-party antispam and antivirus solutions.

If you're looking for a gentle way to change to a Linux-based mail and groupware solution, Scalix 9.0 is well worth your attention.

### Scalix 9.0

Direct price: \$60 per client access license. Scalix Corp., [www.scalix.com](http://www.scalix.com). ●●●●○

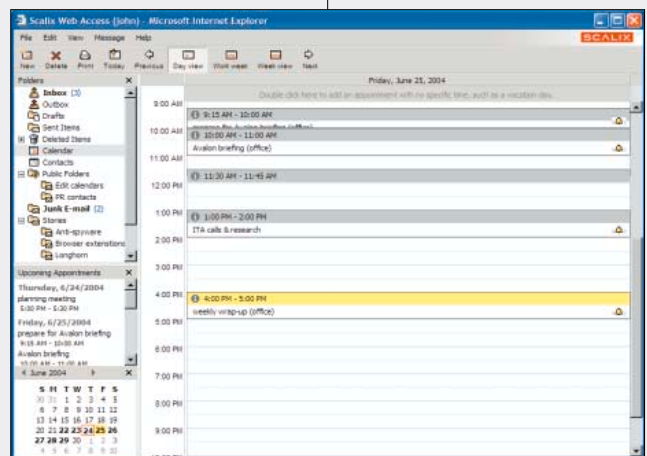

**SCALIX'S WEB** client provides conveniences like drag-and-drop rescheduling and immediate completion of e-mail addresses

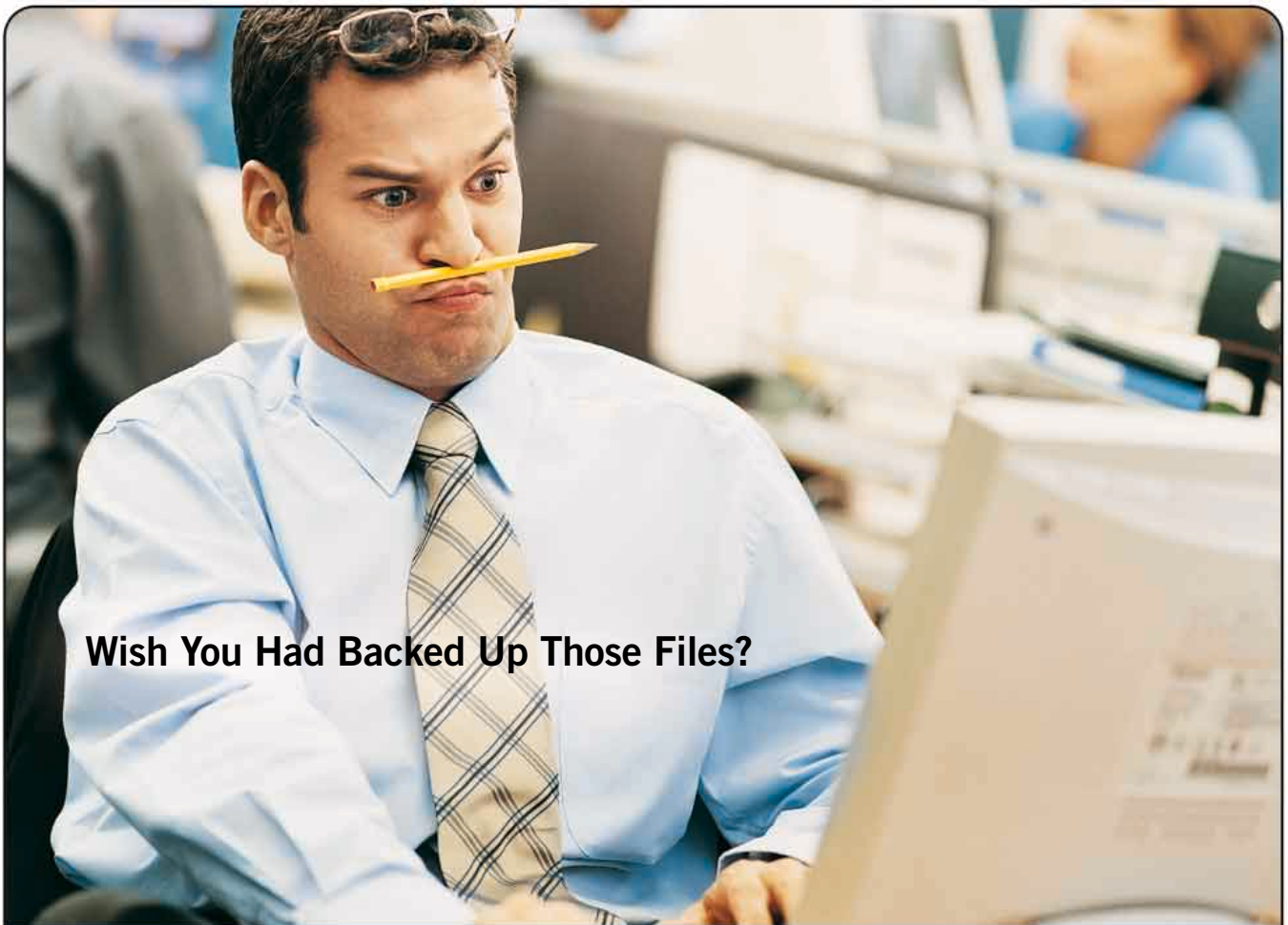

**Wish You Had Backed Up Those Files?**



**With the Mirra Personal Server™ backup is hands free and worry free.**

The new Mirra Personal Server makes it easy to back up your files so you'll never have to worry again. Every time you save or create a new file, Mirra instantly backs it up and versions it, no schedules to set up, no buttons to push. Worry and hassle free.

And what can you do with those up-to-the-minute copies? That's where the magic begins. Restore a lost file. Search for an earlier version. Instantly share a photo or file. Even remotely access any of your files securely over the web from anywhere. Put Mirra to work for you for as little as \$399.



**The Mirra Personal Server.** All-in-one solution for file protection and access—anywhere, anytime.

 <p><b>Continuous Backup</b></p> <ul style="list-style-type: none"> <li>&gt; Every time you save, it's backed up</li> <li>&gt; Backs up files from multiple PCs</li> <li>&gt; Copies files, photos, email, data</li> </ul>	 <p><b>Instant File Share Over The Web</b></p> <ul style="list-style-type: none"> <li>&gt; Share files or photos without uploading</li> <li>&gt; Eliminate email or ftp of large files</li> <li>&gt; All sharing is private, secure and free</li> </ul>	 <p><b>Free Secure Remote Access</b></p> <ul style="list-style-type: none"> <li>&gt; File access via any web browser</li> <li>&gt; It's free, no monthly fees</li> <li>&gt; Secure encrypted downloads &amp; access</li> </ul>
--	--	--

*“An excellent insurance policy against losing precious data.”*

*– Wired Magazine*

Wish you could own one? Call 866-647-7248 now or go to [www.mirra.com/pc](http://www.mirra.com/pc)





IBM ThinkPad X Series

## GO with IBM Think Express Program

IBM ThinkExpress models are designed, configured and priced with small to medium-size businesses in mind.

CNET Editors Choice Award, March, 2004  
IBM ThinkPad X40

**\*Availability:** All offers subject to availability. IBM reserves the right to alter product offerings and specifications at any time, without notice. IBM is not responsible for photographic or typographic errors. **Pricing:** does not include tax or shipping and is subject to change without notice. Reseller prices may vary. **Warranty:** For a copy of applicable product warranties, write to: Warranty Information, P.O. Box 12195, RTP, NC 27709, Attn: Dept JDJA/B203. IBM makes no representation or warranty regarding third-party products or services. **Footnotes: (1) Mobile Processor:** Power management reduces processor speed when in battery mode. **(2) Wireless 11a, 11b and 11g:** based on IEEE 802.11a, 802.11b and 802.11g, respectively. An adapter with 11a/b, 11b/g or 11a/b/g can communicate on either or any of these listed formats respectively; the actual connection will be based on the access point to which it connects. **(3) Included software:** may differ from its retail version (if available) and may not include user manuals or all program functionality. License agreements may apply. **(4) Hard drive:** GB = billion bytes. Accessible capacity is less; up to 4GB is service partition. **(5) Memory:** For PCs without a separate video card, memory supports both system and video. Accessible system memory is up to 64MB less than the amount stated, depending on video mode. **(6) Limited warranty:** Support unrelated to a warranty issue may be subject to additional charges. **(7) ServicePac services:** are available for machines normally used for business, professional or trade purposes, rather than personal, family or household purposes. Service period begins with the equipment date of purchase. Service



Protect your data against accidents when you're on the road. Accidents definitely do happen. Especially when you're working wirelessly. Which is why you should have an IBM ThinkPad® notebook with Intel® Centrino™ Mobile Technology. Select ThinkPad notebooks are the only PCs designed to sense a fall and, within 500 milliseconds, park the hard drive's read/write head. Kind of like an airbag for your data. To view a demo, visit [ibm.com/shop/m454](http://ibm.com/shop/m454). You'll see why select IBM ThinkPad notebooks with Intel Centrino Mobile Technology give wireless users the confidence to tackle almost anything – networking, presentations, even the occasional meeting with the pavement. And go from “oh, #@\*^!” to “phew” in less than a second.

Klutz-proof wireless. Only on a ThinkPad.

1 866 723-1840 | [ibm.com/shop/m454](http://ibm.com/shop/m454)



## NEW! IBM ThinkPad R51

Ultimate Value

### Distinctive IBM Innovations:

- IBM Active Protection System – Helps protect your hard-drive from falls

### System Features:

- Intel® Centrino™ Mobile Technology
  - Intel Pentium® M Processor 1.50GHz<sup>1</sup>
  - Intel PRO/Wireless Network Connection 802.11b/g<sup>2</sup>
- Microsoft Windows XP Professional<sup>3</sup>
- 14.1" XGA TFT display (1024x768)
- 256MB DDR SDRAM<sup>5</sup>
- 20GB hard drive<sup>4</sup>
- Ultrabay™ Enhanced CD-RW/DVD-ROM combo
- IBM UltraConnect™ Antenna for increased signal strength<sup>12</sup>
- 1-yr system/battery limited warranty<sup>6</sup>

NavCode 28832XU-M419

THINK EXPRESS MODEL PRICED AT: **\$1,299\***

ServicePac® Service Upgrade:<sup>7</sup>

3-yr Depot Repair #30L9192 **\$132**

## IBM ThinkPad X40

Our thinnest and lightest

### Distinctive IBM Innovations:

- IBM Active Protection System – Helps protect your hard-drive from falls
- NEW! IBM Rescue and Recovery™ with Rapid Restore™ – One-button recovery and restore solution

### System Features:

- Intel Centrino Mobile Technology
  - Intel Pentium M Processor ULV 1GHz
  - Intel PRO/Wireless Network Connection 802.11b
- Microsoft Windows XP Professional
- 12.1" XGA TFT display (1024x768)
- 256MB DDR SDRAM
- 20GB hard drive
- Integrated Gigabit Ethernet and modem
- Legendary IBM full-size keyboard<sup>8</sup>
- Only .94" thin<sup>11</sup>
- 2.7-lb travel weight<sup>10</sup>
- 1-yr system/battery limited warranty<sup>6</sup>

NavCode 23861CU-M419

THINK EXPRESS MODEL PRICED AT: **\$1,499**



**Stop wishing  
they could do  
two things at once.  
And let them.**



**Hyper-Threading Technology  
from Intel. It's all about productivity.**

There's no magic potion to get a workforce working harder. There is, however, the power of PCs built upon the Intel® Pentium® 4 Processor with HT Technology. Hyper-Threading Technology was smartly designed to achieve performance gains of up to 25% when running two applications at once.\*

For details, visit [intel.com/business](http://intel.com/business).



\*Look for systems with the Intel® Pentium® 4 Processor with HT Technology logo which your system vendor has verified utilize Hyper-Threading Technology. Performance will vary depending on the specific hardware and software you use. See [www.intel.com/info/hyperthreading](http://www.intel.com/info/hyperthreading) for information. ©2004 Intel Corporation. Intel, Intel Inside and Pentium are trademarks or registered trademarks of Intel Corporation or its subsidiaries in the United States and other countries. All rights reserved.

# FEEDBACK

“There is an eager market awaiting microchipping: potential kidnapping targets in South America.”



## CELL PHONES ON AIRPLANES REVISITED

As a professional pilot, I'd like to reply to "Inside Track" in your November 5, 2002, issue, which I recently came across. In it, John C. Dvorak discounts the danger of cell-phone use on aircraft. While the real reason for the ban on cell phones in flights perhaps hasn't been explained well to travelers, the dangers are clear to those of us in the know.

Cell phones, as well as other personal electronic devices (PEDs) such as laptops and CD players, emit signals from high-frequency clock oscillators. The resulting electromagnetic interference (EMI) can affect aircraft navigation, communication, and control systems. Switched-on cell phones have been proven responsible for spurious warnings about smoke, fuel tank imbalances, and the like, resulting in flight delays. In a particularly scary incident, a Boeing 747 landing at Heathrow suddenly yawed to the right and climbed inexplicably; it was later found that a cell phone had interfered with the aircraft's fly-by-wire system.

Can you afford to depart 2 hours late because a passenger forgot to switch off his mobile? Run out of fuel? Or, God forbid, flip over and crash over London? All these scenarios are possible, and that's the real reason the use of such devices is banned.

Most aircraft flying today were built when PEDs were in their infancy, and their interference with aircraft systems was not an issue. Also, PEDs are not designed to such stringent norms as aircraft electronics. Unfortunately, re-laying cables to eliminate EMI is extremely expensive; that's why there are problems on older airplanes. Take heart, though: The latest airliners from Airbus and Boeing cater to the use of such devices, and many long-distance flights now offer broadband Internet.

ATUL BHATIA

## GETTING MICROCHIPPED

In his excellent article on microchipping (July issue, page 75), Bill Machrone missed a potential category for chip implants: humans.

There is an eager market awaiting microchipping: potential kidnapping targets in South America, mainly Argentina, Brazil, and Colombia. Take Brazil, where "flash kidnapping" is booming: People are held for a couple of hours, during which their credit cards are hit. If a card is maxed out, kidnappers call the relatives to top

off the account, or else. Some potential targets (affluent adults, managers, and parents of schoolchildren) are eagerly awaiting RFIDs to help others locate them quickly should they go missing. A few entrepreneurs have already been roaming security exhibitions in Korea and Taiwan for human-tolerated RFIDs.

Science fiction got it slightly wrong: Governments may not be the ones to impose implanted chips; instead, people will ask for them in order to protect themselves. Ironic, isn't it?

STEPHANE MAES

## AN ALARMING RECOMMENDATION

I was disappointed to read Neil J. Rubenking's praise of ZoneAlarm Security Suite 5 (July issue, page 64). This sentence caught my eye: "ZASuite monitors your antivirus program and alerts you if it becomes disabled...." The fact is, ZoneAlarm's firewall can disable your AV program while telling you it's working fine. This happened when I "upgraded" to 5.0 (the free standalone firewall version, but many Pro users have had similar or worse experiences). The ZA forum at [forum.zonelabs.org/zone/boards/board.id=inst](http://forum.zonelabs.org/zone/boards/board.id=inst) is filled with pages of such complaints. Zone Labs has turned into an organization that is not to be trusted, and any review of any of its products should note this.

HYLEN SMURR

## REVVING UP A LEMON?

I could not believe Bill Machrone's glowing review of Iomega's Rev 35 (Editors' Choice and perfect 5 rating, June 22, page 67).

I owned Iomega Zip and Jaz Drives for several years. During that time both drives failed and were replaced ten times, and their respective disks failed more than two dozen times.

Since there was no real competition to these products, I kept using them until they were discontinued. When they failed after that, Iomega technicians suggested that I buy their refurbished counterparts. Are they joking? I would rather spend the extra time burning DVDs than entrust my data to such inferior products.

ORI STEINBERG

## How to Contact Us

We welcome your comments and suggestions.

When sending e-mail to Letters, please state in the subject line of your message which article or column prompted your response.

**E-MAIL** [pcmag@ziffdavis.com](mailto:pcmag@ziffdavis.com)

**MAIL** Letters, *PC Magazine*, 28 East 28th Street, New York, NY 10016-7940.

All letters become the property of *PC Magazine* and are subject to editing.

We regret that we cannot answer letters individually.

## Corrections and Amplifications

■ In the June 22 story "VoIP: The Right Call," we incorrectly listed International Computer Graphics as one of the big national providers of hosted services in the United States and Canada (page 146). The correct company is ICG Communications Inc. ([www.icgcomm.com](http://www.icgcomm.com)).

■ Because of insufficient data about NOD32's ability to detect unknown viruses, the review of the product that appeared in our June 8 issue (page 115) has been removed from our Web site.

■ In our 2004 Utility Guide (June 8, page 122), we incorrectly said that only SoftInform's FineBrowser lets you open multiple Web sites simultaneously. Other browsers, including MyIE2, let you do much the same thing.



Hardware Sensor and  
Software Included

# Produce stunning photos like the pros.\* Color correct your monitor in minutes with ColorPlus™

- Recommended for all digital camera enthusiasts
- Corrects your monitor for accurate and reliable color
- Simple-to-use and affordable
- Save time, paper and ink
- Includes Adobe® Photoshop® Album Starter Edition
  - FREE technical support
  - To find out more about digital color, visit [colorvision.com](http://colorvision.com)



\*Pros correct their monitors once a month. Now you can do it at home.

ColorPlus is available at these and other retailers



Pantone® and other Pantone, Inc. trademarks are property of Pantone, Inc. ColorVision® and other ColorVision, Inc. trademarks are the property of ColorVision, Inc. Adobe and Photoshop are registered trademarks of Adobe Systems, Incorporated. © Pantone, Inc. 2004. All rights reserved.



# Bill Machrone

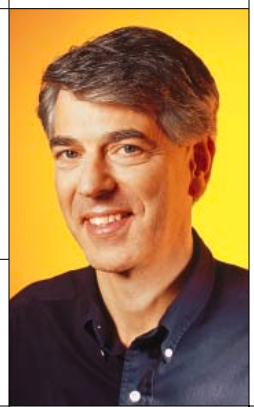

## A Musical Summer

**S**ummertime is self-improvement time. It's the time of year that I always earmark to learn something new or undertake a large project—or even multiple projects. This year, I'm taking down the big Lionel train table and building a new electronics workbench. My basement is already subdivided into woodworking and machinist/metalworking areas, but I have to put away woodworking projects to do electronics projects, and vice versa. I have two partially made guitars in progress and a third on the drawing board. And although they won't get done by the end of the summer, I'll at least be able to get them moving again.

Although I can't take my basement on vacation with me, I will definitely use some of that time to expand my musical horizons. Last year I started learning jazz chords and have pushed myself to play more solo lines and melody lines, a tough transition from my strum-and-sing heritage. Of course, I enlist the computer in these efforts and have found eMedia's ([www.emediamusic.com](http://www.emediamusic.com)) Guitar Method and Guitar Songs instructional CD-ROMs very helpful over the years.

### TEACH YOUR CHILDREN WELL

More recently, I've looked at eMedia's Piano and Keyboard Method, which has some very nice features, including the ability to monitor your playing on a MIDI keyboard. Little feedback balloons pop up and tell you, "You held that note too long" or "You played too soon." Mom! Dad! Whatever else you do for your children's musical education, give them keyboard lessons at some early point. Getting both hands involved and playing the bass and treble clefs will give them a solid musical foundation while helping hand-eye coordination. Human teachers are irreplaceable, of course, but with a little help and encouragement from you, Piano and Keyboard Method could teach your kids a lot.

As computer scientist and inventor Alan Kay once said, point of view is worth 50 IQ points, which puts me in the moron brigade when it comes to the latest dance/electronica software. I'm hopelessly mired in the linear world of chords, melodies, choruses, and refrains that make up songs. But when I showed Cakewalk's new Kinetic to multitalented DJ Cyzum ([www.konvocation.com/?s=cyzum](http://www.konvocation.com/?s=cyzum)), he was like a seasoned pilot slipping into the cockpit of a plane he hadn't flown before—a quick orientation, and the next thing I knew, we were flying.

As new beats and sounds swirled around us, Cyzum peppered me with questions I couldn't answer. After we returned safely to earth, his main disappointment was that Kinetic can't function as a MIDI sync slave, although it will work as a ReWire client, which will please Sonar and Cubase users. If it sounds as if I've slipped into an arcane language, I have. Welcome to the burgeoning world of DJs and of the software that gets young bodies writhing at dance clubs all over the world.

### BACK HERE ON MY PLANET

I'm much more comfortable with Guitar Tracks Pro, Cakewalk's 32-track analog recording suite. The latest version (3.0) shares its underlying technology with Cakewalk's highly regarded Sonar, but adds guitar-specific effects, including a guitar amp simulator that can substitute for a whole studio full of classic tube amps. You can record at a full 24 bits/96 kHz for maximum fidelity, and build a track at a time or record multiple tracks if you've got the hardware.

In keeping with modern software and musical styles, you can sample sounds and other music easily. I pulled the opening chords off a Roy Orbison song and looped them. I created a swirling effect with a pan envelope, moving the loop from left to right and back again. Guitar Tracks now supports Groove Clips, which, like Acid Loops, automatically adjust to your tempo.

I inserted a modern drum riff over the reverb-dripping Orbison chords. I sent the loop to a new track, grabbed a guitar, and recorded some riffs over the progression. I made up some dumb lyrics on the spot and recorded a voice track. It sounded pretty bad. I sampled my own voice track and turned it into a series of rhythmic chants. I decided to modify the background so that the Orbison chords and simple drum work would lead off, while the modern drumming would slowly insinuate itself into the music, then ultimately dominate the track.

If I hadn't stopped myself, this column would never have been written. But I gained insight into how sampling and editing can make a new musical statement. I learned enough to be dangerous, if not good. I'll settle for that.

**MORE ON THE WEB:** You can contact Bill Machrone at [Bill\\_Machrone@ziffdavis.com](mailto:Bill_Machrone@ziffdavis.com). For more Extreme Tech columns, go to [www.pcmag.com/machrone](http://www.pcmag.com/machrone).

**Little feedback balloons pop up and tell you, "You held that note too long" or "You played too soon."**



Shuttle XPC G5 8300 System

## Next Generation PC

Introducing the new Shuttle XPC family of computers that offers you high performance and flexibility in a stylish portable unit.

Designed from the ground up to support the newest and fastest technology, Shuttle XPC computers use only the best of breed components. For your home, business or simply for entertainment as a multimedia or gaming PC, these computers scream power and performance like no other, all wrapped in a small form factor that is second to none.

XPC delivers the power and upgradeability of a tower PC in a fraction of the size (7.8 inches Wide by 7.2 inches Height by 11.8 inches Deep).

Visit us at [www.us.shuttle.com/systems](http://www.us.shuttle.com/systems) or call 888-XPC-1818 for more details.



# John C. Dvorak

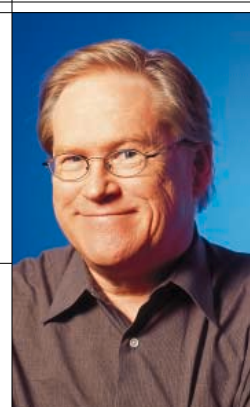

## The Myth of Disruptive Technology

People love a good, unified explanation for the ways things are. One current favorite is the concept of disruptive technology, a coinage and concept put forth by Harvard Business School professor Clayton Christensen and explained in his book *The Innovator's Dilemma*. This guy has so many honors that apparently whatever he says is gospel. The concept of disruptive technology goes to the top of my list as the biggest crock of the new millennium.

A disruptive technology is defined as a low-performance, less expensive technology that enters a heated-up scene where the established technology is outpacing people's ability to adapt to it. The new technology gains a foothold, continues to improve, and then bumps the older, once-better technology into oblivion. Sounds good. The problem is that there is not one example of this ever happening. When boiled down, the notion is essentially a rewrite of the adage Adam Osborne devised to explain the mediocrity of the Osborne 1: "Adequacy is sufficient."

The theory goes on and on, with a seemingly reasoned explanation of how this unfolds. Christensen says the idea stems from his fascination with the collapse of Digital Equipment Corp. Eureka! The microcomputer came along as the cheap, inferior, disruptive technology, eventually supplanting the mini. "Throw out the VAX, Gomez, we've got an Apple II!"

No matter that the CEO of DEC was a screwball who thought advertising was only for proving to your mom that you worked for a real company. No matter that HP, IBM, and Sun continued to prosper selling "minicomputers"—though Sun has a zany CEO too!

The microcomputer was never a "less expensive" and "inferior" replacement for minicomputers. It was a more expensive and superior replacement for calculators and slide rules. It was never used "instead of" a minicomputer (or mainframe for that matter) but "in addition to."

Even the spreadsheet, which is what actually made the desktop computer popular, had no real antecedent except a pad and pen. It didn't replace anything better. It was new.

In the Harvard Business School alumni bulletin highlighting this nonsense, there is a list of supposedly disruptive technologies. Not one is disruptive. At the top of the list are electric cars supplanting gasoline vehicles. On what planet? Internet sales supplanting bookstores. Hmm, Barnes & Noble is

packed with people. Restaurants are being affected by the disruptive technology of grocers' takeout. Are you laughing yet? Motorcycles being affected by the disruptive technology of dirt bikes—does anyone see a pattern here? Is this an April Fools' gag?

James Burke's marvelous PBS TV series *Connections* offers a better explanation for disruption. When there is true disruption, it comes from inventions, regulatory and social change, complementary technologies, coincidence, and demand.

The closest Christensen comes to a real disruptive technology is digital photography. But it was invented in 1972 and has never been "cheaper" than film. The atom bomb is surely disruptive, but neither cheaper nor inferior. The car replaced the horse, but it costs more, and it became a success because of the invention of pavement and the pneumatic tire; asphalt was never cheaper than or inferior to dirt.

There is no such thing as a disruptive technology. There are inventions and new ideas, many of which fail while others succeed. That's it. This concept only services venture capitalists who need a new term for the PowerPoint show to sucker investors.

One could almost make an argument for Linux as a disruptive technology. It's free, so that helps. But what is it disrupting? Microsoft? In 1992, when Linux was invented, Microsoft had about \$2.2 billion in the bank. Now Microsoft has over \$70 billion in the bank and continues to grow. Some disruption.

One problem in our society is the increasing popularity of false-premise concepts that are blindly used for decision making. The amount of money squandered during the dot-com era because of "paradigm shifts" and "new economies" is staggering. People actually believed that all retailing would be online and that all groceries would be delivered to the home as they were in the 1920s, despite changes that make delivery impractical. Who cares about reality? We have a disruptive technology at work!

The concept of disruptive technology is not the only daft idea floating around to be lapped up obediently by the business community. There are others. But the way these dingbat bromides go unchallenged makes you wonder whether anyone can think independently anymore.

**By Prof. Christensen's measure, the Daewoo car is disruptive technology. Are you scared yet, Toyota?**

**MORE ON THE WEB:** Read John C. Dvorak's column every Monday at [www.pcmag.com/dvorak](http://www.pcmag.com/dvorak). You can reach him directly at [pcmag@dvorak.org](mailto:pcmag@dvorak.org).

# It's all about the O.<sup>TM</sup>



Desktops  
save up to 56%

Notebooks  
save up to 46%

Cameras  
save up to 81%

Printers  
save up to 50%

**O**verstock.com<sup>®</sup>  
Your Online Outlet<sup>™</sup>

Overstock.com has books priced below Amazon 99% of the time.

Home & Garden

Jewelry  
& Watches

Sporting Goods  
& Event Tickets

Electronics  
& Computers

Apparel, Shoes  
& Accessories

Worldstock  
Handcrafted

Books, Movies  
CDs & Games

Call 1-800-THE-BIG-O

Overstock.com<sup>®</sup> is a registered trademark of Overstock.com, Inc. All other trademarks are the property of their respective companies and are used only to identify products offered for sale by Overstock.com. These third parties are not affiliated with or sponsors of Overstock.com, Inc.

# Inside Track

**Dongle Mem Dept.:** If you haven't gotten on the USB thumb drive bandwagon, you will. These are the **diminutive** dongles that are loaded with memory that people carry around on their key chains. With capacities as high as 2GB, you can store important files, PowerPoint presentations, contact lists, and even executable software on them.

Now Microsoft and a few others want to **make the devices bootable**. You could then carry around a personal system on a dongle and boot rented or borrowed machines with your own environment. The little Migo device is built with this sort of thinking. In 2003, 23 million of these dongles were sold, and sales are expected to increase to **67 to 120 million** this year.

Already many of the makers are coming up with tricks to make the devices more secure. The newest dongle mem from Crucial Technology has a small file that runs a privacy program, making it impossible to use the device without a password. Eventually I expect to see many of these devices loaded with utility programs.

**The Latest Roadblock to Linux Dept.:** Now Microsoft is enforcing its patent for a long filename version of the FAT (file allocation table) version of its disk data format. Microsoft wants the Linux folks to stop using it. The company might opt for a license, but, golly, because of the GPL, it can't without getting itself into trouble. So stop using it! This situation is being debated everywhere. Since the FAT concept itself actually appeared on IBM **System 1** machines back in the 1970's, it's possible that Microsoft is infringing on something too. This all gets really funny when IBM is involved, since IBM owns so many patents.

I was chatting with a patent lawyer recently, **lamenting the horrid** number of patent suits going around. He said things have actually improved in that regard since the advent of the Internet. "The patents get a lot of publicity and people on the Internet come out of the woodwork citing prior art, killing most lawsuits." We'll see.

**Genuinely Interesting Software Dept.:** If you've been tempted to play with Linux but don't want to go through the process of installation or dual boot or other hassles, then the various versions of Linux Live are for you. These are **preinstalled** and semi-preinstalled versions of the software you **boot from a CD drive** and which run from that drive. The best one I've found is Knoppix Linux (the work of programming legend Klaus Knopper), available for download at [www.knoppix.com](http://www.knoppix.com). You download an ISO image, burn it to a 700MB CD-R, then boot it and go. This version is an **entire disc** of compressed files, and it



**If you're tempted to play with Linux but don't want to go through installation, dual boot, or other hassles, then Live Linux is for you.**

might take all night to download. Included on the disc are games, an office suite, browsers, everything. The experience alone is worth the wait.

I have no idea how many machines this works on, but it booted easily on an Athlon 64 with a lot of new peripherals. With it I could immediately play around with the newest iteration of the KDE **interface**, which is in many ways far more advanced than the Windows XP GUI, with more slick Mac-like features. Outstanding work.

If you want to see some other implementations of the code, check out the Knoppix for Kids software, available at [www.osef.org](http://www.osef.org). Although this derivative iteration isn't quite as clean as Knopper's own, it worked better on the network (though worse on the Internet). It contains some fun kids' games and is also impressive. The best part is that it's **all free** except for the 10-cent CD-R. These and other "live" products will give you a nice feel for what's going on with Linux.

**Genuinely Interesting Software II:** As anyone who reads this column knows, I have a few favorite products. One of them is Disk Jockey, a **modern file manager** program, which helps you organize and view everything on the disk in ways not possible with Windows. The key to its success is its 232 file viewers that can work even with files with no extensions. It lets you look at proprietary-formatted files without having to own the originating software or use converters. And you can cut and paste everything. This is very handy when you are blowing through a lot of files, looking for something. It's been renamed File Viewer and is an absolute steal for \$29.95. Go to [www.clear-simple.com](http://www.clear-simple.com) and get a copy. This is one of the most **satisfying** pieces of software you can own.

**Genuinely Interesting Software III:** Another perennial favorite is Cerious Software's peerless Thumbs-Plus, a tool for photo viewing and editing and for Web-page generation. Features aside, this program has a leg up on the competition for **one main reason**. It can read more photo formats than any other program, including lots of **dead formats** like Kodak's defunct KDC format.

With a lot of competitive album systems out there, Cerious has once again upped the ante. Its upcoming Version 7 Pro will read all the **various RAW file formats**. As more people wisely begin to use RAW, they generally have to convert them to JPEG to get photo programs to catalog the photos. This becomes an **exercise in redundancy**, especially with a RAW-only camera like the Sigma SD-10. Boom. Problem solved. At around \$90, this tool is a must for anyone who is into digital photography. Go to [www.cerious.com](http://www.cerious.com) for ordering information.

THE ONLY MICROSOFT® WINDOWS® - COMPATIBLE 64-BIT PC PROCESSOR AVAILABLE TODAY



ABS® Recommends Microsoft® Windows® XP Professional



## It's What's **Inside** That Counts

- ▶ **Precision Cabling** - All ABS systems come assembled with the utmost care and uses the latest cable management techniques to ensure maximum airflow through the system.
- ▶ **Better Components** - We use only tier-one components that pass stringent quality control tests and benchmarking.
- ▶ **Quality Control** - Every system is hand-assembled by a trained technician and put through a series of burn-in and performance tests to ensure optimal reliability.
- ▶ **ABS Guarantee** - With over 14 years of experience and countless awards, you can count on ABS to deliver the best computing experience at an affordable price.
- ▶ **High Performance** - Dual AMD Opteron™ processor gives you the ability to run both 32- and 64-bit applications simultaneously, so you have the flexibility to effectively manage your business on the schedule you choose. Beyond industry leading performance, serviceability, RAS/reliability, and latency, you have new options in system flexibility.



[www.abspc.com/pm15](http://www.abspc.com/pm15)

**800.876.8088**

- ▶ 1 Year Limited Parts Warranty
- ▶ 30 Days Money Back Guarantee ▶ Hours: Mon-Fri 8:30AM-5:30PM PST
- ▶ 24/7 Technical Support ▶ Lifetime Toll-Free Tech Support

*Always Better Service*

Price, specification, and terms are subject to change without notice. Illustrations may not accurately represent exact configurations priced. ABS® is not responsible for errors in typography and/or photography. 30-day money back guarantee does not include opened software, parts, or special order merchandises. Original shipping and handling fee along with return shipping charge are non-refundable. Products returned after 30 days or in a non-refundable condition are subject to a restocking fee. Onsite service may be provided by contracted third party provider. Technician will be dispatched if necessary following phone support. © 2004 All rights reserved. AMD, the AMD Atom, AMD Arrow logo and combinations thereof are trademarks of Advance Micro Devices.

# Bill Howard



## Geek-Free Home Automation

One of life's ironies is that those of us who can dim the living-room lights and switch the stereo to soft jazz at the press of a single button are probably the geeks who can't get a date and take advantage of the romantic atmosphere.

No less an authority than the *Queer Eye* team recommends dimmed lights everywhere. And that is the core of home automation today: making the remote dimming of lights and switching of appliances work for as many people as possible. New technologies and products over the next year will make automation something to think about even if you don't safety-pin your eyeglasses' hinge.

The old faithful of home automation is X10, which dates to the late 1970s; its products can be found at Radio Shack and [www.x10.com](http://www.x10.com). X10 technology sends power pulses from a switch over your household current to a device. Maybe 95 times out of 100, half a second after you press the button, you get the desired result; say, the porch lights come on. Besides wall plugs for lights (dimnable) and appliances (switchable), there are X10 wall switches and even drapery pulls, thermostats, and lawn-sprinkler switches.

A generation of home AV and security installers have developed enough tweaks and workarounds to raise the X10 success rate to 98 times out of 100—good enough to turn the coffeemaker on but not good enough to turn it off. With PC-based controllers, you can make a PC or a wall switch turn on different lights at different levels.

You may lose one or two cheap X10 devices a year to power surges, so you're better off with Leviton or X10 Pro switches (\$30 to \$50 versus \$10 to \$20), or switches from direct suppliers like Home Automation Inc. (HAI) and Smarthome. Get a whole-house surge suppressor too.

X10 has other drawbacks: Most switches are one-way, so you can't confirm when they're activated. Lights controlled by the cheaper X10 switches have to come on at full brightness before they can be dimmed, which can be a mood-breaker. Most circuits are split between two 120-volt legs, which must be bridged; unless you install a coupler in your circuit breaker box, it may be difficult to signal the X10 devices that are not on the same leg of your home wiring. And X10 is mostly a wired technology.

X10 stalwart Smarthome recently announced a wired and wireless protocol called Insteon, which

works with existing X10 devices. The 900-MHz Insteon wireless adapters also serve as bridges between the two legs of your home wiring. Insteon's drawback is that the wireless isn't standards-based; its ace in the hole is the installed base of X10 fans. Expect Insteon products in 2005, priced about the same as the X10 Pro series.

Another intriguing wireless protocol is Z-Wave, from Copenhagen-based Zensys. Z-Wave is a mesh network; every device that hears the signal passes it along, enabling you to reach throughout the house. The protocol is not standards-based, but Z-Wave has Intel's support (for creating a path to UPnP AV and PC devices). Sylvania sells a starter kit (two modules and a wireless controller) for \$150; HomeSeer makes more sophisticated PC controllers and software.

If the size of its standards committee is an indicator of success, ZigBee, with 62 vendors lined up, could be the next big thing. It's a wireless mesh network that will control dishwashers, furnaces, and washing machines as well as lighting. Something like universal ZigBee (or Insteon, or Z-Wave) could reduce peak demand at power plants on the hottest days if it deferred washing dishes or clothes until late at night. Many analysts are bullish on ZigBee, though that could be because so many cover it. As with Insteon, ZigBee products aren't likely to appear until 2005.

Who will prevail? I suspect the winners will be the ones that Intel and Microsoft embrace. But I'm the last person to predict the future after having been sure X10 would be blown away in the 1990s by something called CeBus (now defunct). ZigBee has the most widespread support, Z-Wave works now, and Insteon can take advantage of the several million X10 homes. For appliance control, you'll likely need a new suite of appliances. Retrofits don't work, except for HVAC systems where the controller is the thermostat.

True home automation is about audio, video, security, and the Internet—as well as romantic lighting. Imagine a \$200 Wi-Fi Pocket PC three years from now—bridged to Insteon, ZigBee, or Z-Wave—controlling your video, music, and lights and even browsing the Web. But even if this automation arrives too late to provide you with a romantic evening, perhaps your teenage children will thank you.

**MORE ON THE WEB:** You can contact Bill Howard directly at [bill\\_howard@ziffdavis.com](mailto:bill_howard@ziffdavis.com). For more On Technology columns, go to [www.pcmag.com/howard](http://www.pcmag.com/howard).

**If the size of its standards committee is an indicator of success, ZigBee, with 62 vendors lined up, could be the next big thing.**

# SOLUTIONS

MAKING TECHNOLOGY WORK FOR YOU

## Degunking Your PC

Here are five ways to rid your PC of digital “gunk” and make it run faster and better. **BY JEFF DUNTEMANN**

Perhaps you’ve wondered, “Is it just me, or is my PC getting slower?” Well, your PC is getting slower, as what we affectionately call *gunk* collects in it. Gunk is data, files, and programs you don’t need, and debris from applications you’ve uninstalled. It’s the entropy of hard drive fragmentation, and chaos in the Windows Reg-

istry from abandoned or corrupted keys. It’s spyware and adware, which beyond compromising your privacy can slow your PC and make it unstable.

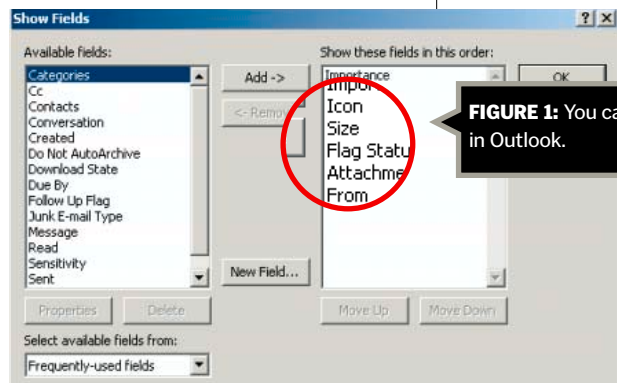

space while sparing the bulk of the messages. Open your *Sent Items* (or *Outbox*) folder, and make sure you have the *Size* column displayed in the message index. In Outlook Express, go to *View | Columns*, and click on *Size*. In Outlook, select *View | Current View | Customize Current View*, and then click on the *Fields* button (Figure 1). With *Size* displayed, click on the *Size* column header to sort the index by message size; then select the

**FIGURE 1:** You can sort messages by size in Outlook.

larger messages that you want to get rid of and delete them. Outlook 2003 contains a very useful *Large Mail* search folder that organizes all your mail by size, making it easy

to spot really big messages.

Outlook also allows you to delete sent messages automatically after a specified period of time. Choose *Tools | Options*. Click on the *Other* tab and then select the *AutoArchive* button. One option lets you per-

manently delete items older than a specified age. For other e-mail clients, you may be able to write a filter that automatically deletes messages after a period of time, but the easiest way may be to sort your messages regularly by

date, highlight messages older than 30 or 60 days, and then delete them as a batch.

manently delete items older than a specified age. For other e-mail clients, you may be able to write a filter that automatically deletes messages after a period of time, but the easiest way may be to sort your messages regularly by

### ✓ PURGE YOUR SENT ITEMS FOLDER

Nearly all e-mail clients keep a copy of every sent message. Though most messages are small, in aggregate their size quickly grows. If you mail large files, you may have many megabytes of them—most of which are stored elsewhere and can be deleted—saved in the *Sent Items* folder. You can quickly free up some serious

date, highlight messages older than 30 or 60 days, and then delete them as a batch.

### ✓ CONSOLIDATE YOUR MEDIA FILES

Nothing fills hard drives faster than digital media. Between digital photos, MP3s, rips of DVDs, and MPEG home movies, even an 80GB disk isn’t so big anymore. Here are steps you can take to keep your media collection from devouring your hard drive.

*Consolidate digital media under one folder.* A logical place is under *My Documents*, where Windows already creates *My Music* and *My Pictures* subdirectories. You can make additional folders for videos, scanned images, and more. Your digital media will be easier to manage if it’s all in one place. Backups will also be easier, because if you just want to protect your data, you need only back up *My Documents*. Should your C: drive, in which Windows places *My Documents*, fill up too quickly, you can move *My Documents* to another drive by right-clicking on *My Documents*, selecting *Properties*, and then entering a new target and clicking on *Move*. All the files will be sent to the new location.

*Purge your digital photo archives of unneeded shots.* Most of us save near-duplicate or bad shots. With higher-end cameras, they can take up several megabytes each. The easiest way to purge them is with a thumbnail viewer; Windows Explorer can act as a primitive one. From your photos directory, select *View | Thumbnails* (Figure 2).

**FIGURE 2:** Use Windows Explorer’s *Thumbnails* view for a quick look at image files.

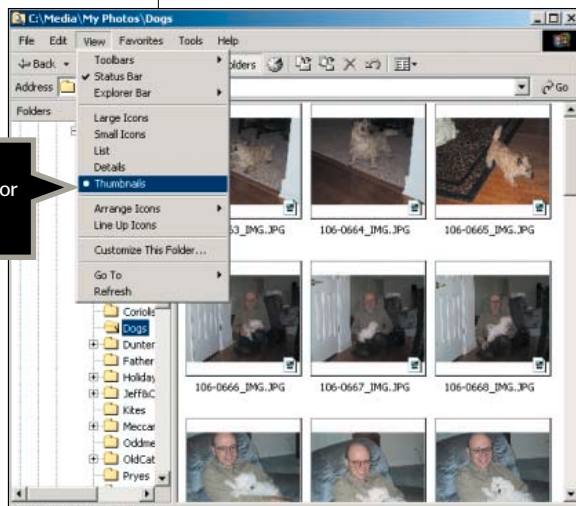



**64** **HARDWARE:**  
Working with RAW  
photos.

**66** **SECURITY  
WATCH:**  
Clean up your  
system.

**68** **ENTERPRISE:**  
Digital asset  
management.

**73** **USER TO USER:**  
Tips and tricks.

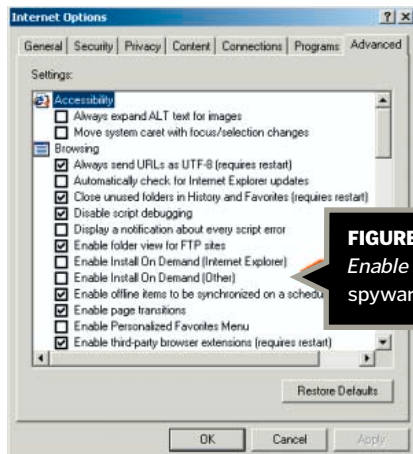

**FIGURE 3:** Uncheck Internet Explorer's two *Enable Install on Demand* options to protect against spyware/adware installation.

Many scanners and digital cameras come with better viewers. ZoomBrowser, which is bundled with Canon digital cameras, and Hemera Graphics Desk, which comes with HP scanners, are both excellent. With many shots visible at once, you can quickly eliminate failed photos and choose the best of several similar shots. If you really don't want to part with them, off-load them to a recordable CD or DVD.

*Purge your digital video clips of bad shots and editing culls.* Digital video files are huge, and raw dumps from a DV recorder contain much useless footage. One approach is that your hard drive is for *processing* videos, and DVD-Rs are for storing them. Try to develop the discipline of editing your video files soon after taking them, then immediately burn them to DVD.

*Purge your music collection of duplicate song files.* If you get your MP3s from various sources, you no doubt have duplicate tracks, especially if you don't use a database to manage your music. The problem stems from a lack of filename conventions. MP3 filenames may begin with a track, album, or artist name. But is "Norwegian Wood" under "The Beatles" or "Beatles, The"? (Or even "The Beetles"? Early on, file traders misspelled artist names to get around blocking systems.) Consider creating a file convention, then editing the names of your music files to follow it. This will turn up all the dupes: Windows won't let you have two files in the same directory with the same name.

You could also sort music files by size. This is best for files obtained online, which

have often been renamed. In Windows Explorer, sort on size; duplicate tracks—which should be the same or very similar in size—will be adjacent and easy to spot.

*Purge old versions of your artwork.* If you create computer drawings or animations, you may have many old versions of

each on disk. Unless an earlier version has an unusual technique, it's mostly wasted space. Force yourself to let them go—or at least archive them to CD or DVD.

#### ✔ GET RID OF SPYWARE AND ADWARE

You should eliminate spyware and adware. Many "free" utilities install a program that transmits details about your Web browsing habits to a server owned by an advertising company (if you're lucky). This process will tailor ads (often pop-ups) to your interests, but it may also bring a torrent of

**FIGURE 4:** Windows Disk Cleanup lets you choose which files to delete.

spam. Such programs are installed with little warning and are hard to remove. They slow your machine, clog your Registry, and may compromise your PC's network machinery.

And that's just the "legitimate" spyware. Related programs (and much worse) are Trojan horses that steal passwords and open network back doors into your PC for malefactors to exploit. They can also turn your PC into a spam proxy without your knowledge.

It's best to avoid installing spyware in the first place. Before you install a "free" program, see if it comes with spyware. Read the licensing agreement carefully. Also, go to Google and type the program's name, followed by "spyware." If spyware is associated with it, you'll find Web sites carrying other users' cries of agony.

Not all spyware is installed with another application; it may come from a Web site. A pop-up may ask if you want to install some-

thing and make it appear that it's a condition of entry. *Don't click on Yes.* Better, use a pop-up stopper utility, or a Web browser like Mozilla Firefox ([www.mozilla.org/products/firefox](http://www.mozilla.org/products/firefox)) with a built-in pop-up stopper. (An upgrade to Internet Explorer in the forthcoming Windows XP Service Pack 2 will also have a built-in blocker.)

If your Web browser (particularly Internet Explorer) isn't configured correctly, some Web sites can install spyware *without asking permission*. IE6 has two options that you *must* disable. (On IE5 and earlier, only the first will be present.) Bring up IE, and select *Tools | Internet Options*. Click on the *Advanced* tab; under *Browsing* is a list of minor topics. The two to uncheck are *Enable Install on Demand (Internet Explorer)*, and *Enable Install on Demand (Other)* (Figure 3). Then click on *OK*.

The most notorious spyware sources are

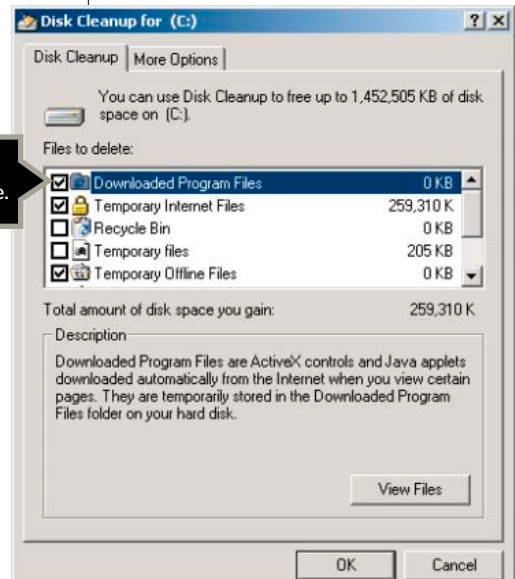

file-sharing utilities, spam-promoted Web sites, and sites offering *sleazeware* such as porn, *warez* (pirated software), and *cracks* (tools to defeat software serial-number registration.) Stay away from these and your defenses won't be tested as often.

Some spyware goes to great lengths to avoid removal. Some nastier items modify the Registry and install small boot-time service routines: If removed, they will re-install themselves from a hidden file!

The best way to get rid of spyware and

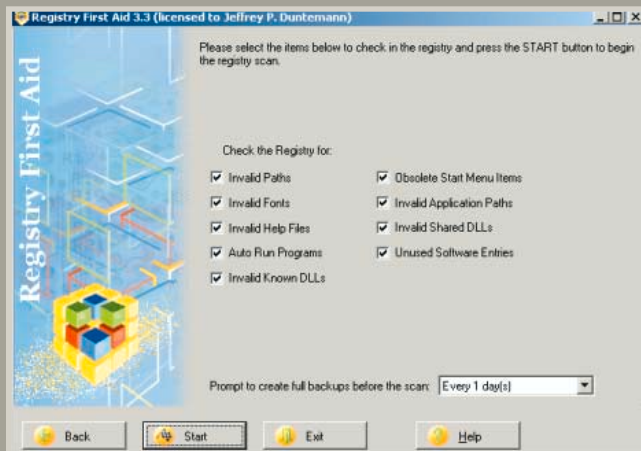

**FIGURE 5:** You can select which potential Registry problems you'd like Registry First Aid to check.

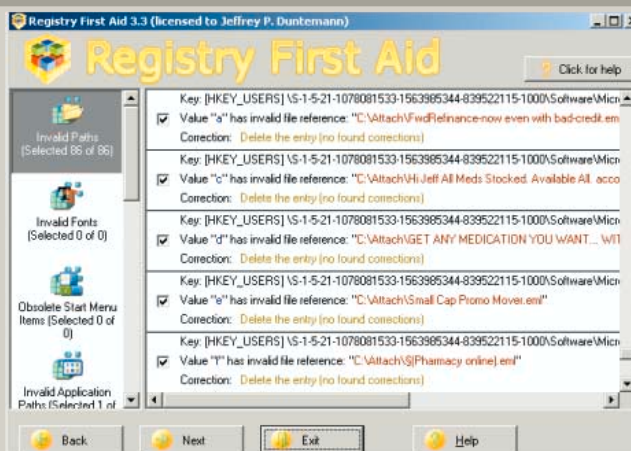

**FIGURE 6:** Registry First Aid displays a list of problem keys that you may want to delete.

adware is to use a utility that's specifically designed for this. Our current favorite is Webroot's Spy Sweeper ([www.pcmag.com/spystoppers](http://www.pcmag.com/spystoppers); \$30 direct), followed closely by the free Spybot Search & Destroy ([www.safer-networking.org](http://www.safer-networking.org); donations are encouraged). In addition to spyware, these programs remove cookies from known spyware and adware companies. Both programs are very easy to use; run them regularly to be sure that nothing sneaks past you.

#### USE WINDOWS DISK CLEANUP AND THEN DEFRAG YOUR HARD DRIVE

Windows Disk Cleanup removes cached and temporary files from your PC. To run it, select *Start | Programs | Accessories | System Tools | Disk Cleanup*. Or you can start it from a button on the main *Properties* display for any nonremovable hard drive. Once you select a drive to clean, Cleanup will determine what it can remove—this may take a while—and then supply a list of file categories (Figure 4). Check the ones that you want to clear, and click on *OK*. If you're unsure about the files in a given category, you can click on the *Files* button to review them, but you're unlikely to find any tagged files worth keeping.

After using Disk Cleanup, defragment your hard drive. Windows 2000 and XP have a built-in defragmenting utility, which is in the same *System Tools* menu as Disk Cleanup. But you can have better, more reliable defragging with Executive Software's Diskeeper 8.0 Professional Edition or Raxco's PerfectDisk 6.0. Both received Editors' Choice in our recent Utility Guide (June 8; or [www.pcmag.com/utilityguide](http://www.pcmag.com/utilityguide)).

Disk defragmentation will reverse a sort of entropy that gradually breaks down the

files stored on your hard drive into small, scattered chunks. When you erase a file, Windows reuses that space. Deleting files opens up free space holes on your drive, which Windows fills as new files are created. Windows knows exactly where each piece of a fragmented file resides, but it has to do a lot more chasing in order to access the scattered fragments. Defragmentation reorganizes your hard drive so that its files are stored as single sequential blocks and thus reading these files can be done as quickly as is physically possible.

#### CLEAN YOUR REGISTRY

Abandoned, incorrect, and corrupted entries in the Windows Registry top our list of gunk. Often people are terrified of trying to clean the Registry, having been told that doing so is about as safe as defusing a nuclear weapon.

There is some truth in this. The Registry is Windows' most vulnerable subsystem, in that relatively small changes *done incorrectly* can render the system unbootable. The Registry is crucial because it is the central database where Windows "remembers" how its thousands of pieces are configured and work together—everything from what color your title bars are to how Windows boots the system and what files it uses when it does.

As you install and uninstall applications, keys are abandoned or invalidated. Many applications store their lists of recently accessed files in the Registry, and as you move files around or swap removable media, keys representing these lists are invalidated and must be built again—adding still more keys to the Registry and slowing your system down. (Windows needs time to determine that a given Registry key is in-

valid, then it must search the Registry again for a valid instance of the same item.)

The safest way to deal with Registry gunk is with one of several excellent third-party Registry cleaners. V Communications' RegistryFixer, part of the company's Fix-It Utilities 5, is our current Editors' Choice in this category, as described in our Utility Guide (June 8, 2004).

Another decent product in the category is Rose City Software's Registry First Aid ([www.rosecitysoftware.com](http://www.rosecitysoftware.com)). It's inexpensive (\$21 direct) and extremely careful with your system. It backs up the Registry before each cleaning run and prompts you to back up your system through Windows Backup if you choose. It deletes only keys it knows it can remove without harming Windows; fortunately, these are the most common ones and the ones most to blame for system slowdowns. Registry First Aid lets you select what sorts of Registry problems to scan for (Figure 5). As the program scans, it builds a list of problem keys (Figure 6). Though the scan can take time, removing the bad keys takes just seconds. The program lets you schedule Registry cleanings regularly.

You may well have performed some of these steps before, but more important than any one technique is cleaning your PC *regularly* so that it lasts longer and runs better. The problem is neither you nor the PC: *It's the gunk*. Clean it out and become a degunking believer.

*Jeff Duntemann is a writer, editor, and industry analyst specializing in system maintenance and wireless networking. He is a cofounder of Paraglyph Press and is a coauthor of Degunking Windows. His latest book is Jeff Duntemann's Wi-Fi Guide.*

# 100% U.S. BASED SERVICE AND SUPPORT

**AT MPC COMPUTERS, WE KEEP OUR TECH SUPPORT CLOSE AT HOME.** At a time when most other PC companies are outsourcing their service and support to other countries, we're keeping our staff right here in the U.S. Our support reps sit right next to our product engineers - not in a different hemisphere. So if you have a problem, your question is answered quickly and accurately with as much technical information as you need. This efficient, U.S.-based service and support demonstrates our commitment to provide with great service and support. **Because at MPC, we're behind you - 100 percent.**

CALL **1-888-564-2766** VISIT [www.mpccorp.com/pcmag414](http://www.mpccorp.com/pcmag414)

©2004 MPC Computers, LLC ("MPC" or "Seller"). MPC is not responsible for omissions or errors in typography or photography. All offers are subject to availability. Prices and specifications may change without notice; prices do not include shipping, handling or applicable taxes, unless specifically required under contract. Seller's return policy does not include return freight and original shipping/handling charges, and a restocking fee may be charged. All return and warranty periods begin from date product is shipped. All sales are controlled by Seller's current terms and conditions of sale and limited warranty, copies of which are available on Seller's website or from its sales representatives. On-site service is provided at sole discretion of MPC. A qualifying diagnostic determination must be made by MPC prior to on-site service (if any). On-site service is provided by a third-party service provider under a separate contract between you and the service provider. Advertised configurations may differ from award-winning configurations. Intel, Intel Inside, Intel Inside logo, Intel Centrino, Intel Centrino logo, Celeron, Intel Xeon, Intel SpeedStep, Itanium, Pentium and Pentium III Xeon are trademarks or registered trademarks of Intel Corporation or its subsidiaries in the United States and other countries. Microsoft and Windows are registered trademarks of Microsoft Corporation. Other product names herein are for identification purposes only and may be trademarks of their respective companies. 1. All hard drive sizes calculated with 1GB equal to 1 billion bytes. 2. MPC 56K modems capable of receiving downloads at up to 56Kbps and sending at up to 31.2Kbps. Due to FCC regulations on power output, receiving speeds are limited to 53Kbps. Actual speeds may vary. 3. 52X = 52X max./17X min. 48X=48X max./17X min. 24X = 24X max./10X min. 8X DVD = 8X max./1X min.

**m**pc<sup>™</sup>  
C O M P U T E R S

## HARDWARE

## Photos in the RAW

The RAW format gives digital photographers unprecedented control in processing images. **BY DAVID CARDINAL**

Many midrange and high-end digital cameras offer the option to save photos in RAW format instead of JPEG. If your camera can do this, you've probably wondered what the RAW format's strengths are and whether you should try it. We'll walk you through how and when to shoot RAW, and how to make the most of your RAW images.

A RAW file is the unprocessed image data as captured by the camera's sensor. It is the photographic equivalent of the image captured by your eyeball before your brain

has had a chance to process it. (See the example of RAW data together with the image of a race car in Figure 1.) Unlike a JPEG, for which your camera itself processes the image data before you ever view it, you must do all the processing of RAW files on your computer. This lets you fully customize settings, including white balance, sharpening, and tone. You can do some exposure correction, but you're still limited to

what was captured in the initial image. RAW files also avoid the artifacts associated with JPEG compression. This isn't much of an issue unless you enlarge your prints to poster size or crop them quite a bit, but for purists, RAW preserves every bit of the original image, acting as a digital negative.

The most common reason to shoot RAW is to handle tricky lighting situations. Getting the color right in a digital image is

hard, and the automatic white balance setting on your camera does not always work. But instead of worrying about setting the white balance, you can make your best guess, shoot in RAW mode, then change the white balance of the images later on the computer.

Figure 2 shows a standard JPEG image of

Half Dome in Yosemite in the upper left and, on the right, the dialog box with options you can set for RAW file conversion using the built-in RAW processor in Adobe Photoshop CS. We've changed the color temperature to make the mountain appear warmer than it did in the shadows when the scene was originally photographed. We were also able to increase the saturation of reds and of the overall image. You can see the resulting image in the lower left.

The disadvantages of RAW files are that you need to process them,

they take more disk space than JPEGs, and not all image browsers let you view them. You can process them with the software provided with your camera, with the built-in RAW file processor in Photoshop CS, or with certain other graphics programs.

For those who miss having a film darkroom, RAW processing gives back to photographers some of the creative control they had when developing film and printing negatives. To extend that analogy, RAW is much like shooting film negatives, while JPEG is closer to shooting slides. With slides, the image is complete the moment you press the shutter, whereas with negative film you need to perform additional steps to create the final printed image.

*David Cardinal is a professional photographer and software author. He publishes the Web site [nikondigital.org](http://nikondigital.org) as an information resource for serious photographers and sells DigitalPro software through [proshooters.com](http://proshooters.com). He is coauthor of The D1 Generation and teaches digital photography throughout the United States.*

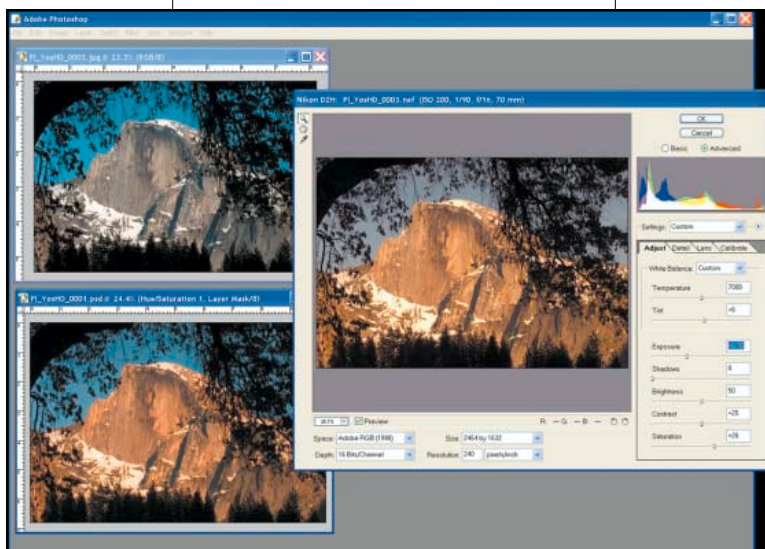
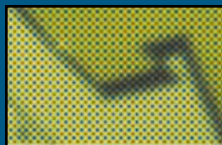

**FIGURE 2:** By shooting RAW, you can use software tools to change the color balance of your image and create warm sunlit tones, even if the image was shot in cool light.

**FIGURE 1:** Digital camera sensors capture only one color per sensor, depending on the tiny filter placed over that sensor. This results in a mosaic of red, green, and blue, as shown in the raw sensor data. The data is then "de-mosaiced" to create a more typical RGB value for each pixel. Finally, the data is adjusted for the contrast (gamma) of your display and for pleasing color.



**Complete car image (processed).**



**Raw sensor data of the number 7 on the car.**



**"Demosaiced" data.**



**Gamma- and color-corrected data.**

MPC recommends Microsoft® Windows® XP Professional.



# It's Hip To Be Square.

## WHAT'S IN WHAT'S OUT

	WHAT'S IN	WHAT'S OUT
MANUFACTURING	Outsourcing Production Overseas	Building PCs In The USA
TECHNICAL SUPPORT	Outsourcing To India	US-Based In-House Staff
PRODUCT EXTENSION	Flat Panel TVs	Focus On Core PC Product Line

OTHER PC COMPANIES

MPC COMPUTERS

At MPC, we know what's trendy in the PC industry. We also know the latest trends don't necessarily make the best solutions for our customers. That's why we engineer and build solid, high-performing PCs, like the TransPort® T2200 featuring Intel® Centrino™ Mobile Technology, right here in the USA. Plus, we back it up with smart, innovative services and in-house technical support.

While we can't brag about being the hippest PC company out there – **we can brag about being the best choice for discerning organizations like yours.**



## TransPort® T2200

- Intel® Centrino™ Mobile Technology
- Microsoft® Windows® XP Professional
- ATI Mobility Radeon 9000 Graphics
- 5.5 lbs and 1.16-inches Thin
- Three-In-One Media Reader
- 802.11 b.g Wireless LAN Integrated
- Biometric Fingerprint Scanner

STARTING AT **\$1849**

CALL 1-888-208-5932 VISIT [www.mpccorp.com/pcmag413](http://www.mpccorp.com/pcmag413)



©2004 MPC Computers, LLC ("MPC" or "Seller"). MPC is not responsible for omissions or errors in typography or photography. All offers are subject to availability. Prices and specifications may change without notice; prices do not include shipping, handling or applicable taxes, unless specifically required under contract. Seller's return policy does not include return freight and original shipping/handling charges, and a restocking fee may be charged. All return and warranty periods begin from date product is shipped. All sales are controlled by Seller's current terms and conditions of sale and limited warranty, copies of which are available on Seller's website or from its sales representatives. On-site service is provided at sole discretion of MPC. A qualifying diagnostic determination must be made by MPC prior to on-site service (if any). On-site service is provided by a third-party service provider under a separate contract between you and the service provider. Advertised configurations may differ from award-winning configurations. Intel, Intel Inside, Intel Inside logo, Intel Centrino, Intel Centrino logo, Celeron, Intel Xeon, Intel Speedstep, Itanium, Pentium and Pentium III Xeon are trademarks or registered trademarks of Intel Corporation or its subsidiaries in the United States and other countries. Microsoft and Windows are registered trademarks of Microsoft Corporation. Other product names herein are for identification purposes only and may be trademarks of their respective companies. 1. All hard drive sizes calculated with 1GB equal to 1 billion bytes. 2. MPC 56K modems capable of receiving downloads at up to 56Kbps and sending at up to 21.2Kbps. Due to FCC regulations on power output, receiving speeds are limited to 53Kbps. Actual speeds may vary. 3. 52X = 52X max./17X min., 48X=48X max./17X min., 24X = 24X max./10X min., 8X DVD = 8X max./1X min.

## SECURITY WATCH

## Disinfecting Your PC

If malware knocks your computer off-line, you can still turn the tables on it. BY LARRY J. SELTZER

**W**hat would you do if your Windows computer suddenly became unresponsive? Or if you could no longer access the Internet?

Viruses and spyware can cause that, even when you're running up-to-date protection against them. Tools aren't perfect, and it's possible that some malware sneaked by.

If you can't get online, you're stuck with the tools built into Windows XP. Your first step is to reboot into Safe Mode. This will prevent much of the software on the system from loading, including whatever might be causing your problem, but will still leave you in a position to correct it. To get into Safe Mode, press F8 as soon as your system beeps on boot-up and select the appropriate option from the menu that appears.

One way to get back to a working state is with System Restore, accessible from *Help and Support* on the *Start* menu. Unless you've told it not to, Windows periodically saves the system state so you can restore it relatively easily. System Restore undoes changes such as program installations, intentional or otherwise, but leaves your documents and most other changes untouched. It's a rather coarse tool, though, and you might want to avoid endangering other changes you've made—or perhaps you've already disabled it.

A better way may be to take a surgical approach to cleaning your Windows start-up. There are a dizzying number of ways, which malware can exploit, to start programs when Windows boots. Windows XP comes with two programs you can use to check what's launching at boot time.

The better program for viewing the information is System Information, located in the System Tools section of the Accessories group on the *Start* menu. Click on

*Software Environment*, then *Startup Programs*. You'll see a list of the programs that start with Windows, including in each case the actual program location and parameters, the user name under which it is run (or an indication that it's run for all users), and the location of the command to start it with Windows—either a Registry key or a folder.

But what are all these programs? If you have another system that can still get online, or a friend to help you over the phone, you can search a database of start-up apps at [www.sysinfo.org](http://www.sysinfo.org). If not, you'll have to guess, based on each program's location and

Name or Startup Item	Status	Command or Data	Description
!NoLoad	U	warecon.exe	Windows - surveillance software that creates records of everything people do on a computer, in, spying or monitoring depending upon how you call it.
!EnterNet	U	EnterNet.exe	Connection manager for the EnterNet ISP. You can also use RASPPPE.
%computername%	?	%computername%	Possibly related to C:\Media Master Control panel!
<executed file name>	X	Reggry32.com	Added as a result of the SOUTHGHOST VIRUS!
<filename>	X	App.exe	Added as a result of the WAKFOW VIRUS! where <filename> is the executed filename
<name>	X	Search.exe	Added as a result of the SDBOT.N VIRUS! where <name> can be random
<random filename>	X	wscpu.exe	Added as a result of an unidentified VIRUS!
<various names>	X	elf.exe	Elf is a hacker program, tied to a trojan server

Sysinfo.org can help you figure out what programs are being loaded at start-up.

the trial and error of removing it.

Unfortunately, System Information is read-only. You can't change the settings. The safest way to proceed is with Windows' System Configuration utility (click on *Start*, select *Run*, then type *msconfig* and press Enter). The narrow window is not resizable, but you can double-click on the column separators to make them fit the width of the data. Click on the *Startup* tab to reveal a list of programs with much of the same information you saw in System Information. Uncheck the programs you want to disable, close the utility, and reboot and those programs will not load.

If this hasn't gotten you back online,

## THE LOOKOUT

## URL PARSING BUG

A bug in fully patched versions of Microsoft Internet Explorer allows violations of the Web browser's security zones, with the result that an unknown malicious site could assume the privileges of more trusted zones.

The same vulnerability could be used for phishing attacks, in which the URL in the address bar appears to be for one site but is in fact a link to a different site. Both of these problems rely on certain misconfigurations of the DNS and Web server on the malicious Web site.

For more information on this, read the complete article at [www.pcmag.com/urlparsingbug](http://www.pcmag.com/urlparsingbug).—LJS

your problems may lie in Internet Explorer. These difficulties are often caused by programs called Browser Helper Objects (BHOs). They plug right into IE, adding toolbars and changing behaviors, often for the worse. Many tools for removing BHOs exist, but without Internet access they're probably not available to you. You do have Windows' Registry Editor, through *Start | Run | regedit*. (The instructions that follow require you to know what you're doing in Regedit. If you don't, you run a serious risk of making things even worse.)

Click on *Start | Run* and type *regedit* to start. Browse on the left side to this key: `HKEY_LOCAL_MACHINE\SOFTWARE\Microsoft\Windows\CurrentVersion\Explorer\Browser Helper Objects`.

The keys that you'll see each have a class ID (usually written as "CLSID"), which is a 128-bit value like {06849E9F-C8D7-4D59-B87D-784B7D6BE0B3}. Each of these keys corresponds to a BHO loaded by Internet Explorer; a feature at [www.sysinfo.org](http://www.sysinfo.org) identifies the BHO that corresponds to each CLSID.

You could prevent Internet Explorer from loading BHOs by deleting them from below the Browser Helper Objects key, but we wouldn't advise it. Just right-click on a given BHO's key, select *Rename*, and add *NOLOAD* or the like to the front of the key. This will stop the BHO from launching and is easily undone if need be. Quit Internet Explorer; when you restart the browser, it should be BHO-free.

These steps may not be a cure-all, but they should be enough to get you back up and running and online.

Larry Seltzer is the editor of eWEEK's online Security Center ([security.eweek.com](http://security.eweek.com)).



## What our users have to say...

*"Visual Communicator helps us to stand out among our competition. It has already helped us capture \$650,000 in new business. Visual Communicator is an amazingly easy-to-use tool that I wouldn't want to live without."*

— Jeff Silva  
Hyatt Regency  
Tampa, FL

## This is what a 10,000% ROI looks like.

Just ask Jeff Silva of the Hyatt Regency in Tampa. His initial investment in Visual Communicator returned over \$650,000 in new business.

Visual Communicator is the proven sales and marketing presentation tool that's already delivering impressive bottom-line results for thousands of other organizations. Our users include corporate giants like Bank of America, Motorola and Volkswagen, but it's also making a big difference in small businesses everywhere.

Visual Communicator is a simple, powerful and affordable solution that allows you to capture attention, establish a personal connection with any audience, and close a sale

like never before. With it you can create high-impact video presentations that better explain your products or services, improve existing presentations, or create personalized sales proposals that deliver results.

It's easy to use and it integrates seamlessly with your existing presentations and content. It even gives you the power to create once, and then instantly share on any Website, across your network, or via CD-ROM and DVD.

Like Jeff, most Visual Communicator users report that it more than pays for itself the first time used.

Jump over to our website to learn more.

Download the free **Visual Communicator** demo today.

**[seriousmagic.com/demo](http://seriousmagic.com/demo)**

Three great versions to choose from

Also available at CDW, PC Connection and Tiger Direct



VideoMaker  
Best Product 2003



BEST OF  
PC & EXP



PC WORLD  
2002



Small product icon

**SERIOUS  
MAGIC**

## ENTERPRISE

# Hungry for Video

Digital asset management helps Scripps Networks deliver television shows on demand. **BY SARAH L. ROBERTS-WITT**

**W**ho among us wouldn't like to remodel a living room for \$1,000 or make crispy duck salad with bitter orange vinaigrette in less than 30 minutes? Any fan of Scripps Networks' collection of home and hospitality cable channels, which includes The Food Network and Home & Garden Television, and which currently has a combined 209 million subscriptions, knows such things are possible.

The problem for most people is finding the time to watch the programs that offer those tips, which is why Scripps now delivers video content to consumers via both the Internet and digital cable. For individuals who subscribe to either service, segments from popular series like *Before and After* and *30-Minute Meals with Rachel Ray* are literally at their fingertips. What makes this possible on the back end is Scripps' digital asset management (DAM) system.

When DAM first surfaced in the mid-1990s, it was primarily a technology for helping media, entertainment, and advertising companies archive and access their video files more effectively. Since then, DAM solutions—like those from Artesia Technologies; INSCI, which now owns DAM pioneer WebWare; and Vignette, which recently acquired MediaBin—have evolved to manage a veritable smorgasbord of digital assets from video to audio to digital photographs and other images. Typically, the files are stored in a single repository and assigned metadata tags that describe the various media types and contents. The files can then be accessed and edited by accompanying browser-based client software.

In addition to the core audience of media companies like Scripps Networks, organizations in finance, retail, and government are now using DAM. This expansion is reflected in growth projections. Research firm IDC expects the DAM market to reach \$1 billion in revenues by 2007, which translates to a compound annual growth rate of 30 percent. And according

to Frost & Sullivan, the DAM market will grow from its current level of \$330 million in software licenses and service revenues to \$2 billion by 2012.

Scripps Networks started working with DAM technology two years ago, when the company decided to overhaul its asset management strategy. "We wanted to be able to reuse all our digital assets for Web sites and on-demand video, and DAM is obviously a critical part of that," says Karen Fitchpatrick, director of media applications for Scripps. After evaluating several products, Fitchpatrick and her team eventually landed on WebWare Active Media.

Today, video from all four channels is sent directly to Scripps' duplication center, where it is automatically encoded and entered into the WebWare system. Using a homegrown content-tracking system, Scripps' employees can access information about video that is currently in production, already archived, or available for video-on-demand or broadband distribution. Available video titles are then distributed to Scripps' cable service and broadband partners, including Comcast, MSN, and Time Warner.

Once the files are distributed, users are

free to view them at leisure. "If you want to see a compilation of segments on bathroom remodeling, you just go to the appropriate digital cable channel, select that topic, and watch away," Fitchpatrick says. "You can pause, fast-forward, or rewind the video; everything is on demand."

Broadband Internet subscribers at either a Comcast or MSN Web site can also view on-demand videos. Some videos are also available on *fineliving.com*, *hgtv.com*, *www.diy.net.com*, and *www.foodnetwork.com*. Today, these are served from a different system, but those files will eventually migrate to WebWare.

Scripps has only scratched the surface of what is possible with its DAM systems, according to Fitchpatrick. On the technical side, the company will continue to develop the content-tracking system so that all of its 900-plus employees can access the Scripps library of digital assets for distribution and promotional purposes. This system, along with capabilities from WebWare, will eventually let Scripps build much more customized on-demand videos that contain bundles of segments from multiple programs. In addition, still photographs will eventually be embedded into the videos to provide step-by-step outlines of any number of home improvement or culinary projects.

All this means that lots more options are on the way for consumers hungry for advice on how to prepare the most succulent meals, pick the best wine, or overhaul the dining room.

## A Smorgasbord of Digital Assets

Scripps Networks' collection of home and hospitality cable channels, including The Food Network and Home & Garden Television, are available on demand to paying subscribers. A digital asset management system from WebWare keeps everything organized. Scripps distributes video titles via its cable service and broadband partners including Comcast, MSN, and Time Warner. The plan is to fold the entire video collection into the system.

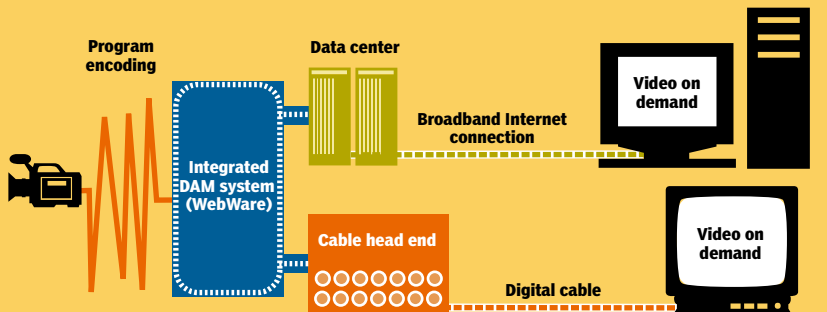





# Driving Business Efficiencies Through Your Imaging & Printing Environment

When it comes to lowering costs, one of the last places that organizations look is their imaging and printing environment. With the right tools in place, significant savings can be realized.

**N**ever has there been more pressure on organizations to improve operational efficiency and productivity. They must do this to be competitive—the global marketplace has never been a tougher place to do business. They must do it to satisfy the demands of emerging regulatory requirements—violators of the Sarbanes-Oxley and Health Insurance Portability and Accountability acts face big fines and even jail sentences. And they must do it simply to lower costs.



The fact is, we have arrived at a time when doing more with less, maximizing potential and minimizing budgets are all part of the same mantra. Yet despite the reasons for change, many C-level executives and top technical managers have often overlooked or not been aware of the increased savings

and decreased total cost of operations that are waiting to be realized from a coherent, well-organized imaging and printing strategy.

Most businesses can save up to 30 percent of document production costs annually if they properly manage their printer, copier, fax and multifunction product fleets.<sup>1</sup>

Research results from International Data Corp. confirm the seriousness of the situation. According to IDC, few companies have assessed their imaging and output infrastructures with the goal of optimizing their hardcopy deployment. So why haven't more corporations tapped into these potential cost savings?

## PARADIGM SHIFT

There are several imaging and printing-related technology trends impacting IT environments today that must be understood and assimilated if companies expect to lower costs and increase productivity. First, e-mail—which has become indispensable to nearly all businesses—means *more* printing, not less. Research shows that printing in organizations increases by up to 40 percent when e-mail applications have been introduced.

Second, even the most basic tenets of printing have undergone significant change. For example, the long-standing print-then-distribute paradigm has been turned on its head. Now, instead of printing documents at central printers or presses and distributing them physically via mail or courier, documents are *distributed electronically* and then *printed locally* at the discretion of the recipient.

A shift away from copying and towards printing has also occurred. Surveys have shown that most copy jobs are relatively small. As a result, users have transitioned from making copies to printing multiple originals on devices closer to them.

These changes mean that the right imaging and output devices must be available to end users in order for them to maximize their productivity levels. However, this is often not the case. Despite the business-critical value of properly organizing these devices, they remain scattered haphazardly throughout organizations where they are frequently underutilized.

Further complicating matters is the astronomical growth rate of all forms of data. This runaway growth is placing a heavy load on imaging and printing environments. So heavy, in fact, that Internet/intranet access and digital convergence are creating a new model for printing and sharing documents. As a result, businesses are moving to different workflow processes through which digital and paper-based content must be integrated and utilized, whenever and wherever needed.

Finally, the highly fragmented profit-and-loss responsibility for various elements in the imaging and output environment may well be standing in the way of optimizing cost structures. Networked devices such as printers and scanners, for example, are typically maintained by IT organizations, while standalone copiers and fax machines that may be located next to the networked devices

## FRAGMENTED RESPONSIBILITY MAY INCREASE COSTS

Part of the reason why imaging and printing costs are higher than need be is fragmented P&L responsibilities. This leads directly to inefficiencies, since no one department can ensure that all devices are optimally deployed.

Direct Costs	Responsibility
<b>Help desk</b>	
Printers, MFPs and digital copiers	IT
Copiers, fax machines	Facilities/operations
<b>Hardware/supplies</b>	
Hardcopy devices, ink/toner	IT, department managers, facilities/operations
<b>Storage (square feet and labor)</b>	
Ink, toner, media; paper document archives	Facilities/operations
Records management	IT and department managers
Outsourced hardcopy jobs	Facilities/operations and department managers
Copy center and mail room	Facilities/operations
Fax	Telecommunications
Indirect and Soft Costs	Responsibility
<b>Employee productivity</b>	
Time lost due to device downtime	IT, department managers, facilities/operations
Time to retrieve or recreate documents (paper or electronic)	Department managers
<b>Unrealized revenue</b>	
Lost documents preclude invoicing	Finance department
<b>Opportunity costs</b>	
Data not in right place at right time	Companywide
<i>Source: IDC, January 2004</i>	

are managed by a separate facilities organization. This fragmented management structure leads directly to inefficiency because no single department can ensure that hardcopy devices are optimally deployed in an organization.

## THE HIGH COST OF DOING NOTHING

Given the enormity of these changes, coupled with tight budgets and lack of centralized control, it's no wonder that many corporations are saddled with outmoded imaging and printing infrastructures that are more of a liability than an asset. Indeed, even if devices are used regularly, many still lack what is now considered to be baseline functionality—such as intelligent networking capabilities that enable both local and remote management. Regardless, companies hang onto these devices because they may not have thought out long-term imaging and printing

strategies, which means there is no compelling reason for replacement.

The costs of maintaining these devices can be prohibitive. For example, excessive support and maintenance expenditures comprise some 60 percent of printer and copier costs, while the other 40 percent are attributable to less obvious costs such as deployment and configuration, updates and upgrades, problem resolution/help desk and software.

How much money is actually at stake? Data from Gartner indicates that the savings opportunity can be substantial—from 10 percent to 30 percent of print spending annually.<sup>2</sup> For example, if a company's annual print spending ranges from \$5 million to \$15 million (typical for a business that generates \$500 million per year in revenues), it could save up to \$4.5 million per year. These savings may be achieved in part by deploying multifunction products.

There is also a substantial opportunity cost associated with settling for the status quo. This cost must be paid as a result of eschewing such productive new technologies as scan-to-function, security, private print, wireless and color.

And those holding out for the advent of the paperless office may have to wait longer than they expected. According to IDC, in 2002, 1.49 trillion document pages were printed annually by U.S. companies and consumers. That number is expected to burgeon to 1.84 trillion pages by 2006.

Inefficient workflows, excessive help-desk calls and runaway energy costs that aging technology may create further contribute to the same, inevitable conclusion: The time is *now* to rethink imaging and printing strategies. Some productivity champion must step up and take action against this disorganization. The cost of doing nothing is just too high.

## MAKING THE MOVE TO MULTIFUNCTION

The tremendous pressure to increase operational efficiency and productivity while reducing costs provides the perfect backdrop for the implementation of a cost-efficient imaging and output strategy. Indeed, there has never been a better time to replace aging and underutilized devices with up-to-date hardware and software. Even if time, dollars and productivity have been lost, the competitive playing field is still relatively level. However, the competitive landscape may soon tilt in favor of those organizations that get their imaging and output acts together first.

Businesses must commit to an imaging and output deployment strategy that relies strongly on a mix of multifunction products—including printing, copying, faxing and scanning capabilities—as well as single-function devices. These MFPs and all other hardcopy devices can be deployed as part of a sensible strategy that consolidates and reduces the number of devices under management. This, in turn, can increase user productivity and create new workflow processes that can be employed to accommodate corporate governance regulations and other infrastructure demands.

MFPs make a great deal of sense for

**‘Organizations are incurring excessive costs for extra footprints, supplies, maintenance and help-desk support because printers, copiers and fax machines are not managed.’—International Data Corporation**

### KEY MFP BENEFITS

- Save time, money and space
- Increase performance
- Improve reliability
- Lower telecommunications costs
- Enhance output quality
- Reduce network traffic and connections

corporations today because they can help to save time, money and space, while enhancing performance, maximizing assets and reducing network connections and traffic. They may also assist companies with lowering telecommunications costs, enhancing output quality and improving reliability. That’s a lot of dollars gained for a relative few invested.

Gartner concurs. “Most enterprises can trim their document output fleet spending by 10 percent to 30 percent while increasing the level of service they provide to users.

“However, they must pay closer attention to their multifunction products and printer fleets, first gathering information about the current state and determining the needs of each organization. Then they

can employ a number of strategies to match the characteristics of the fleet to the needs of the organization. Enterprises that do so can expect large and recurrent savings.”<sup>2</sup>

### SOLUTION: HP

The HP Total Print Management integrated family of hardware, software and services—including leading-edge MFPs—can increase user productivity and reduce the total cost of end-user imaging and printing environments by up to 30 percent annually. As part of this methodology, HP recommends a balanced deployment strategy employing multifunction products, as well as single-function devices when appropriate.

Total Print Management solutions can also improve printing performance while dramatically increasing device utilization and return on investment. To find out how, as well as how to evaluate your current imaging and printing environment to uncover cost savings, see part two of this series, coming in September.

*Part II: How to lower costs and drive efficiencies with HP Total Print Management solutions and multifunction devices.*

### SPECIAL OFFERS FROM HP

There’s never been a better time to find out what an HP MFP can do for your business! Check out these special offers from HP:

- **HP LaserJet 9085mfp and HP Color 9850mfp**  
For a limited time, try one in your office for free.\*
- **HP LaserJet 9055mfp and HP LaserJet 9065mfp**  
Until October 31, 2004, receive HP Digital Sending Software 3.0 Workflow—a \$1,475\*\* value—free with purchase.
- **HP LaserJet 9000mfp**  
Until October 31, 2004, evaluate one for free and save up to \$650 at the time of purchase.\*\*\*

For details, visit [www.hp.com/go/mfppromotions8](http://www.hp.com/go/mfppromotions8) or call 800-888-3127.

\* This offer is based on product availability. Eligibility requirements are at the discretion of the HP partners participating in this program.  
\*\* HP direct price; reseller prices may vary.  
\*\*\* Free evaluation subject to product availability and eligibility requirements are at the discretion of HP and HP partners participating in the program. Mail-in rebate via HP Hot Deals promotion.



**TO DOWNLOAD A FREE WHITE PAPER ON THIS TOPIC, VISIT [WWW.BITPIPE.COM/HP1](http://WWW.BITPIPE.COM/HP1)**

<sup>1</sup> “Small Businesses: Manage Your Printers to Save Money in 2004,” Gartner, March 2, 2004.

<sup>2</sup> “Printer and Copier Fleets: The Gold Mine in the Hallway,” Gartner, August 19, 2003.



## They multifunction, multitask and multi-simplify.

HP multifunctional products can make you more productive—our free MFP strategy guide shows you how. Each of these workhorses can do the job of four machines—printer, copier, scanner and fax or digital sender—in one. Using HP's Digital Sending Software, you can scan and send directly to e-mail or network folders depending on the model. Choose from a wide range of devices to find the one that fits your organization, whether you're a small office or large department. By actively managing your overall fleet, you could save up to 30% on overall operating costs as well as save time on maintenance and supplies management. With our MFPs, you get more than a printer or copier. And with HP and our authorized dealers, you get more than hardware—you get service, support and expert advice. How's that for multifunctional?



### HP LASERJET 4100mfp/4101mfp

Fully integrated printing and copying solution for small workgroups

- Up to 25 ppm print/copy speed (black)
- Print, copy, color scan, digital send and fax (optional with 4100)
- 1,600 sheet maximum input capacity



### HP LASERJET 9000mfp/9000Lmfp

High-performance, versatile printing and copying for large workgroups

- Up to 50 ppm/40 ppm print/copy speed (black)
- Print, copy, color scan, digital send and optional faxing
- Up to 11" x 17" media capable, optional finishing includes multi-position stapling and saddle-stitch booklet production



### HP LASERJET 9055mfp/9065mfp

High-volume, high-performance copying and printing for large departments

- Up to 55 ppm/65 ppm print/copy speed (black)
- Copy, print, color scan, fax and optional digital send
- Optional 4,000-sheet input tray, three-hole punch and cover inserter
- Up to 12" x 18" media capable

**Mail-in rebates available on these two models.\***

Rebates not available in the state of Connecticut.

**FREE Digital Sending Software (HP DSS 3.0 Workflow)**

A free MFP strategy guide and information on current offers are yours for the asking.

CALL

**800-888-3127**

CLICK

**hp.com/go/mfppromotions**

VISIT

**your local HP reseller**



\*Rebate offers good on HP 9000mfp/HP 9000Lmfp purchases made between 5/1/04 and 10/31/04. Rebates are subject to change; check the HP Web site at [www.hp.com/go/hotdeals](http://www.hp.com/go/hotdeals) for most current rebate offers and/or additional rebate offers. ©2004 Hewlett-Packard Development Company, L.P.

# USER TO USER

PC MAGAZINE'S COMMUNITY OF EXPERTS AND READERS

## Use a Formula as a Named Range in Excel

Regarding the article "The Ultimate Sum Formula in Excel" ([www.pcmag.com/article2/0,1759,1401321,00.asp](http://www.pcmag.com/article2/0,1759,1401321,00.asp)): I have a better way than those complex formulas to sum all cells above a certain point. Define a named range as =OFFSET(A\$1, , ROW()-1) and call it A. Do this step while the cursor is in column A. Now define a second range name S as =SUM(A). Enter the simple formula =S anywhere on the current sheet and it will calculate the desired sum of all numbers above.

To make this work for any sheet in the workbook, modify the range name A to read =OFFSET(INDIRECT("R1C", , , ROW()-1)). This formula is slightly longer than the previous one, but it does not require matching the cell address to the current column when creating the formula, and it will work in any sheet of the workbook. Leave the second name unchanged, and the rest of the process is the same.

SHANE DEVENSHIRE

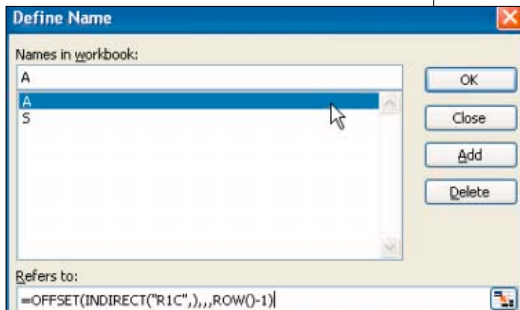

**FIGURE 1:** Surprisingly, you can define a named range with a formula.

Although this technique is not a formula as such, it reveals amazing possibilities. Most of us have probably assumed that named ranges can only refer to—well, ranges—rectangular areas of cells on the worksheet. The idea that a named range can be defined by a formula is surprising.

For those less familiar with using named ranges in general, here are more detailed steps. Select *Insert | Name | Define* from the menu. In the edit box at the top enter A, and in the "Refers to" box at the bottom enter

=OFFSET(INDIRECT("R1C", , , ROW()-1), then click on Add. Enter S and =SUM(A) in the same way, click on Add again, and click on Close. Now you can sum all the numbers above any cell by entering =S. Insert or delete rows at will; the result will always be the sum of all the numbers above the cell.—Neil J. Rubenking

## Merge to E-Mail

I use Microsoft Outlook and maintain a distribution list for a group I belong to so that I can send a weekly newsletter. Lately I've run into a problem, though. My ISP rejects the e-mail going to the list, apparently because of the number of recipients (about 50). According to Comcast, the only way I can get around this is to send to just a few names at a time, which certainly defeats the purpose of a distribution list!

Are there any other workarounds so I don't have to spend an hour typing in a few names at a time?

JIM TRAXLER

In Word 2002 and 2003, the mail-merge feature includes a Merge to E-Mail option. When used this way, it sends individual e-mails to the list of people you select. Word can merge directly from your Outlook Contacts list, but it doesn't handle distribution lists.

Create a new folder within Contacts to hold your list, then copy the members from the list to this folder.

Launch Microsoft Word 2002 or 2003 and select *Tools | Letters and Mailings | Mail Merge* to bring up the mail-merge wizard. Choose *E-mail messages* and click on *Next: Starting document*, then click on *Next: Select recipients*. Click on the option *Select from Outlook contacts* and click on the *Choose Contacts Folder* link. Select the folder you just created and click on *OK*. You'll see a list of recipients; click on *OK*

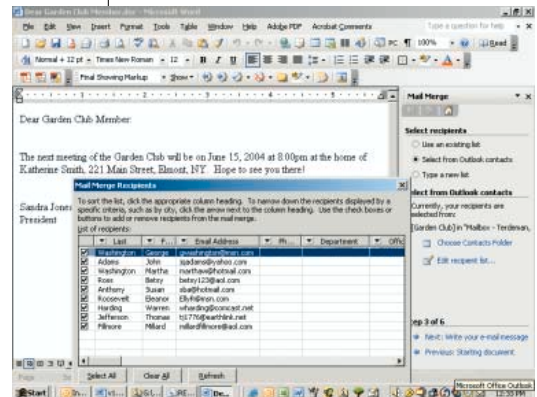

**FIGURE 2:** If your ISP won't let you send e-mail to a large number of recipients at once, you can use Microsoft Word's Merge to E-Mail feature to accomplish the same thing.

again. Proceed through the remaining steps of the wizard, creating your e-mail, possibly adding a personal greeting, and previewing the results. When you're ready, click on the *Electronic Mail* link on the wizard's last page. Word will e-mail a separate message to each recipient.—NJR

## Drive Capacity Discrepancy

I was wondering if you could tell me what's up with hard drive capacity. Mine, for example, was advertised as a 20GB drive, but when I look in Properties, I see only 18.6GB. I've also been shopping around for a new computer for some time, and I have seen a discrepancy of as much as 40GB in the larger drives. I've heard this is because of the operating system, but I can't believe 40GB is taken over by the OS.

JERRY F.

This question comes up fairly frequently, and it doesn't have anything to do with the operating system. The problem is this: In Windows Explorer and other software applications, terms like *megabyte* and *gigabyte* refer to powers of 2, while in the hardware industry they tend to refer to powers of 10. One kilobyte in software is 2 to the 10th power, or 1,024 bytes. In hardware it's 10 to the 3rd power, or 1,000 bytes. The discrepancy mounts as sizes go up, as the table shows.

The idea that a named range can be defined by a formula is surprising.

# E-mail viruses attack through either attachments or HTML code.

## BINARY VS. DECIMAL MEASUREMENT

	Kilobytes	Megabytes	Gigabytes	Terabytes
<b>Binary</b>	1,024	1,048,576	1,073,741,824	1,099,511,627,776
<b>Decimal</b>	1,000	1,000,000	1,000,000,000	1,000,000,000,000
<b>Difference</b>	24	48,576	73,741,824	99,511,627,776
<b>Percent difference</b>	2.34%	4.63%	6.87%	9.05%

Take away 6.87 percent of your drive's stated capacity of 20GB and you get 18.6GB. If you could purchase a 1-terabyte drive, its actual capacity would be short by nearly a tenth of the capacity it would have had if measured in binary terabytes.—*NJR*

### Printing in Black

**I prefer to print some of my photos in black and white, rather than in color, for artistic effect. I was disappointed to find that the photo printer I recently bought prints black-and-white pictures with a distinct brown tinge. Is there any way to correct this?**

**BRIAN C. WILLIAMS**

The reason for the tint is that the black ink in most ink jet printers can't print on glossy paper. So to print black or gray, the printers have to mix cyan, yellow, and magenta inks to create what's called composite black. If the pigments were chosen perfectly and exactly color-balanced, they would mix together to create true grays and black. In the real world, however, composite black often shows an obvious tint—whether blue, green, pink, or brown. Even if you get neutral grays with one set of inks, a tint may show up when you change to a cartridge from a different dye lot.

A few high-end printers come with a utility to balance colors each time you change ink, but if your printer doesn't have such a utility, there's not much you can do. If you don't insist on having glossy prints, you might try printing on matte photo paper, to see whether the printer driver will use black ink instead of composite black on that paper. If that doesn't work, and you're serious about black-and-white photography,

you should consider getting one of the few printers with black or gray inks that work with glossy paper. Canon's i860, for example, uses two black-ink cartridges, one for glossy paper and one for other papers.

—*M. David Stone*

### Reading E-Mail Safely

**I am very concerned about keeping viruses off my system. But I don't really know if the**

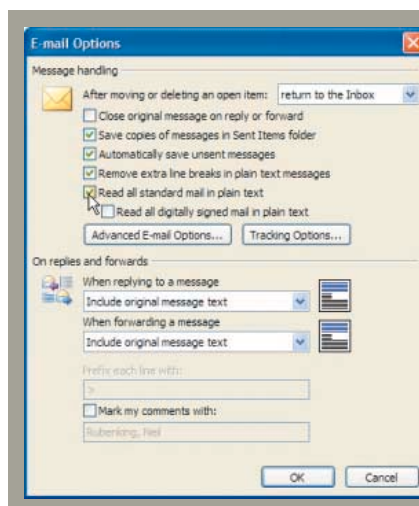

**procedure that I follow to try to avoid them is of any use. To read e-mail messages, I choose the option to view the message source. A window pops up where I can read the message and all the information about it. Is this a safe way to view messages?**

**P. M. TEETERS**

The best way to prevent a virus from infesting your system is to install an antivirus program and keep its virus definitions updated. But even up-to-date antivirus software can miss a fast-spreading attack within the virus's first several hours in the wild, so using additional techniques to prevent infection isn't a bad idea.

You can halt e-mail viruses without digging into the source code. E-mail viruses attack through either attachments or HTML code. Never open any executable e-mail attachment, no matter who sent it. Never open any other attachment unless you

expect it and know the person it comes from. To avoid attacks using HTML code, view your messages as plain text. In Microsoft Outlook 2003, select *Options* from the *Tools* menu, click on the *E-Mail Options* button, and check the box titled *Read all standard mail in plain text*. If you decide later that you want to see a message in its original format, you can click on a button to display it as HTML or as Rich Text.

In Microsoft Outlook Express 6, select *Tools | Options*, click on the *Read* tab, and check the box titled *Read all messages as plain text*. Viewing the actual message is not as easy in OE, as it gets sent along as an HTML attachment. You must launch the attachment to see the message, and OE is

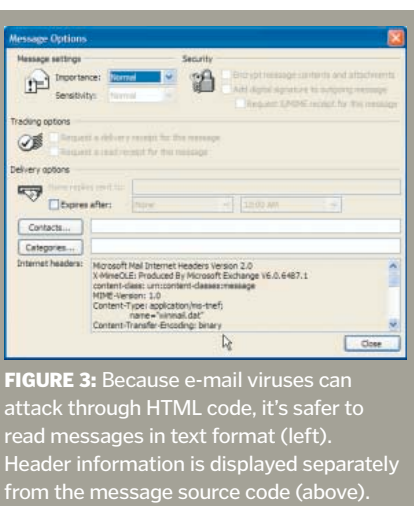

**FIGURE 3:** Because e-mail viruses can attack through HTML code, it's safer to read messages in text format (left). Header information is displayed separately from the message source code (above).

set to block attachments by default. To read the message you will have to turn OE's blocking of attachments off temporarily. Bring up the *Options* dialog again, click on the *Security* tab, and uncheck the box whose text begins *Do not allow attachments....* Be sure to turn that option on again afterward.

Viewing the source code isn't any safer than reading the message as plain text, but if the idea intrigues you, here's how. In Outlook Express 6, right-click on the message subject in the *Inbox*, choose *Properties*, click on the *Details* tab, and click on the *Message Source* button. In Outlook 2003, you can simply right-click in the message body and choose *View Source*. The header data will be displayed separately. To see it, right-click on the message subject in the *Inbox* and choose *Options*.—*NJR*

See more tips online at [www.pcmag.com/usertouser](http://www.pcmag.com/usertouser).

## HOW TO CONTACT US

**E-MAIL** ▶ [pcmsolutions@ziffdavis.com](mailto:pcmsolutions@ziffdavis.com)

**FAX** ▶ 212-503-5799

**MAIL** ▶ User to User, *PC Magazine*, 28 East 28 Street, New York, NY 10016-7940

*If we print your tip, you'll receive a PC Magazine T-shirt. We regret that we cannot answer letters individually.*

# Reduce Your Deployment and Support Costs

MBX is *the* leader for your server and appliance manufacturing needs



## Supermicro 5013G-MB

- Intel® Pentium 4 Processor® at 2.8C GHz
- 1U Rackmount Chassis
- 256MB PC2700 DDR
- Maxtor 80GB 7200rpm Hard Drive
- Dual Onboard Gigabit NIC's
- Includes CDRom, Floppy and Video
- Lifetime toll free tech support
- 3 Year Warranty

**\$899** or lease for **\$30/mo.**



## Or Promote Your Brand

- Same Configuration as Above
- Custom Branded With Your Image
- No Minimum Quantity Needed
- Ideal for ISVs, OEMs or as an Appliance
- Custom OS and Software Install
- Worldwide Deployment and Support

**\$929** or lease for **\$31/mo.**

### Customize Your Systems:

**OS Installs Your Way** - The OS of your choice, your own applications, or no OS at all. Everything configured how you want.

**Packaging and Documentation** - Custom manuals, custom CDs, system guides and custom branded packaging available.

**Drive Imaging Services** - Need a specific install on a quantity of machines? We'll store and load images for your systems.

**Extreme Hardware Flexibility** - Need a specific card or specification? We can meet any special hardware requirements.

**MBX**<sup>TM</sup>  
MOTHERBOARD EXPRESS

**www.mbx.com**  
**1.800.681.8978**

# 17th Annual Reader



# Satis

# SURVEY

**Computers should work right. When they don't, the manufacturer should be there to help. Who's doing a good job, and who isn't? Here's what you told us.** By Cade Metz

**F**ive days after its warranty expired, Jerry Shipley's Toshiba Satellite went on the fritz, its USB port turning on and off at random. "Over and over again, my external keyboard and mouse would just quit working," says the telecom consultant from Frederick, Maryland. When he phoned Toshiba, the company agreed to fix the problem free of charge, despite his expired warranty. Toshiba sent Shipley a packing box with prepaid postage. He

shipped the laptop back to Toshiba, which returned it a few days later, with a new motherboard.

Unfortunately, not only was the USB port still problematic, but the system had become terribly unstable, crashing every few minutes. This time Toshiba refused to help, attributing his problems to a hard drive he'd installed several months before. Shipley took the system to a local repair shop and paid a technician \$95—only to hear that the hard drive was in perfect working order.

Shipley phoned Toshiba again, explaining the latest wrinkle, and, to his surprise, the company did a complete about-face. It didn't just fix his problems, it also mailed him a check for \$95. "I've had my Toshiba notebook for three years now," Shipley says. "I love it, and I'd buy another."

Owning a PC is an up-and-down affair: Sometimes things go well, and sometimes they don't. Even the best machines have problems, and from time to time, even the best manufacturers have trouble fixing them. As Jerry Shipley will tell you, the key is finding a machine whose problems are few and far between—and a manufacturer that can, and will, tackle those problems.

To help you find the most dependable computers and PC manufacturers, we give you our 17th annual Reader Satisfaction Survey, in which Jerry Shipley and more than 8,000 other *PC Magazine* readers describe experiences with the desk-



# faction

tops, notebooks, and servers that they use at home and at work: over 17,000 computers in all.

As you peruse the results, you'll see that no company is beyond reproach. Each is guilty of selling machines that need repair and providing poor technical support at times. The leading vendors—Apple in the desktop and notebook categories, Dell in desktops and servers, and IBM in notebooks—are those that keep criticism to a minimum.

As in past years, respondents rated PCs on several criteria using a 1-to-10 scale, but this year we defined each scale more clearly: 1 to 2 means *poor*, 3 to 4 is *fair*, 5 to 6 *good*, 7 to 8 *very good*, and 9 to 10 *excellent*. We suspected that overall ratings would be in the 6-to-7 range, as few people continue to use a computer they dislike. But we hardly ever hear people tell us how much they love their systems. Apparently, though, you do like them; you really like them. Desktops receive an average “overall rating” score of 7.8, notebooks 8.0, and servers 7.9.

The same enthusiastic attitude doesn't apply to technical support or repair service, however. Desktop and notebook tech support rate 6.3 and 6.1, respectively, while repairs aren't much better, at 6.7 and 6.6.

A growing challenge for vendors is helping customers during virus outbreaks, which were fierce in the 12 months leading up to April, when our survey went out into the field. Six percent of desktop users seeking support say their most recent call was for help recovering from a virus, and this response may be underreported. Users don't always know when viruses are causing their problems; many believe that the problems are defects in their machines or the software shipped with them. Many makers reported a significant increase in support calls in the wake of worms like Blaster and Sasser, which infected millions of systems worldwide. Some makers have struggled to keep pace with the increased volume of support calls.

Aren't manufacturers moving away from phone support in favor of the Internet? Not really. For years, vendors have hyped e-mail, chat, and remote control as the way forward, but most readers still prefer the phone. Over three quarters of respondents needing support used the phone, more than twice as many as used any other means of contact. Respondents are clearly much less happy with Web-based support—consistently the lowest-rated support method for respondents' most

## MORE ON THE WEB

For additional statistics, visit us on the Web at [www.pcmag.com](http://www.pcmag.com)



### Apple: Desktops and Notebooks

In a Windows-dominated world, it's not surprising that people who choose Apple computers do so because they love them. But evangelism alone can't explain the impressive high marks Apple receives again this year. In nearly every aspect, the company scores higher than any other vendor. We prefer more open platforms, but it's hard to argue with this level of satisfaction.

### Dell: Desktops and Servers

People trust Dell, especially when it comes to desktops and servers, two categories in which the brand wins Readers' Choice awards. But declining tech-support scores may foretell troubles ahead.

### IBM: Notebooks

IBM's decision to go against the prevailing trend and provide tech support only through domestic call centers seems to have been an important factor in Big Blue's continued success. No competitor comes close to the company's tech-support ratings.

recent tech-support experiences.

Toshiba has actually discontinued its chat and e-mail support. “When customers get that live voice and are able to actually talk about the issue,” says John Mehrmann, Toshiba's director of channel services, “they end up getting a much higher level of service.”

Unfortunately, phone support is also

SURVEY RESULTS: DESKTOPS

- ▲ Significantly better than average\*
- ▲ Better than average\*\*
- ▼ Worse than average\*\*
- ▼ Significantly worse than average\*

	OVERALL RATING	POOR (1-2.4)	FAIR (2.5-4.4)	GOOD (4.5-6.4)	VERY GOOD (6.5-8.4)	EXCELLENT (8.5-10)	RELIABILITY	TECH SUPPORT	REPAIRS	PERCENT NEEDING REPAIRS	LIKELIHOOD OF RECOMMENDING
<b>ALL DESKTOPS</b>											
<b>ABS (51 responses)</b>	8.1						8.1	—	—	26%	7.9
<b>Apple (165)</b>	8.8 ▲						9.0 ▲	—	—	10% ▲	8.9 ▲
<b>Dell (3,460)</b>	8.1 ▲						8.2 ▲	6.2	6.8	16% ▲	8.4 ▲
<b>eMachines (217)</b>	7.6						7.8	6.4	—	13%	7.6
<b>Gateway (726)</b>	7.5 ▼						7.6 ▼	6.5	5.9 ▼	19%	6.8 ▼
<b>HP/Compaq (1,628)</b>	7.3 ▼						7.4 ▼	6.0 ▼	6.3 ▼	18%	7.1 ▼
<b>IBM (277)</b>	7.1 ▼						7.4 ▼	7.0 ▲	7.9 ▲	18%	6.8 ▼
<b>MPC (125)</b>	7.9						8.2	—	—	18%	7.4
<b>Sony (248)</b>	7.9						8.0	5.7	—	15%	7.9
<b>Clone (594)</b>	8.1 ▲						8.2 ▲	7.2 ▲	7.4 ▲	20%	8.0 ▲
<b>Self-built (917)</b>	8.5 ▲						8.6 ▲	6.9 ▲	7.9 ▲	19%	8.7 ▲
<b>AVERAGE</b>	7.8						8.0	6.3	6.7	17%	7.6
<b>WORK</b>											
<b>Apple (99)</b>	8.6 ▲						8.7 ▲	—	—	13%	8.6 ▲
<b>Dell (2,129)</b>	7.9 ▲						8.1 ▲	6.3 ▼	6.6	16% ▲	8.3 ▲
<b>eMachines (81)</b>	7.4						7.8	—	—	20%	7.7
<b>Gateway (376)</b>	7.2 ▼						7.4 ▼	6.6	6.1	20%	6.6 ▼
<b>HP/Compaq (910)</b>	7.2 ▼						7.4 ▼	6.3	6.4	19%	6.9 ▼
<b>IBM (217)</b>	6.9 ▼						7.2 ▼	6.9	—	18%	6.5 ▼
<b>MPC (64)</b>	7.9						8.3 ▲	—	—	14%	7.4
<b>Sony (90)</b>	7.8						7.9	—	—	18%	8.0 ▲
<b>Clone (324)</b>	8.0 ▲						8.2 ▲	7.2 ▲	7.4 ▲	19%	7.8 ▲
<b>Self-built (360)</b>	8.4 ▲						8.6 ▲	6.9	8.2 ▲	19%	8.8 ▲
<b>AVERAGE</b>	7.6						7.9	6.5	6.4	17%	7.5
<b>HOME</b>											
<b>Apple (88)</b>	9.3 ▲						9.4 ▲	—	—	7% ▲	9.4 ▲
<b>Compaq (337)</b>	7.5 ▼						7.6 ▼	5.5	6.4	16%	7.2 ▼
<b>Dell (1,644)</b>	8.3 ▲						8.4 ▲	5.9	6.8 ▲	16%	8.6 ▲
<b>eMachines (156)</b>	7.8						7.9	—	—	11%	7.7
<b>Gateway (412)</b>	7.8 ▼						7.8 ▼	6.4 ▲	5.8	19% ▼	7.1 ▼
<b>HP (507)</b>	7.4 ▼						7.5 ▼	5.6	6.1	19% ▼	7.4 ▼
<b>IBM (72)</b>	8.1						8.1	—	—	18%	7.9
<b>MPC (77)</b>	8.0						8.2	—	—	20%	7.6
<b>Sony (190)</b>	8.0						8.2	5.9	—	14%	8.0
<b>Clone (357)</b>	8.3 ▲						8.3 ▲	7.3 ▲	7.4 ▲	18%	8.3 ▲
<b>Self-built (668)</b>	8.6 ▲						8.7 ▲	7.1 ▲	7.8 ▲	20% ▼	8.8 ▲
<b>AVERAGE</b>	8.0						8.1	5.8	6.3	16%	7.9
<b>DESKTOPS LESS THAN ONE YEAR OLD</b>											
<b>Dell (1,066)</b>	8.4 ▲						8.5 ▲	6.0	6.6	11%	8.5 ▲
<b>eMachines (97)</b>	8.1						8.2	—	—	9%	8.1
<b>Gateway (88)</b>	8.1						8.2	—	—	15%	7.7
<b>HP/Compaq (436)</b>	7.9 ▼						8.1	5.9	—	11%	7.8
<b>IBM (61)</b>	7.8						8.0	—	—	15%	7.1 ▼
<b>Sony (101)</b>	8.4 ▲						8.5	—	—	10%	8.3 ▲
<b>Clone (233)</b>	8.7 ▲						8.7 ▲	6.9 ▲	—	16%	8.4 ▲
<b>Self-built (386)</b>	9.0 ▲						9.0 ▲	7.1 ▲	8.2 ▲	17% ▼	8.9 ▲
<b>AVERAGE</b>	8.1						8.2	5.9	6.6	12%	7.9

\* At least 2 confidence intervals from the average. \*\* 1 confidence interval from the average. RED denotes Readers' Choice. Except as noted, scores are on a scale of 1 to 10, where 10 is best. A dash indicates that we do not have enough survey data to give the company a score.

**OUR CONTRIBUTORS:** Cade Metz is a senior writer at *PC Magazine*. Sebastian Rupley is a senior editor of the magazine. Executive editor Ben Z. Gottesman and associate editor Sean Carroll were in charge of this story.

among the most expensive support methods. In order to cut costs, many vendors have moved call centers overseas. Big vendors Dell, HP, Gateway, and Toshiba all use at least some foreign call centers, and many readers complain of difficulty communicating with technicians.

Unlike many of its competitors, IBM refuses to use overseas technicians, and its tech-support scores are impressive. Readers give IBM a 7.0 overall score for desktop tech support and a 7.6 for notebooks. They rate IBM support techs' ability to comprehend user problems and to speak in a clear, understandable manner at least a point higher than they do Dell, HP, Sony, and Toshiba techs.

"We really wrestled with the idea of using call centers in India, but all our calls still go through Atlanta," says IBM's Owens. "If you use India, you might save ten cents on the call itself, but you'll blow that away ten times over if the call is handled improperly, if customer satisfaction numbers start to drop."

In order to cut costs, many vendors have moved call centers overseas.

Dell, in particular, may want to re-examine its strategy of outsourcing support. As usual in our survey, the company performs very well in desktops and servers. Dell again tops the server ratings, and only Apple's overall numbers are higher for desktops. But Dell's technical-support numbers have started to drop. They're never better than average on this year's survey, and with servers, they're actually worse than average.

It's too early to tell if cheaper support abroad will win out in the long term. Cutting costs allows companies to undercut competitors on price. But losing customers through frustration with support may ultimately prove to be a costly proposition. How the struggle plays out over the next year will be interesting to see.

# VersaLASER™ The Material Transformation Printer™

*"The VersaLaser is an enabler."*

- Bill Machrone, *PC Magazine*

*"The etching's detail was amazing."*

- Marc Spiwak, *CRN*

*"This is definitely high on my cool products for specialty printing applications."*

- Ira Gold, *Electronic Publishing*



**Harness a laser up to 10,000 times more powerful than the one in your laser printer**

Imagine a desktop computer peripheral for laser cutting, scribing, permanent marking and etching that works with almost any solid material. Cut through plastic, wood, paper, rubber and fabric with the precision only provided by computer controlled, non-contact laser power. Permanently mark, etch or scribe metal, glass, ceramic, stone and other hard materials.

Now, imagine controlling this device as easily as an inkjet printer with your computer, Windows® XP and your favorite software including Microsoft® Word, CorelDRAW!®, Adobe Photoshop®, Adobe Illustrator®, AutoCAD® and more. You can also use input devices such as digital cameras, desktop scanners, drawing tablets and keyboards. VersaLaser does all of this with its unique, patented laser technology.

See materials transformed by VersaLaser at [www.versalaser.com](http://www.versalaser.com).

**UNIVERSAL**  
LASER SYSTEMS INC.

16008 North 81st Street  
Scottsdale, AZ 85260

877-866-9802 or 480-315-3600 • fax: 480-483-5620

Manufactured and protected under one or more of U.S. Patents 5,051,558; 5,661,746; 5,754,575; 5,867,517; 5,881,087; 5,894,493; 5,901,167; 5,982,803; 6,181,719; 6,313,433; 6,342,687; 6,423,925; 6,424,670. Other U.S. and International patents pending. Microsoft and Windows XP are registered trademarks of Microsoft Corporation. Adobe Illustrator and Photoshop are registered trademarks of Adobe Systems, Inc. CorelDRAW is a registered trademark of Corel Corporation. AutoCAD is a registered trademark of Autodesk, Inc.

## INITIAL SETUP EXPERIENCE

Desktops purchased within the past year

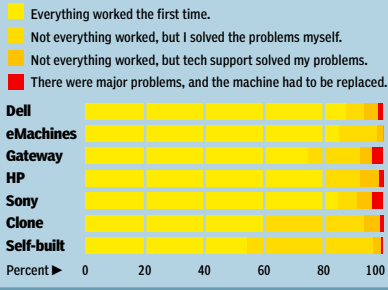

## METHODOLOGY

This survey was in the field from April 27 to May 10, 2004. The results are based on answers from 8,250 *PC Magazine* subscribers. Scores are reported for vendors achieving at least 50 responses.

Note: A statistical t-test was used to calculate significant difference between a vendor's score and the industry average. This objective mathematical formula sometimes presents identical scores with different meaning. Scores are said to be average, better or worse than average, and significantly better or worse than average. Take the example of Dell and ABS's "overall rating" scores for all desktops. While readers give both companies an 8.1 score, the t-test indicates that statistically, Dell's score is significantly better than average, whereas we can report ABS's score to be only average.

## ABS Computer Technologies

ABS was the sleeper in last year's survey, getting a Readers' Choice selection for desktop PCs the first time it qualified for inclusion. This year its desktops (mainly the Awesome, Harmony, and Ultimate Gaming product lines) get mostly high ratings. ABS also makes notebooks, but we didn't receive enough responses to report a score for them.

## SCORING COMMUNICATION SKILLS

Desktops

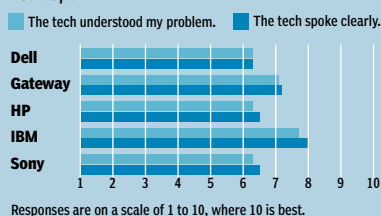

At 8.1, the company's "overall rating" score is slightly above the industry average of 7.8. ABS's score for reliability is also 8.1; the average is 8.0. Respondents are enthusiastic about the ABS brand, and the company's "likelihood of recommending" score of 7.9 is slightly above the average of 7.6.

There are some indications that ABS has quality control issues to resolve, however. Among ABS desktop users, 26 percent report that their machines needed fixes, compared with the average, 17 percent. This gives ABS the worst "percent needing repairs" score of any desktop maker, although it is still within the average range.

We didn't receive enough responses about ABS's tech-support and repair services to give them a score, but we hope readers are having better luck than we did when we tried to contact the company. On one occasion we received busy signals for several hours when trying to reach the company's main operator, tech-support line, and sales line. At other times, we reached the main operator, but only after several minutes on hold.

ABS desktops have one-year parts and lifetime labor warranties unless otherwise specified, and the company offers lifetime toll-free technical support, which some other manufacturers don't.

ABS officials stress that a big part of their approach to customer satisfaction is an ongoing education program for techs. "Our technicians are continuously trained to ensure that they are up-to-date on all of the latest software and hardware," says marketing manager Roger Wong. The company's "overall rating" score in our survey reflects very good satisfaction, but the percentage of units needing repairs is a concern.

—Sebastian Rupley

## Apple Computer



Can all of Apple Computer's survey success be chalked up to fanatical users? Once again, the company turns in a top-notch performance. Apple has enough responses to

qualify for the desktop and notebook categories, and it receives the best "overall rating" score in both: 8.8 in desktops, significantly better than the industry average of 7.8, and 9.0 for notebooks, also significantly better than the 8.0 average. These scores qualify as *excellent* on our 1-to-10 scale, earning the company Readers' Choice awards for both categories.

At 9.0 for desktops and 9.2 for notebooks, Apple's impressive reliability scores are at least a point higher than the industry averages. Nearly all respondents to our survey who supplied quotes about their Apple desktops found them extremely reliable. Compared with other

brands, a much lower percentage of Apple desktop systems needed repairs over the last year.

A great number of the readers who sent in comments regarding Apple said that their older desktop systems were so dependable that they upgraded them instead of buying new systems. "I have a PowerMac 9500 from the mid-1990s," said reader Dallas Blair. "It has been upgraded with USB, FireWire, a PCI IDE card for hard drives, and a faster processor. It's the kind of workhorse that Windows machines can only aspire to."

Apple users are similarly positive about their new Apple notebooks. The company's scores are far better than the competition's in the "overall rating" score,

reliability, and the likelihood of being recommended. (We had fewer than 50 respondents who purchased Apple desktops within the last year, so we couldn't rate the company in this area.)

According to Apple support managers, one reason the company does well in repair and support is that it makes both software and hardware: "Because Apple creates the hardware, software, and operating system, we provide integrated support. Nobody else can offer this kind of end-to-end support." Of course, Macintosh fans can choose machines from only one vendor.

Every Apple system comes with 90 days of toll-free telephone support and a one-

## TOP THREE SYSTEM TYPES PER COMPANY

Desktops purchased within the past year

Dell	Multimedia	34%
	Mainstream	26%
	Corporate	17%
eMachines	Value	47%
	Mainstream	40%
Gateway	Multimedia	38%
	Workstation	36%
	Value	15%
HP	Value	14%
	Multimedia	35%
	Corporate	21%
IBM	Mainstream	21%
	Corporate	49%
	Workstation	16%
	Multimedia	13%
Sony	Small Biz	13%
	Value	13%
	Multimedia	78%
Clone	Media Center	31%
	Mainstream	9%
	Multimedia	52%
Self-built	Mainstream	21%
	Gaming	13%
	Multimedia	61%
Self-built	Gaming	29%
	Mainstream	25%

Multiple choices are allowed, so totals may not equal 100 percent.

**HARDWARE RELIABILITY**

Desktops purchased within the past year

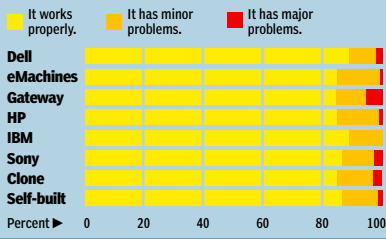

year limited hardware warranty; some other vendors offer lifetime toll-free telephone support. Too few respondents report needing support with or repairs to their Apple computers to rate the company in these areas. Last year, Apple had better-than-average support for its desktops and notebooks, and its notebook repairs were similarly well regarded. (There were also too few respondents to rate desktop repairs in 2003.)

Part of the reason for Apple's high scores could be the user community's long-standing and exceptional brand enthusiasm, but it's hard to argue with such consistently high ratings.—SR

**Dell**



For the 13th time in 14 years, Dell's desktops receive our Readers' Choice. Dell's servers also earn the award, as they have in each of the 4 years that we've asked

about servers. Readers are less enthusiastic about Dell notebooks—particularly its work notebooks, which are too likely to need repairs. Interestingly, however, while the company's notebooks receive a worse-than-average "overall rating" score, Dell's "likelihood of recommending" score in this category trailed only Apple's and IBM's. Readers are also less than enthusiastic about Dell's technical support this year.

In desktops, only Apple fares better. Dell's "overall rating" score, 8.1, is significantly better than average, and its desktops and servers both had among the best reliability scores for all named brands in those categories. Over the past year, Dell has worked to improve system reliability through its new Customer Assurance and Resolution Team Lab, where technicians test Dell machines with third-party hardware and software. "They've tested over 100 products with Dell systems," says

Bobbi Dangerfield, director of U.S. consumer customer experience, "making sure that everything works together when customers receive their machines."

Yet, despite impressive overall ratings, readers have mixed opinions about Dell tech support. When the hard drive died in Robert Glenn's Dell Dimension, for instance, the company sent him a new drive. He had it installed within 48 hours, but dialing the company wasn't as easy as it could have been. "There's a little delay getting service at times on the phone," says the Virginian, "and occasionally, there is some accent problem when you get someone in Pakistan or India."

The company's tech-support scores are slightly lower than average for desktops and statistically worse than average for servers. Support for work desktops rates only a 6.3, compared with an industry average of 6.5. More specifically, Dell

needed repairs, by far the worst rate among work notebook vendors (the next worst is HP's 22 percent). On the home side, the numbers are mostly average, but the work numbers drag down HP's scores in the "all notebooks" category.

Apparently a well-executed repair can go a long way toward making up for high frequency of repairs. Dell's work notebooks actually receive a better-than-average rating for repairs. Despite problems, readers are still very likely to recommend the company's notebooks. Dell's "likelihood of recommending" score, 8.2, is better than the survey average of 8.0. In case it wasn't clear before: People trust Dell.

Dell recently rolled out its Enterprise Command Center, a round-the-clock operation supporting server and storage products. "It looks a lot like a 911 response environment or army command center," says Mark Oldani, director of



Apple's impressive reliability scores were at least a point higher than the industry averages.

users rate company techs' ability to understand problems and speak clearly far below what readers say about techs from IBM and Gateway, the leaders in this area. Some Dell call centers are located abroad. (Among vendors in this report, only IBM and MPC provide entirely domestic support.)

Concerned users have the option of paying extra for Dell's Gold Technical Support, which guarantees that when they call for help, they'll be connected within 2 minutes or less to a high-level technician who's been specifically assigned to them and their business.

Dell's business market woes are worse in our notebook survey, but here the problem is quality. Among work notebook users, Dell's "overall rating" score is worse than average, as is its reliability score. According to readers, a whopping quarter of Dell's business notebooks

customer technical support. "All the people and all the tools and all the processes are in one room—everything needed to make a decision about a customer's system." Unfortunately, the company's tech-support scores show that this investment hasn't yet paid off in the customers' eyes. Dell's servers are at the bottom of the pack for tech support.

The company leads on other measures,

**SOFTWARE RELIABILITY**

Desktops purchased within the past year

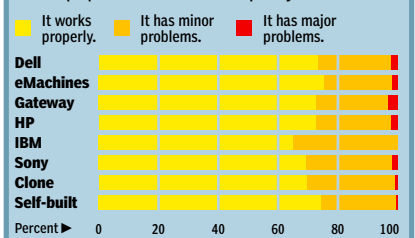

SURVEY RESULTS: NOTEBOOKS

- ▲ Significantly better than average\*
- ▲ Better than average\*\*
- ▼ Worse than average\*\*
- ▼ Significantly worse than average\*

ALL NOTEBOOKS	OVERALL RATING	POOR (1-2.4)	FAIR (2.5-4.4)	GOOD (4.5-6.4)	VERY GOOD (6.5-8.4)	EXCELLENT (8.5-10)	RELIABILITY	TECH SUPPORT	REPAIRS	PERCENT NEEDING REPAIRS	LIKELIHOOD OF RECOMMENDING
<b>Apple (140 responses)</b>	9.0 ▲						9.2 ▲	—	—	17%	9.3 ▲
Dell (1,736)	7.9 ▼						8.0 ▼	6.1	6.9	24% ▼	8.2 ▲
Fujitsu (62)	7.9						8.3	—	—	13%	8.0
Gateway (228)	7.7						7.8 ▼	6.5	—	19%	7.1 ▼
HP/Compaq (952)	7.4 ▼						7.6 ▼	5.9	6.0 ▼	22% ▼	7.3 ▼
IBM (662)	8.1 ▲						8.3 ▲	7.6 ▲	7.3 ▲	20%	8.3 ▲
Sony (265)	7.8						7.9 ▼	4.8 ▼	—	16%	7.7
Toshiba (591)	7.9						8.1	5.8	6.2	17%	8.0
<b>AVERAGE</b>	8.0						8.2	6.1	6.6	19%	8.0
<b>WORK</b>											
Apple (120)	9.0 ▲						9.2 ▲	—	—	19%	9.4 ▲
Dell (1,501)	7.8 ▼						8.0 ▼	6.2	6.9 ▲	25% ▼	8.2 ▲
Fujitsu (51)	7.7						8.2	—	—	12%	7.9
Gateway (192)	7.7 ▼						7.7 ▼	6.8 ▲	—	20%	7.0 ▼
HP/Compaq (778)	7.4 ▼						7.6 ▼	5.9	5.9 ▼	22%	7.4 ▼
IBM (608)	8.1 ▲						8.3 ▲	7.6 ▲	7.3 ▲	21%	8.3 ▲
Sony (211)	7.7						7.9	4.5 ▼	—	16%	7.8
Toshiba (477)	7.9						8.0	5.9	6.2	18%	8.0
<b>AVERAGE</b>	7.9						8.1	6.2	6.6	19%	8.0
<b>HOME</b>											
Compaq (104)	7.1 ▼						7.4 ▼	—	—	24%	6.8 ▼
Dell (298)	8.1						8.2	5.4	6.1	17%	8.2 ▲
HP (108)	7.9						8.0	—	—	20%	7.7
IBM (76)	8.4 ▲						8.5 ▲	—	—	15%	8.7 ▲
Sony (67)	7.9						7.9	—	—	16%	7.5
Toshiba (150)	8.3 ▲						8.5 ▲	—	—	15%	8.2 ▲
<b>AVERAGE</b>	8.0						8.1	5.4	6.1	18%	7.9
<b>NOTEBOOKS LESS THAN ONE YEAR OLD</b>											
Apple (59)	9.1 ▲						9.3 ▲	—	—	14%	9.4 ▲
Dell (616)	8.2 ▼						8.3 ▼	5.8	6.5	15%	8.4
Gateway (83)	8.4						8.6	—	—	12%	8.1
HP/Compaq (380)	7.9 ▼						8.2 ▼	5.8	—	12%	7.9 ▼
IBM (229)	8.5						8.6	7.7 ▲	—	16%	8.5
Sony (81)	8.4						8.4	—	—	9%	8.2
Toshiba (238)	8.3						8.5	5.6	—	14%	8.2
<b>AVERAGE</b>	8.4						8.6	6.2	6.5	13%	8.4

\* At least 2 confidence intervals from the average. \*\* 1 confidence interval from the average. **RED** denotes Readers' Choice. Except as noted, scores are on a scale of 1 to 10, where 10 is best. A dash indicates that we do not have enough survey data to give the company a score.

however: Its "overall rating" score, 8.1, is better than average for servers and significantly better for desktops. Server and desktop scores for the percentage needing repairs are significantly better and better than average, respectively.

People still like their Dells, but there are clearly areas where the company needs to improve. Tune in next year to see what's changed—Dell's support or our readers' minds.—Cade Metz

## eMachines

How can eMachines afford to sell such powerful PCs for as little as \$400 apiece? By keeping repairs and returns to an absolute minimum. Since last spring, the company has paid special attention to quality control, and according to our readers, the hard work has paid off. This year, eMachines' scores show a vast improvement over last year's survey, climbing to

respectable levels in every major desktop category. Among systems less than a year old, eMachines users report the fewest serious problems with initial setup.

eMachines' low-cost PCs are less likely to need repairs than systems from any other vendor save Apple. Whereas only 9 percent of eMachines desktops less than a year old needed repairs, according to readers, the rates of comparably new systems from Dell and Gateway needing repairs were 11 and 15 percent, respectively. Only 1 percent of all eMachines systems needed to be replaced. This translates into a lower cost of doing business, which helps keep prices down.

eMachine's reliability may be a result of the company's decision to place responsibility for quality assurance in the same division as its support services.

eMachine's low-cost PCs are the least likely Windows systems to need repairs.

Mike Zimmerman, the company's senior vice president for customer care services and quality assurance, felt that the people who handle technical-support issues are better prepared than anyone else for improving product reliability and working to avoid such problems. "Typically, quality assurance is handled on the manufacturing or product side of a company," he says. "We're really taking ownership of QA and really looking to reduce the number of problems in the field." The customer care division even has a say in system design and component choice.

eMachines' tech-support score, 6.4, is close to the survey average. It's not quite as impressive as the company's reliability score (7.8), but it still bests the tech-support scores of Dell, HP, and Sony. eMachines has finally included a full one-year warranty with its desktops. It has stopped charging for tech-support calls and offers to service machines over the Web via Windows XP's Remote Assistance tools.

HE DOESN'T PLAY FAIR.



WHY THE HELL SHOULD YOU?

The Klipsch ProMedia Ultra 5.1 gives you the edge. This surround system not only puts you in the middle of the action, but may very well be the difference between victory and certain death. Cues in many of your favorite games, including NOVALOGIC®'s Joint Operations™: Typhoon Rising™ are tested on Klipsch speakers. Developers choose Klipsch because of the Ultra 5.1's uncanny ability to reproduce all the game's detail and dynamics—from the subtle warning of an approaching enemy's footstep to an apocalyptic explosion. Get the Ultimate Sound Advantage.

Get Klipsch. [klipsch.com](http://klipsch.com)

Available at:



ALIENWARE



©2004 Klipsch Audio Technologies. All rights reserved. ©2004 NovaLogic, Inc. NovaLogic and the NovaLogic logo are registered trademarks of NovaLogic, Inc. Joint Operations and Typhoon Rising are trademarks of NovaLogic, Inc. All rights reserved.

Of course, this last development is of little use to people who can't get online—the reason stated for a fifth of the calls to eMachines tech support, according to our readers. For Gateway, the next-worst scorer in this regard, 13 percent of tech-support calls were attributed to this problem.

Now that Gateway owns eMachines, will the brand's service and reliability continue to improve? Or will recent gains be lost as operations are folded into Gateway, many of whose desktop scores are significantly worse than average on this year's survey? Or will the acquisition boost Gateway's

“the best notebook I've ever been issued,” he adds that the case “isn't very sturdy.” Several people in his office have the same LifeBook, and, according to Miller, “a common problem with these machines is that something inside related to the [wireless networking] hardware gets loose and the switch becomes stuck in the *on* or *off* position. Our IT department has made a habit of opening these laptops up and hardwiring the internal wireless NIC to being always on.”

The company's *very good* score of 8.0 for the likelihood of being recom-

just happened when our survey went into the field, however, so we doubt that it had any effect on our results.

This year, readers give Gateway desktops an “overall rating” score of 7.5—in the *very good* range but significantly worse than the survey average. Only HP and IBM scored lower. The company's scores for reliability and likelihood of being recommended are also significantly worse than average, and only ABS PCs needed more repairs. The one ray of light is Gateway's technical-support score in the home desktop category. Although its 6.4 translates to just *good*, that's a higher score than any other brand-name vendor got.

PC Magazine reader Bob Blubaugh, an Indianapolis retiree, had major problems with two different Gateway systems. One wouldn't boot when he first took it out of the box, and the other, after a serious software error, forced him to reformat its hard drive. But he had little trouble reaching Gateway technicians over the phone, and they helped him resolve each problem without much hassle.

On the notebook side of things, only HP got an “overall rating” score worse than Gateway's 7.7. Readers are also less likely to recommend Gateway notebooks than any other brand of mobile system; the company's 7.1 score on this measure is significantly worse than average.

The good news is that among desktops and notebooks less than a year old, Gateway fares much better. On our surveys in these two categories, the company's scores fall within the average range.

The union with eMachines has already meant the consolidation of the two brands' call centers and merged support and quality control operations. Technicians now use chat, e-mail, and Windows XP's Remote Assistance tool to help Gateway customers. In the coming months, Gateway plans to equip its systems with BigFix

## Dells' “likelihood of recommending” scores in desktops and servers are significantly above average.



scores? We won't know until next year's survey, but the initial signs are good. Zimmerman now oversees customer care for both brands. He has already consolidated the companies' call centers, offering chat and e-mail support as well as remote assistance, and he continues to handle quality assurance and support services.—CM

## Fujitsu

Fujitsu qualifies this year in our notebook systems category. Fujitsu users award the company a *very good* “overall rating” score of 7.9 and a *very good* reliability score of 8.3. Tied with IBM, it has the highest reliability score for a Windows-based notebook manufacturer.

In our “percent needing repairs” category, only 13 percent of Fujitsu notebook users say they had to seek fixes—the best score of any notebook maker we evaluated. Reader Marc Miller uses a Fujitsu LifeBook, and although he says it's

mended reflects strong enthusiasm for the Fujitsu brand.

Fujitsu's Executive Mobile Service is responsible for on-the-road satisfaction among business users. If the company determines that immediate repairs are necessary, it sends a trained technician directly to the user's location, anywhere in the continental United States.

On purchase of Fujitsu notebooks, customers can choose a 1-year or 3-year limited warranty. Toll-free technical support is available 24 hours a day, seven days a week.—SR

## Gateway

Gateway's survey scores take a downturn this year, but its merger with eMachines and a recent overhaul of its customer care organization may bode well for the future, given eMachines' dramatic improvement on this year's survey in support and quality assurance. The merger had

### TOP THREE SYSTEM TYPES PER COMPANY

Notebooks purchased within the past year

Apple	Mainstream	51%
	Desktop replacement	41%
	Ultraportable	17%
Dell	Desktop replacement	44%
	Mainstream	36%
	Value	15%
Gateway	Mainstream	41%
	Desktop replacement	39%
	Ultraportable	19%
HP	Mainstream	48%
	Desktop replacement	34%
	Value	18%
IBM	Mainstream	46%
	Corporate	32%
	Desktop replacement	17%
Sony	Desktop replacement	35%
	Ultraportable	35%
	Mainstream	30%
Toshiba	Mainstream	38%
	Desktop replacement	33%
	Value	21%

Multiple choices are allowed, so totals may not equal 100 percent.

### INITIAL SETUP EXPERIENCE

Notebooks purchased within the past year

- Everything worked the first time.
- Not everything worked, but I solved the problems myself.
- Not everything worked, but tech support solved my problems.
- There were major problems, and the machine had to be replaced.

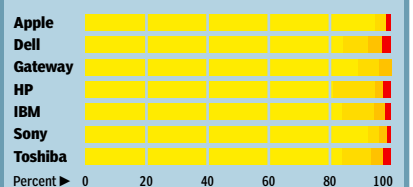



([www.bigfix.com](http://www.bigfix.com))—an application that eMachines owners can already use to get new drivers, security updates, and software patches seamlessly.

We received too few responses from Gateway server owners to include them in this year's server survey results, but the recently merged customer-care operation oversees that side of the business as well. A dedicated network support center handles server customers, and for a period of 30 days after purchase, the company will help you integrate its servers into your existing network. "Think of it as 30 days' worth of consulting services," says Jake Patterson, Gateway's senior director of professional services.

This year, readers didn't rate Gateway all that highly, but given its new customer-care operation, next year may be a different story.—CM

## Hewlett-Packard (including Compaq)

Hewlett-Packard continues to sell both the HP and Compaq brands to the home market, so we evaluate them separately there. For example, HP sells machines labeled HP/Compaq for the business market but sells HP Pavilion and Compaq Presario machines for the home market. Outside the home market, we evaluate the companies together, as HP.

While the "overall rating" scores for HP and Compaq desktops and notebooks qualify as *very good*, their scores in every category are almost all worse than average. The one bright spot is tech support and repairs for servers, where HP outscores Dell. We also see some promising signs in the reader evaluations of new

HP desktop PCs.

HP's tech-support scores of 6.0 for desktops and 5.9 for notebooks, while technically *good*, are near the bottom in both categories. All of these individual ratings help explain the company's significantly worse than average scores for the likelihood of being recommended.

There is little difference between the

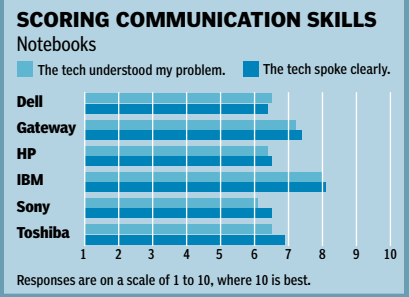

## Do It Yourself

In this year's survey, Apple owners are the happiest with their desktop PCs. But did you notice who's just behind? Not Dell owners. Not Sony buyers. After Apple users, the most satisfied readers built their own machines.

Do-it-yourselfers give their desktop machines an "overall rating" score of 8.5 this year, significantly better than the survey average. They claim their PCs are more reliable than most commercial systems, and they are pleased with technical support and repairs.

But what does this mean exactly? Aren't they providing their own technical support and repairs? Doesn't this smack of self-praise? Can their opinions be trusted?

Such ratings are more telling than you might think. Yes, people who build their own computers may be patting themselves on the back. They do handle most support and repair themselves (though they can phone individual part manufacturers). But you can't ignore the fact that they're happy. The question is, would you be as happy if you built your own machine?

DIYers may be happier because they're more familiar with PC hardware and software. For one, if you're a computer geek, you're much more likely to build your own machine. It also follows that, in building your own machine, you're more likely to *become* a geek. "By seeing exactly where the pieces go and what they do, you have a better understanding of what's gone wrong or what needs upgrading," says Matthew J. Walsh, a 56-year-old

physician who built his own system.

Indeed, most computer DIYers get so proficient that they never make support calls; they *enjoy* handling their own problems. "I've educated myself to the point where I know whether it's a Windows problem or a hardware problem. I know where to find answers on the Web," says Norval Baird, a pilot from Charleston, South Carolina. "I can find answers to problems on my own pretty quickly."

What if a part breaks down entirely? Self-built systems aren't under warranty, but individual parts are. If a hard drive or a motherboard dies, it's just as easy (or hard) to get a replacement free of charge. "I buy all my parts from Newegg.com," says Baird, "and I've only ever had one problem with RMAs [return merchandise authorizations]." And when you've installed the part, replacing it is usually a no-brainer.

The days of saving money building your own system ended with the onset of the price wars and inexpensive machines from Dell, eMachines, Gateway, and others. Unless you're buying closeouts, you're unlikely to beat a system house on price. On the other hand, as we said, the only machines that top DIY desktops in terms of satisfaction are Apples, and

Apple systems aren't cheap.

If you're willing to go through some trial and error, doing it yourself isn't a bad idea. It's not as hard as you might think, you have more control over what components you get, and, once you get the hang of it, you might be better off when things go wrong. Check out our "Build or Buy" story (June 22, page 93) for more information.—Cade Metz



**Become a geek:** The best way to learn about PCs is to build one.

### HARDWARE RELIABILITY

Notebooks purchased within the past year

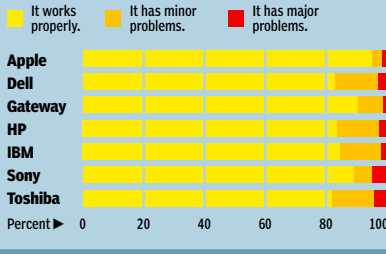

ratings for Compaq and HP's home brands in desktops. But users clearly favor HP's home notebooks over those of its sibling, giving them an "overall rating" score of 7.9, pretty much on a par with the industry average (8.0). Compaq's 7.1 is the worst in the category.

Things may be looking up for HP's desktop business. Although the "overall rating" score of 7.9 for desktops purchased within the past year is worse than average, its scores for reliability, tech support, the per-

centage needing repair, and the likelihood of being recommended are all also in line with industry averages. But the company does score better than Dell in satisfaction with technical support and repair service.

Many readers—especially long-term Compaq server users—told us they felt HP has more to do when it comes to integrating support. "The transition from Compaq to HP has resulted in confusion," said one IT manager who uses Compaq ProLiant servers at a small business.

HP is implementing numerous efforts to improve service and reliability, many on the consumer side. "We will announce several new support programs in August," says Deborah Nelson, vice president of marketing for HP personal systems. Details aren't available, but Nelson says the goal is to recognize that "customers don't just buy a product, they buy a relationship—and we are working hard to improve our customers' total experience with HP at every touch point."

The company has added a toll-free num-

ber across over 16 product lines, including real-time chat with support technicians and e-mail responses within an hour.

These all seem like good steps that could help improve our readers' satisfaction with HP in the coming years.—SR

### IBM



This year, readers leave little doubt that IBM knows how to help customers better than any other manufacturer. In desktops and notebooks, IBM users give the company unrivaled tech support and repairs ratings. On the other hand, while readers give very good marks for reliability to IBM notebooks and decent marks to its servers, they're so disappointed with the reliability of its desktop PCs that IBM's "overall rating" score for desktops is worse than that of any other vendor in our survey.

Unlike many of its competitors, including Dell, Gateway, and Toshiba, IBM doesn't route technical-support calls overseas. Since last summer, all support calls and e-mails have been funneled through a single IBM-operated call center in Atlanta. "If all your technicians are in one place, it's easier to train them, and it's easier to weed out poor call-takers," says Bill Owens, vice president in charge of service and support for IBM's personal computing division. "Consolidating everything in Atlanta makes for better synergy and better overall customer satisfaction."

If Owens's Atlanta-based technicians can't solve your problem, they'll forward you to more experienced technicians in Raleigh, North Carolina, who can bounce issues off the people who actually design IBM's desktops, notebooks, and servers. "These Raleigh technicians literally sit side by side with our product engineering teams," Owens says.

The strategy is paying off. On the desktop part of our survey, IBM's tech-support score, 7.0, is better than average; its repairs score, 7.9, is significantly better than average; and both scores are better than those of any other vendor. Only clones score better in tech support, at 7.2, and only self-built machines tie IBM's repairs score. The company also bests the competition in our notebook category, with a better-than-average repairs score (7.3) and a significantly better-than-average tech-support score (7.6). When it comes

## Although reader scores for Compaq and HP home desktops are very close, users clearly favor HP's notebooks over Compaq's.

centage needing repair, and the likelihood of being recommended are within the average range.

HP support officials note that they're working to diversify the kinds of repair options business hardware users can choose. Customers can return machines to the factory, take care of problems themselves, or get on-site repairs within a specific time, but premium plans cost more.

With an eye to catching problems early, the company has introduced an innovative program where the first 58 users reporting problems with a new product line get replacements, and HP engineers evaluate the sources of the problems. Why 58? HP's statistical analyses showed it to be the optimal number.

Server users give HP a very good "overall rating" score of 7.9—exactly average. Scores for reliability, tech support, the per-

centage needing repair, and the likelihood of being recommended are within the average range. It also has a new, free Web-based support system, Instant Support Professional Edition, for diagnosing and fixing problems. On the consumer side, Nelson points to the Total Care program—introduced in the past year—as making a difference. Total Care offers a portfolio of support services

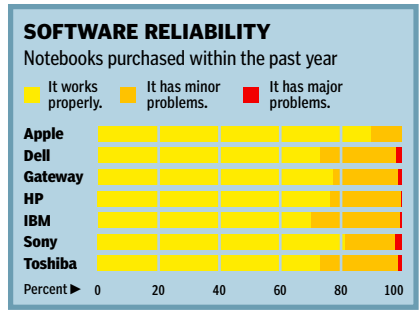

to server scores, IBM registers as respectably average.

IBM also knows how to build a laptop. In the notebook section of our survey, Big Blue's scores for reliability and the likelihood of being recommended are second only to Apple's. This is undoubtedly one of the reasons behind the company's "overall rating" score of a better-than-average 8.1. Again, only Apple's is better. And readers are reasonably impressed with the quality of IBM servers, which receive an "overall rating" score of 7.9 and an 8.2 on reliability. "It's solid as a rock," reader Anthony Kazarian says of his IBM xSeries server. "Everything is designed to keep the unit up and running as long as possible."

Readers are, however, extremely unhappy with the quality of IBM desktops. On our desktop survey, the company receives a reliability score of 7.4—tied for the worst with HP. Presumably because of these reliability problems, IBM's scores for the overall rating and the likelihood of being recommended in this category are also significantly worse than average, at 7.1 and 6.8, respectively.

The good news is that IBM's scores among desktops less than a year old are slightly better. In this subcategory, at 7.1, the company's score for the likelihood of being recommended is still worse than average, but its reliability score, 8.0, is average, and so is 7.8, its "overall rating" score.

Why are IBM's desktop scores so poor? Though readers are quite pleased with the hardware reliability of PCs purchased in the last 12 months, they've had an unusual number of problems with software. Only 65 percent of first-year IBM owners say their system software "works properly." No other vendor drops below 69 percent, and most are in the 70 to 75 percent range. Clearly, IBM has technical support licked, but it still needs to work on reliability when it comes to desktops.—CM

## MPC Computers

Based on the number of respondents, MPC Computers, formerly MicronPC, qualifies in the desktop systems portion of our survey, and it receives a *very good* "overall rating" score of 7.9, close to the industry average.

For reliability, readers give the company's computers an 8.2, which ties for second with Dell among brand-name makers, behind Apple's 9.0. (Self-built machines

## SURVEY RESULTS: SERVERS

	OVERALL RATING	POOR (1-2.4)	FAIR (2.5-4.4)	GOOD (4.5-6.4)	VERY GOOD (6.5-8.4)	EXCELLENT (8.5-10)	RELIABILITY	TECH SUPPORT	REPAIRS	PERCENT NEEDING REPAIRS	LIKELIHOOD OF RECOMMENDING
<b>ALL SERVERS</b>											
Dell (920 responses)	8.1 ▲						8.3	6.8 ▼	7.1	20% ▲	8.4 ▲
HP/Compaq (557)	7.9						8.1	7.3	7.5	26%	7.9
IBM (175)	7.9						8.2	7.7	—	27%	8.0
Sun (53)	7.8						8.2	—	—	38%	7.8
Clone (255)	8.0						8.2	7.9 ▲	7.9	20% ▲	8.1
Self-built (163)	8.2 ▲						8.4	—	—	18% ▲	8.5 ▲
AVERAGE	7.9						8.2	7.2	7.3	28%	8.0
<b>SERVERS LESS THAN ONE YEAR OLD</b>											
Dell (299)	8.1						8.3	6.4	6.9	17%	8.4
HP/Compaq (103)	7.9						8.0	—	—	14%	8.2
Clone (85)	8.2						8.4 ▲	—	—	14%	8.5
Self-built (65)	8.3						8.5 ▲	—	—	14%	8.9 ▲
AVERAGE	8.0						8.1	6.4	6.7	16%	8.3

▲ Significantly better than average\*  
 ▲ Better than average\*\*  
 ▼ Worse than average\*\*  
 ▼ Significantly worse than average\*

\* At least 2 confidence intervals from the average. \*\* 1 confidence interval from the average. RED denotes Readers' Choice. Except as noted, scores are on a scale of 1 to 10, where 10 is best. A dash indicates that we do not have enough survey data to give the company a score.

score 8.6.) Users of MPC desktops at work award them a score of 8.3 for reliability, better than the industry average of 7.9. Eighteen percent of MPC users say their systems needed repairs, in line with the industry average of 17 percent.

We had fewer than 50 MPC users report on needing tech support or repairs, so we couldn't rate the company's service in these areas. MPC officials say that the company pursues customer satisfaction by following an anti-outsourcing model. "While other PC companies are following the trend of outsourcing functions like PC assembly and phone support to foreign countries, MPC has kept these operations in-house," they told us. "We feel that staffing these positions internally enables us to be more responsive and flexible."

The company sells direct and through selected channel partners. Support policies for consumer and commercial/gov-

ernment purchases vary. MPC states explicitly that the company is no longer focused primarily on home users. Company officials told us that MPC instead "focuses specifically on the public sector, including federal government, state, local, and educational organizations." This change may explain some of its poorer scores, such as for the likelihood of being recommended, since home users represented more than half of our MPC responses.—SR

## Sony

Sony's survey results are a good news/bad news story. The company's desktop and notebook PCs, especially its newer systems, are generally well regarded and are less likely to break down than most other brands. But when they do, users are in for arguably the worst support experience in our survey.

"Overall rating" scores for Sony notebooks and desktops are average for this survey, at 7.8 and 7.9, respectively; these qualify as *very good*. An industry-leading 9 percent of owners of notebooks less than a year old report needing repairs, a score only eMachines beat.

Tech support is where Sony falls apart. The tech-support score for all Sony note-

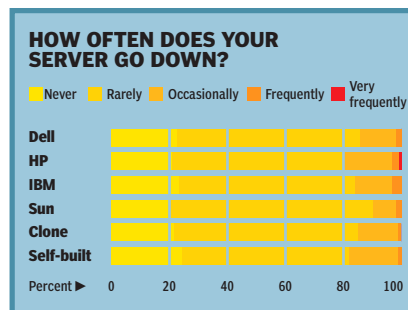

books is 4.8, which barely qualifies as good. It's the worst score in this category. Desktops also get a bottom-of-the-table 5.7. Users of Sony notebooks at work give the company a 4.5 for tech support, the worst score in this category—or in any category in the entire survey.

Things didn't get any better when we looked at the more specific questions about support. The worst areas cited were the company's inability to resolve problems promptly in one call and the relative helpfulness of the service reps.

Steven Nickel, Sony's director of service operations, indicated that some problems may lie with partners helping support Sony products. "As a result of a major initiative to improve our tech-support operations," says Nickel, "we realized that some of our outsource partners were not performing up to our expected standards. We took action to sever relationships with these partners, move more of the support function in-house, and engage with new, more reliable partners whom we are closely monitoring and training to ensure their success." Although this a recent development, Sony says its own internal metrics are showing signs of improvement.

Despite support woes, users of Sony notebooks give the brand a 7.7 score for the likelihood of being recommended—only slightly below the average score, 8.0. Desktop users give it 7.9 in the same category—a bit higher than the average, 7.6.

Sony has recently improved its offerings by eliminating the registration requirement for a one-year warranty and adding the option of extending the warranty to three years. Check back next year to see how readers receive the company's support strategy.—SR

## Sun Microsystems

After receiving a better-than-average score for frequency of failure in the server component of last year's survey, Sun Microsystems' servers draw average Reader Satisfaction Survey scores this year. Users of Sun servers award the company an "overall rating" score of 7.8—the lowest here but still within the average range for this survey.

Sun's score in the "likelihood of recommending" category is 7.8. Although lower than other companies' scores, this is close to the industry average of 8.0, indicating good enthusiasm about the brand.

In our "percent needing repairs" category, Sun falls behind the competition, with 38 percent of Sun server users reporting their machines required repairs. Because of the relatively small number of Sun users in the survey, this is within the average range, but the next-highest rate of repairs needed is IBM's, at 27 percent.

Still, many readers who responded to our survey had good things to say about the reliability of Sun servers running Solaris. For example, one reader said: "Running for over a year without a reboot isn't uncommon. I don't know any Microsoft-powered systems that can do the same."

Sun's support policies vary widely according to server models. As of June, the company introduced Sun Preventive Ser-

repairs. We hope that Toshiba's partnership with UPS, which according to the company has cut repair turnaround times in half, will improve ratings by next year.

Only home users feel that the company's performance is better than average. They give Toshiba better-than-average scores on overall rating and reliability.

Unlike many vendors, Toshiba doesn't offer support via Web chat or even e-mail. Either you use the self-service tools on the Toshiba's Web site or you call its toll-free number. Toshiba previously offered chat and e-mail support but decided that serious problems are typically solved more quickly by phone. "We found that customers were getting into very extended e-mail and chat sessions, and it was very



Readers leave little doubt: IBM knows customer support better than the competition.

vices, which may affect support costs. It is designed "to enable customers to reduce operational risks before they affect uptime," according to Sun tech-support representatives. The subscription-based offering provides over 100 services to IT professionals, and Sun is giving companies that achieve preset computing and uptime goals up to 20 percent off on long-term subscription prices. The goal is "a preemptive service approach to IT problems—avoiding them before they occur."

With respectable scores in all the server categories this year, Sun achieves a reasonable level of satisfaction among its users. Rates of repair are where Sun's scores fall behind those of other server manufacturers.—SR

## Toshiba

In the notebook portion of our survey, readers give the world's largest notebook vendor respectably average ratings, with home users giving the company some above-average scores. But we're somewhat concerned about the company's slightly subpar rating for satisfaction with

difficult for us to get to the root cause of their issues," says John Mehrmann, Toshiba's director of channel services. "Verbal communication is the way to go."

Toshiba routes some U.S. calls to Istanbul. The first three times that reader Rich Pollard called the Toshiba support line, he had trouble conversing with the tech reps he reached. Ultimately, he solved the problems on his own. "They spoke English, but they were extremely difficult to understand," says Pollard, a Toshiba Satellite owner from Omaha, Nebraska. "Though they were extremely conscientious, they couldn't help me out."

When it comes to repairs, however, Toshiba has big plans. In April, the company set up a repair depot *inside* a UPS sorting facility in Lexington, Kentucky. Customers can now mail systems from more than 3,300 UPS storefronts nationwide, and Toshiba can return machines or send replacement parts until 2:00 A.M. They claim that packages sent that late at night reach customers the next day, sometimes as early as 8:30 A.M. We'll find out how customers respond to this plan in next year's survey.—CM ☰



**You can run from your IT department,  
or you can run IT with HelpBox.™**



**HelpBox.™ The other help desk software.**

**The most customizable, money-saving,  
web based help desk you can buy.**

HelpBox, from Layton Technology is software so advanced, and so simple to use, you'll have your operations running smoothly in no time at all! Whether automating daily support tasks, monitoring and managing the delivery of IT services, generating request logs, or tracking troublesome incidents, HelpBox will increase the productivity and effectiveness of your organization. HelpBox offers the same features and quality as that other help desk software, all at a price that won't run away with your budget! So, isn't it time you looked at the other help desk software from the other company?

**Now available for download from the other company at [www.helpbox.com](http://www.helpbox.com)**



1.866.529.8664

All company product names where used are trademarks or registered trademarks of their respective holders. ©Copyright 2004 Layton Technology.

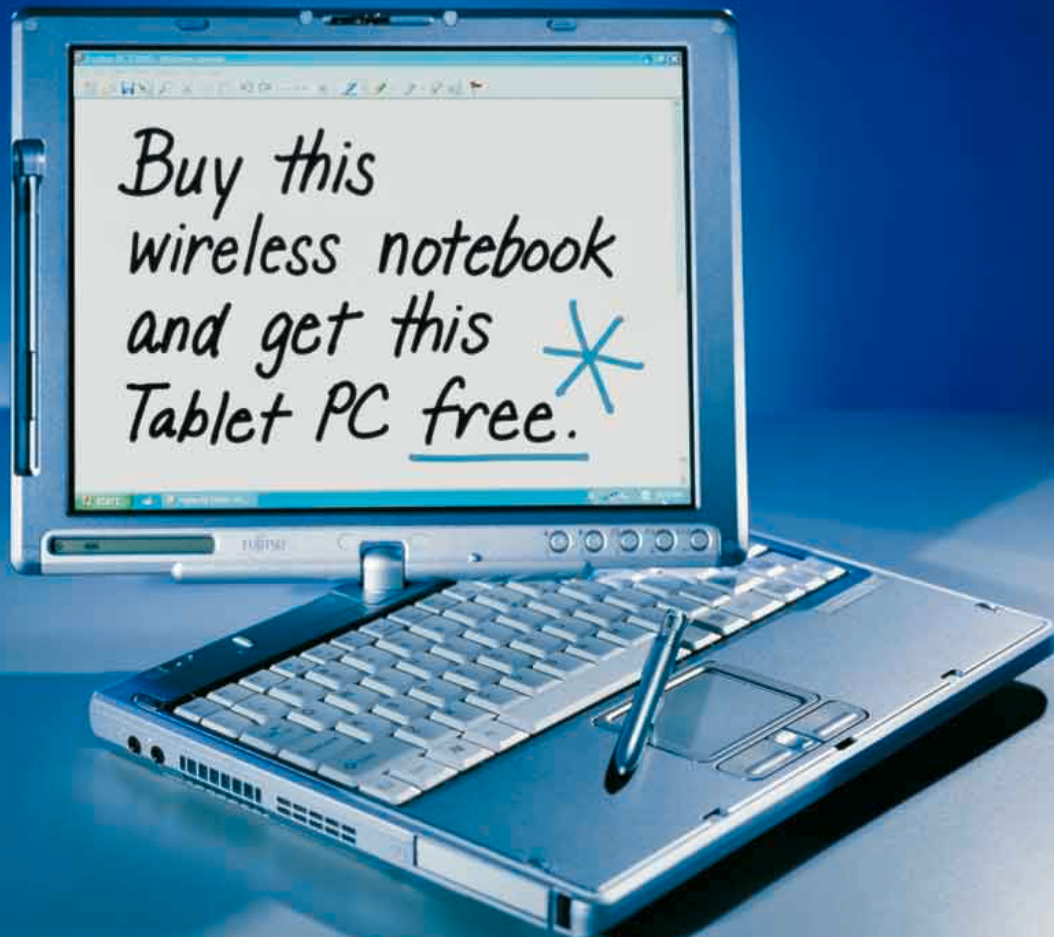

Fujitsu recommends Microsoft® Windows® XP Tablet PC Edition for versatile mobile computing.

**\* Now get Tablet PC and notebook functionality in one system—for one low price.**

Presenting the Fujitsu LifeBook™ T3000 Tablet PC. A unique combination tablet and notebook that gives you the best of both worlds, all for the same price as a standard notebook. The LifeBook T3000 Tablet PC sets a new standard for mobile versatility and convenience. When you need a sleek, high-powered notebook, simply open it up and use its full-size keyboard. Or, when you want to sketch, write, or take notes, pivot and secure the screen and it instantly turns into a Tablet PC. Either way, it offers you built-in wireless access to information anywhere with the latest Intel® Centrino™ Mobile Technology. So stop trying to decide on whether to get a new notebook or Tablet PC. Instead, get the functionality of both, for the price of only one. Go to [us.fujitsu.com/computers](http://us.fujitsu.com/computers) or call **1.800.FUJITSU** today for details.



**FUJITSU**

THE POSSIBILITIES ARE INFINITE



MOBILE  
TECHNOLOGY

# BACK-TO-SCHOOL

**PC MAGAZINE BRINGS YOU  
12 NOTEBOOKS & 9 DESKTOPS THAT WILL  
HELP YOU MAKE THE GRADE THIS FALL.**

# PCs



**Notebooks!**  
Lightweight, easy-to-use...  
take 'em to class!



**Desktops!**  
High power,  
budget  
pricing, and  
entertain-  
ment galore!



By Konstantinos Karagiannis  
Photography by Thom O'Connor

**W**hether you're off to college or your little one is off to grade school, one of the most important supplies to get before autumn is a PC. According to a recent study by the U.S. Department of Education, 99 percent of public schools have some kind of Internet access, meaning that computers are playing a larger role than ever in education—even in its earliest stages. At the other end of the educational spectrum, equipping college students with PCs is a no-brainer, since many colleges offer free broadband both in dorm rooms via Ethernet jacks and around campus via Wi-Fi.

As with buying any PC, its intended use and your budget should dictate your choice. Budget considerations are especially important in light of the current tuition costs at most higher-education institutions.

#### WHO SHOULD GO MOBILE

Notebooks still command a premium, but for college-bound students in particular, they're clearly the preferred PC. They provide the ultimate in flexibility, allowing you to use them in a dorm room or take them to class or the library. And now with wireless Internet connections available on many campuses, a laptop lets you do research under a tree or in a campus common between classes. Consider too that e-book versions of textbooks and online textbook subscriptions are becoming available; your notebook may soon be a 6- or 7-pound replacement for 40 pounds of dead trees in any given semester.

Most college dorm rooms are small, of course, making a laptop the perfect solution to maximize desk space—or to turn your bed into an impromptu work space if you're really cramped. Students com-

muting to school by train or bus will also find that notebooks can really boost productivity, making it possible perhaps to finish your homework on the trip home.

Parents are opting for notebooks for

#### IN THIS STORY

##### NOTEBOOKS

- 93** \$1,000 to \$1,500
- 99** Less than \$1,000
- 94** Notebook Performance Tests
- 98** Notebook Summary of Features

##### DESKTOPS

- 100** Less than \$800
- 100** Desktop Summary of Features
- 101** Dorm Entertainment Systems
- 102** Desktop Performance Tests

- 92** Editors' Choice

- **Notebooks \$1,000 to \$1,500: Apple iBook G4, Velocity Micro NoteMagix B50 Campus Edition**
- **Notebooks less than \$1,000: Averatec AV3225HS**
- **Desktops: eMachines T3092**



The Velocity Micro NoteMagix B50 Campus Edition gets you the best bang for your buck, combining strong performance and high-end components, not to mention reasonable weight and battery life. For a smaller, lighter option, however, the Apple iBook G4 (12-inch) can't be beat—especially for the price. It, too, warrants an Editors' Choice.

Another killer system, the eMachines M6810 gets an honorable mention.

But at 7.7 pounds, it's a stay-in-the-dorm notebook. If you're on a tight budget, the Averatec AV3225HS, at less than \$1,000, is a light, compact notebook with solid performance.

In the desktops category, the eMachines T3092 takes the title; with its DVD burner and 160GB hard drive, the T3092 gets you a lot of computer for little money. Most students will be happy with it as is. Close runners-up are the HP Pavilion a610n for its features, and the iBuyPower Back to School for its raw performance and flashiness.

should keep in mind when you shop that you can reasonably expect only around three years of use. Consider adding an extended warranty for at least that period of time. To reach even the three-year mark, however, you will likely have to replace the battery after about a year and a half (lithium-ion batteries are limited to about 500 recharge cycles).

#### DESKTOPS HAVE BENEFITS, TOO

With desktops you really do get a lot of features for a lot less money than with notebooks. Some budget systems still manage to include plentiful memory, CD burners, big CRT monitors, and large hard drives. And many perform as well as or better than notebooks costing nearly twice as much.

Of course K-to-12 students are a natural market for desktops, as so few of these students have any real need for a portable PC. College students on a really tight budget will be better served with a desktop, too. Furthermore, because most desktops are upgradable, they may even survive a four-year campus stint without becoming totally obsolete.

Some college students who can afford the higher cost of notebooks might still want to consider going with a desktop, particularly if they are computer science majors or engineering students who do heavy graphics work. A \$1,500 desktop for such students will obviously provide that much-needed raw horsepower.

Most students, however, will find that a budget system in the \$800 range, with a 2-GHz Intel or AMD CPU, about 512MB of RAM, and an 80GB hard drive will serve them well for a while. Unlike notebooks, desktops allow you to go cheap on a couple of things now and upgrade later.

On the following pages, we look at notebooks that meet two price classes—nine in the \$1,000-to-\$1,500 range and three for less than \$1,000. And for desktops, we review six systems below the \$800 price point, monitors included. And for college students who want to make a desktop PC their primary entertainment center, see our sidebar "Dorm Entertainment Systems." Considering that you won't have to spring for a TV, DVD player, and stereo—or make room for them—the slightly higher prices of multimedia PCs can still make them worthwhile.

some younger students too. Notebook sales for kids in kindergarten through grade 12 were up 37.3 percent in 2002, according to the latest study by research firm Gartner. That's almost the same as the percentage increase in college notebook sales, which Gartner found to be up 38 percent in the same year. Still, we don't think notebooks make sense for most families with kids in primary education. Grade school homework is done mostly at home anyway, and a PC used for this purpose might as well be the shared family PC.

College students shopping for a notebook should consider what kind of infrastructure their campuses have. A notebook that doesn't have Gigabit Ethernet, for instance, may work just fine if the school supports only 10/100 (Fast Ethernet) anyway. Also, a school may have specific system and software requirements, so it's good to find that out before buying.

Perhaps the most important thing to understand when shopping for a notebook, though, is that this is a notebook! Even though you can add a monitor and input devices for desktop use, you're married to the machine's weight, keyboard, and screen size. For students expecting to tote their notebooks around on a daily basis, systems of roughly 6 pounds or less and more than 3 hours of battery life make sense. Those planning to carry their note-

books only occasionally can save some money by going with a desktop replacement machine in the 7-pound-or-heavier range. These heftier systems often have a fuller set of features, because they don't skimp to save on space and weight.

Get the best processor you can afford, but don't count on much upgradability. Adding memory later is doable, but replacing a hard drive can be pricey. Having a built-in CD burner is becoming standard, and that will at least enable you to off-load some files to CD for long-term storage.

In the less-than-\$1,000 range, you

## WHICH TO BUY?

### Notebooks

- Are great for note taking in class or the library.
- Fit on even the tiniest desks.
- Can help commuting students get homework done while in transit.

### Desktops

- Offer the greatest horsepower for the buck.
- Can be easily shared with the whole family.
- Are easy to upgrade and repair.

**MORE ON THE WEB** Point your browser to [www.pcmag.com](http://www.pcmag.com) for more reviews of notebooks and desktops that could end up on your short list of school supplies this fall.

Our contributors: Omar Cintron, Joseph A. Guilbeau IV, Lawrence Judd, William Pagan, Alphonse Ragusa, and Charles Rodriguez are staff members of *PC Magazine*. Senior editor Konstantinos Karagiannis, associate editor Jenn DeFeo, and PC Magazine Labs lead analysts Cisco Cheng and Joel Santo Domingo were in charge of this story.



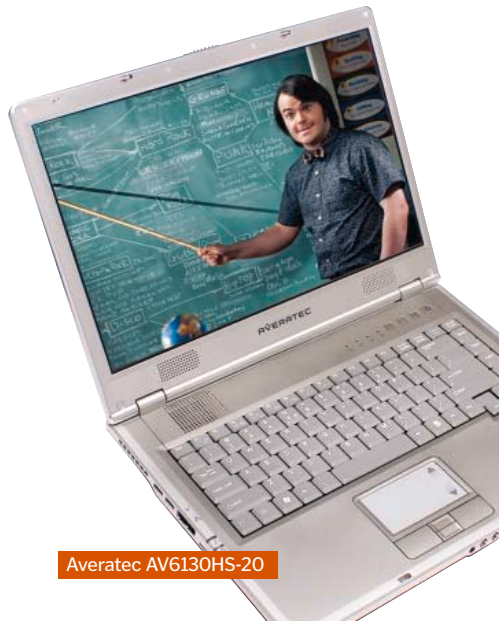

Averatec AV6130HS-20



Dell Inspiron 600m



Apple iBook G4

## NOTEBOOKS [\$1,000 TO \$1,500]

### Apple iBook G4 (12-inch)

\$1,099 direct. Apple Computer Inc., [www.apple.com/education](http://www.apple.com/education). ●●●●○



The cool factor of this notebook has withstood the test of time. It's still very sleek and very small, weighing just 4.9 pounds with a 12-inch screen; you'll barely notice it in your backpack. The price, too, is hard to resist (\$1,099). College students and K-to-12 teachers get an even better deal with Apple's Education Discount: \$999. For all these reasons, it earns an Editors' Choice.

What impresses us most is the iBook's improved battery life. The system played the entire *Titanic* DVD (3 hours and 15 minutes) yet still had 12 percent of its battery life remaining. This is the most we've seen in any iBook or PowerBook to date. The ATI Mobility Radeon 9200 graphics card will get you through your DVD collection but don't expect to do anything 3D intensive. To get the most from the iBook, we suggest upgrading the memory to 512MB (\$100). Mac OS X 10.3 Panther is included, as are QuickTime, iMovie, iTunes, iPhoto, iDVD, AppleWorks, and Mac OS X Mail.

The system comes with two USB ports, one FireWire 400 port, a Video Out port, an Ethernet port, and a modem port. The DVD/CD-RW combo drive is now standard in iBooks, and the system also comes with the built-in Apple AirPort Extreme 802.11g wireless solution. In testing, the Apple's 802.11g signal was strong through 160 feet.

If mobility is at the top of your list, the wee iBook is the perfect notebook to tote. And its battery will get you through class, and then some.—Cisco Cheng

### Averatec AV6130HS-20

\$1,449 list. Averatec Inc., [www.averatec.com](http://www.averatec.com). ●●●●○

Little-known vendor Averatec has proven to be a winner in the budget market. The Averatec AV3225HS notebook won an Editors' Choice in our First Looks budget notebook roundup (June 8). In the back-to-school market, however, the Averatec AV6130HS-20 just missed the mark. The cool features are certainly there, but poor battery life and wireless range keep us from recommending it for the classroom.

Like other notebooks, the AV6130HS-20 emulates Apple's PowerBook design. Its crisp 15.4-inch wide-screen display can handle 3D graphics and DVD movies smoothly. The S/PDIF (Sony/Philips Digital Interface) port—increasingly popular for outputting digital audio—is in the front. We were impressed with the inclusion of a DVD±RW drive; the only other notebook in this roundup to include one is the Toshiba Satellite A45-S250. We also appreciate the Secure Digital slot, which always comes in handy.

Despite all these nice features, however, this notebook's weak spot is its portability. Its battery didn't last even 2 hours on our tests. Carrying the 1.8-pound power adapter with you isn't ideal either, since the notebook itself already weighs 7.7 pounds.

As for wireless performance, its 802.11g signal was lost past 120 feet.

The AV6130HS-20 is a cool-looking system with plenty of impressive features, but it's definitely more of a plug-in-and-stay-put kind of notebook.—CC

### Dell Inspiron 600m

\$1,499 direct. Dell Inc., [www.dell.com](http://www.dell.com). ●●●●○

For students who don't want to add a monstrous laptop to their backpack load, the Dell Inspiron 600m is a great option. One of the lightest notebooks in this roundup at 5.4 pounds, this system includes the latest 1.5-GHz Pentium M 715 processor and a fast 5,400-rpm hard drive. Add to that a sturdy magnesium alloy case and impressive battery life (4 hours 8 minutes on our tests), and the 600m is ready to travel.

We like the 14.1-inch screen size, and though it is limited to 1,024-by-768 resolution, DVD playback is smooth. The 600m's performance scores were mostly middle of the road. And 802.11g wireless throughput was subpar, although it did maintain a signal out to 160 feet.

The 600m offers a bundle of software worth noting, including its proprietary Digital Media Experience (think Media Center "Light"), the full McAfee Security-Center suite, and WordPerfect Office 11.

Dell made some sacrifices to deliver this small form factor; for example, there's no FireWire port or memory card slot. And there are only two USB ports, while many competitors offer at least three. Although the hard drive is one of the fastest in the group, at 40GB it's smaller than most others.

For a good combination of portability and performance, the lightweight 600m is a solid choice. Yet it still can't compete with the hard-core components of the slightly heavier Velocity Micro system.—CC

### eMachines M6810

\$1,499 direct. eMachines Inc., [www.emachines.com](http://www.emachines.com). ●●●●○

Although it's a bit heavy, the cool and sleek eMachines M6810 is a feature-packed system that can fill the bill for back to school.

The system feels solid yet maintains a streamlined design, with a black exterior and blue LEDs. The 15.4-inch wide-screen display is the best in our roundup; its image quality is clear and crisp, especially when displaying DVD movies.

The M6810 comes with ample connectivity options, comprising four USB ports, a FireWire port, and a handy 6-in-1 memory card reader for transferring digital pic-

PERFORMANCE TESTS



We put our 18 back-to-school systems through a battery of performance tests, described below.

**Wireless tests** measure 802.11x throughput from an 802.11g access point. We test in an RF-free area, placing each system on a table rotating at 20 rpm.

**Business Winstone 2004** measures a PC's performance while running Windows-based business applications like Microsoft Office and Norton AntiVirus.

**Multimedia Content Creation Winstone 2004** measures a PC's performance when running content creation apps like Adobe Photoshop and Macromedia's Dreamweaver MX.

**3D Mark03** runs through scenes using various DirectX calls, including the latest version, DirectX9, to derive a score reflecting a graphics card's hardware and driver performance.

**Serious Sam: The Second Encounter** is a game we run using the OpenGL renderer; the scores reflect a graphics card's hard-

ware and OpenGL driver performance.

**Business Winstone 2004 BatteryMark** uses the tests of Business Winstone 2004 to drain a notebook's battery. BatteryMark inserts pauses between keystrokes and between tasks allowing the CPU to clock down as in a real-life scenario.

MOBILE VS. DESKTOP PROCESSORS

Seven systems had mobile processors, one had a Mobile Pentium 4 (in the Toshiba Satellite A45-S250), three had Pentium M processors, and three had Athlon XP-M processors. The Pentium M and 855 chipset are designed to slow a processor's clock speed dynamically and reduce voltage, thus reducing the power demand on the battery and power subsystems. The Mobile AMD Athlon XP-M is designed to extend system battery life using the AMD PowerNow! technology. The Velocity Micro NoteMagix B50 Campus Edition, loaded with the 1.7-GHz Pentium M 735, a 5,400-rpm hard drive, and an ATI Mobility Radeon 9700 with 128MB of DDR memory, achieved top marks on Business Winstone 2004 and most of our gaming tests.

The Averatec AV6130HS-20 and the HP Pavilion zx5000, both with the 3.06-GHz Pentium 4, tied for second place on the same test. This processor takes advantage of the LightWave multithreaded tests, part of the Multimedia Content Creation test.

Although the Pentium M processors in the Dell Inspiron 600m and WinBook W320 have the same clock speeds, the Dell system prevailed on Business Winstone, Content Creation Winstone, and BatteryMark tests. That's because Dell's model featuring the latest Pentium M 715 is based on 90 nanometer (nm) design, 2MB of L2 cache, and 21-watt thermal design, while the WinBook W320 is based on a 130-nm design, 1MB of L2 cache, and 24.5-watt thermal design.

The Fujitsu and Toshiba systems had the top two wireless scores in the \$1,000-to-\$1,500 roundup, and both carry the Atheros AR5001X wireless chipset.

—Analysis written by Cisco Cheng

High scores are best. Bold type denotes first place within each category. Distance ▶	802.11 ACCESS POINT Average throughput (Mbps)							
	"b"-only mode				"g"-only mode			
	1 foot	60 feet	120 feet	160 feet	1 foot	60 feet	120 feet	160 feet
<b>\$1,000 TO \$1,500</b>								
<b>Averatec AV6130HS-20</b>	4.9	5.5	5.2	—	20.6	10.7	7.9	—
<b>Dell Inspiron 600m</b>	6.0	6.0	5.3	3.9	19.8	15.6	4.9	2.0
<b>eMachines M6810</b>	<b>6.5</b>	<b>6.1</b>	<b>5.7</b>	4.9	21.4	17.4	6.4	2.8
<b>Fujitsu LifeBook S2020</b>	5.5	5.5	5.4	<b>5.3</b>	<b>21.9</b>	<b>22.3</b>	<b>15.6</b>	5.3
<b>HP Pavilion zx5000</b>	6.1	<b>6.1</b>	<b>5.7</b>	5.1	21.7	19.0	10.6	5.4
<b>Toshiba Satellite A45-S250</b>	5.4	5.4	5.3	<b>5.3</b>	21.8	22.2	11.9	<b>5.9</b>
<b>Velocity Micro NoteMagix B50 Campus Edition</b>	3.3	3.3	1.5	1.2	15.9	14.4	1.4	—
<b>WinBook W320</b>	5.5	5.2	4.9	1.6	20.4	18.2	5.8	—
<b>LESS THAN \$1,000</b>								
<b>Averatec AV3225HS</b>	6.1	6.1	5.7	<b>5.4</b>	20.0	<b>16.6</b>	<b>13.0</b>	<b>7.3</b>
<b>Dell Inspiron 1150</b>	6.1	6.1	1.6	0.6	<b>20.3</b>	13.0	2.1	0.8
<b>HP Compaq Presario R3000</b>	<b>6.4</b>	<b>6.4</b>	<b>5.8</b>	4.1	N/A	N/A	N/A	N/A

RED denotes Editors' Choice. N/A—Not applicable: The notebook could not complete this test. The Apple iBook G4 (12-inch) is not compatible with our Windows-based tests. A dash indicates that no wireless signal was received at this range.

High scores are best. Bold type denotes first place within each category. Resolution ▶ Anti-aliasing/Anisotropic filtering ▶	Processor	Business Winstone 2004	Multimedia Content Creation Winstone 2004	Business Winstone 2004 BatteryMark (hr:min)	3DMark03	3DMark03	Serious Sam SE (fps)	Serious Sam SE (fps)
					1,024 x 768 2X/2X	1,600 x 1,200 4X/4X	1,024 x 768 2X/2X	1,600 x 1,200 4X/4X
<b>\$1,000 TO \$1,500</b>								
<b>Averatec AV6130HS-20</b>	Pentium 4 (3.0 GHz)	16.3	22.7	1:59	1,913	N/A	52.9	N/A
<b>Dell Inspiron 600m</b>	Pentium M 715 (1.5 GHz)	16.4	19.2	<b>4:08</b>	329	N/A	41.0	N/A
<b>eMachines M6810</b>	Mobile Athlon 64 3000+ (1.8 GHz)	18.0	<b>23.7</b>	2:53	1,881	N/A	52.5	N/A
<b>Fujitsu LifeBook S2020</b>	Athlon XP-M (LV) 2100+ (1.6 GHz)	13.2	14.1	3:17	N/A	N/A	15.8	N/A
<b>HP Pavilion zx5000</b>	Pentium 4 (3.06 GHz)	16.2	22.7	2:46	1,506	N/A	<b>57.1</b>	N/A
<b>Toshiba Satellite A45-S250</b>	Mobile Pentium 4 (2.8 GHz)	19.1	21.8	3:50	N/A	N/A	19.8	N/A
<b>Velocity Micro NoteMagix B50 Campus Edition</b>	Pentium M 735 (1.7 GHz)	<b>21.5</b>	19.6	3:46	<b>2,394</b>	<b>1,017</b>	46.2	<b>20.6</b>
<b>WinBook W320</b>	Pentium M 715 (1.5 GHz)	13.6	17.1	3:25	N/A	N/A	17.4	N/A
<b>LESS THAN \$1,000</b>								
<b>Averatec AV3225HS</b>	Athlon XP-M 2000+ (1.7 GHz)	<b>13.6</b>	15.4	2:53	N/A	N/A	N/A	N/A
<b>Dell Inspiron 1150</b>	Celeron (2.6 GHz)	10.1	11.9	<b>3:03</b>	N/A	N/A	5.6	N/A
<b>HP Compaq Presario R3000</b>	Athlon XP-M 3000+ (1.6 GHz)	13.1	<b>16.6</b>	2:42	N/A	N/A	<b>28.4</b>	N/A

RED denotes Editors' Choice. N/A—Not applicable: The notebook could not complete this test. The Apple iBook G4 (12-inch) is not compatible with our Windows-based tests.



circuit  
**city**

circuitcity.com

**nu**  
**school**

everything you need for  
back-to-school, work & fun

Looking for the right computer and more at just the right price?

Shop at Circuit City for great prices on the latest technology  
to make the transition to your new school easier.

Shop online or in one of our 600+ stores to find all your essentials  
for work and fun—computers, printers, software, cordless and  
wireless phones, clock radios, digital cameras and more.

shop 24/7 & get free shipping on all your back-to-school essentials @ circuitcity.com

**\$30 gift card\***

great for last minute  
items after you  
get to campus!



with combined purchase of a notebook computer  
and any notebook computer accessory

Valid on any qualifying combined purchase made 6/1/04 through 9/5/04. Not valid on previous purchases. If either qualifying item is returned, return amount will be reduced by gift card value unless gift card is also returned. Notebook computer accessories include notebook power adapters, carrying cases, batteries, travel accessories & notebook mice. Not combinable with select Circuit City offers. Barcode valid for one use, in-store only. Reproductions or copies will not be honored. See store for details.



70Y15B757807896489

tures or class notes, for example.

Thanks in part to its Mobile Athlon 64 3000+ (the only 64-bit PC processor in this lineup), the system ranked number one on Multimedia Content Creation Winstone (23.7), and near the top on Business Winstone (18.0). And with the AMD PowerNow! technology, the M6810's battery life was a surprising 2 hours 53 minutes—not bad for a desktop replacement.

The system's 3D scores were also superb (1,881 on 3DMark03 and 52.5 on Serious Sam SE, both at 1024-by-768 resolution). On our wireless tests, the M6810 maintained a decent signal out to 160 feet.

When it comes to productivity and entertainment value, the M6810 would make a great companion for a student. But at 7.7 pounds, it's probably best to keep this system mostly deskbound.—CC

**Fujitsu LifeBook S2020**

\$1,379 list. Fujitsu PC Corp., www.fujitsu.com.

●●●○○

The lightest notebook in our roundup at 4.2 pounds, the Fujitsu LifeBook S2020 will appeal mostly to students who need to do basic computing (e-mail, word processing, and Internet browsing). This machine also offers high portability at a low price.

The 13.3-inch screen might be a bit small for researching term papers, but it delivers a bright, crisp image with a resolution of up to 1,600-by-1,200.

There's no Secure Digital slot, but the necessary ports are covered: two USB ports, one FireWire port, 100Mb Ethernet, and a modem. The DVD/CD-RW combo drive is standard fare in this class of notebooks and is sufficient for burning CDs and playing DVDs.

The S2020 includes a 1.6-GHz Mobile Athlon XP-M 2100+, which is decent. But its 256MB of RAM is barely enough for today's computing tasks, so we recommend upgrading to 512MB for about \$100. Also note that the ATI Mobility Radeon 9200 graphics solution shares its 16MB video memory with the unit's system memory, so don't expect exceptional graphics performance.

In general, the S2020's performance was low, though its BatteryMark score reached 3 hours 17 minutes, which is acceptable in light of the system's small battery. The S2020's wireless performance, however, impressed us; its 802.11g solution delivered 5.3 Mbps at 160 feet.

The S2020 is a good system for toting across campus, and it has enough battery power to get you through a morning of classes. But just remember, portability is its specialty, not features or performance.—CC



Fujitsu LifeBook S2020



eMachines M6810



Toshiba Satellite A45-S250

**HP Pavilion zx5000**

\$1,423 direct. Hewlett-Packard Co., www.hp.com.

●●●●○

The heavyweight of this roundup, the 8.5-pound HP Pavilion zx5000 is a desktop replacement in every sense of the term. No one would buy it to carry around campus. But as a multimedia system that stays put in a dorm room, this is a superb value that won't disappoint.

Both the bright 15.4-inch wide-screen display and outstanding Harman Kardon speakers lure gamers to the zx5000, as does its high graphics performance: It scored tops (57.1) on the 3D-intensive Serious Sam SE test, thanks to the ATI Mobility Radeon 9600 graphics solution.

Aside from your standard ports, there are three USB ports, a 5-in-1 flash card reader, as well as a proprietary USB digital drive for reading SD cards.

The Pavilion's software bundle stands out with Microsoft Office 2003, Quicken 2004, and multimedia applications, including Roxio's Easy CD Creator and InterVideo WinDVD.

The zx5000 was in the middle of the pack on Business Winstone (16.2), and it

scored above average on Multimedia Content Creation Winstone (22.7). Although it will mostly stay plugged in, its battery life (2 hours 46 minutes) is impressive for a desktop replacement. And its 802.11g wireless solution is also solid, receiving strong throughput (5.4 Mbps) at 160 feet.

The zx5000 is a feature-packed workhorse—good for both work and play, as long as you don't plan on sprinting across campus with it.—CC

**Toshiba Satellite A45-S250**

\$1,499 list. Toshiba America Information Systems Inc., www.toshiba.com.

●●●●○

The Toshiba Satellite A45-S250 is a fast, durable, desktop replacement system that can easily become an integral part of a student's dorm life. It's a good performer, but as with many desktop replacements, the trade-off is added weight.

The A45-S250's case is contoured at a sharp angle toward the front edge, which makes surfing on your lap a bit uncomfortable after half an hour or so. The 15-inch, 1,024-by-768 (XGA) display is a good size, but the Velocity Micro system offers better resolution.

Having four USB ports is useful, as is the dual-format DVD±RW drive—one of only two systems in this roundup to include this drive. Also included are a FireWire port, Secure Digital slot, and S-Video capabilities. But the word processing application—a must-have for students—is left out.

The A45-S250 made the grade on Business Winstone and Multimedia Content Creation Winstone, scoring 19.1 and 21.8, respectively. But it falls short on graphics, with the integrated Intel 855GME.

Its 802.11g wireless solution produced strong throughput at all distances. And the system turned in an exceptional score on BatteryMark (3 hours 50 minutes).

The A45-S250 has excellent performance



HP Pavilion zx5000

# Share the smiles all Summer long with Snapfish!



Summer vacation. Family get-togethers. Back to school. Every time you snap a photo this summer, think Snapfish. It's the easy and affordable way to print, share and store your photos online.



And satisfaction is 110% guaranteed!

Get 2 rolls of film developed



## FREE!

- High-quality prints on Kodak paper
- Free online photo sharing
- Free unlimited photo storage

Visit [www.snapfish.com/pcmag](http://www.snapfish.com/pcmag) today!

Offer expires 6/30/05; new Snapfish users only.

Get 25 digital camera prints



## FREE!

- Professionally developed, high-quality prints
- Prints for 19¢ each, every day
- Free online photo sharing and storage

Visit [www.snapfish.com/pcmag](http://www.snapfish.com/pcmag) today!

Offer expires 6/30/05; new Snapfish users only.

To redeem this special PC Magazine offer, you  
must go to [www.snapfish.com/pcmag](http://www.snapfish.com/pcmag)!

**snapfish**   
bringing people and pictures together

\*Offers good for new Snapfish members only. New account must be created at web address above to receive free offers. Free film developing is good on 2 rolls 35mm or 1 roll APS and is awarded upon registering with an address. Free digital camera prints are awarded upon upload of digital photo. S&H charges still apply. © 2004 SAC, LLC. The Snapfish logo is a registered trademark of SAC, LLC. All other trademarks are properties of their respective owners. All rights reserved.



WinBook W320



Velocity Micro NoteMagix B50

and durability, and students will appreciate the dual-format DVD drive and abundance of ports. But all in all, the eMachines M6810 and the HP Pavilion zx5000 are more well-rounded desktop replacement systems to get you through school.—CC

### Velocity Micro NoteMagix B50 Campus Edition

\$1,500 street. Velocity Micro Inc., www.velocitymicro.com. ●●●●●



Students who act fast can score a fantastic deal with a limited edition notebook from Velocity Micro. Through September 30, the NoteMagix B50 Campus Edition offers top-notch components, including the 1.7-GHz Pentium M 735, 128MB ATI Mobility Radeon 9700, and 60GB hard drive—all for \$1,500. That's easily the best combination of components in our roundup—all in a 6.2-pound system, which earns the B50 our Editors' Choice.

The B50 is a stylish and rugged, thin-and-

light system. All the standard ports are included: S-Video, VGA, FireWire, and USB 2.0 (3). There's also a Secure Digital slot for removable storage. The software bundle also warrants a mention, because it includes a decent multimedia suite (with DVD playback,

photo, and video apps) and the WordPerfect Productivity Pack (which includes WordPerfect, plus spreadsheet and address book apps).

The B50's graphics solution and 15-inch display (with 1,400-by-1,050 native resolution) are ideal for CAD designers and aspiring programmers who fit multiple windows and as much code as possible onto one screen. The B50 scored an impressive 2,394 on 3DMark03 and a 46.2 on Serious Sam SE at 1,024-by-768 resolution.

Perhaps the only disappointment is the B50's Intel Centrino 802.11g wireless solution, which performed below average out to 120 feet and lost its signal at 160 feet.

If you're a student looking for some serious productivity (and fun) but don't want to lug around a heavy system, then the B50 is right up your alley. It's built with hard-core components at a very competitive price. Catch it while you can.—CC

### WinBook W320

\$1,499 list. WinBook Computer Corp., www.winbook.com.



At first glance, the WinBook W320 may look perfect for students traipsing about campus; it has a 15.4-inch wide-screen display and weighs only 6.2 pounds. But its below-average performance, choppy DVD-movie playback, and lack of a word processor app make it tough to recommend.

The W320 includes a 1.5-GHz Pentium M 715 and is the only system here loaded with Win XP Pro. And thanks to the low-voltage processor, the system turned in a respectable battery score (3:25). But the W320's performance lagged behind the rest, with a meager 13.6 and 17.1 on Business Winstone and Multimedia Content Creation Winstone, respectively. The system's Centrino 802.11g wireless performed well out to 120 feet but lost signal at 160 feet.

The W320 comes with one FireWire, one VGA, one S-Video, one 100Mb Ethernet, and three USB ports. Like the Averatec AV6130HS-20, the W320 is also equipped with an S/PDIF port for digital audio. The 3-in-1 memory card reader comes in handy for storing and transferring files.

For a wide-screen notebook, the lackluster performance and choppy DVD playback are disappointing. This system as a whole just can't compete with the likes of the Velocity Micro notebook.—CC

## SUMMARY OF FEATURES

### Back-to-School Notebooks

	\$1,000 to \$1,500								Velocity Micro NoteMagix B50 Campus Edition	WinBook W320
■ YES □ NO	Apple iBook G4 (12-inch)	Averatec AV6130HS-20	Dell Inspiron 600m	eMachines M6810	Fujitsu LifeBook S2020	HP Pavilion zx5000	Toshiba Satellite A45-S250			
Price (tested configuration)	\$1,099 direct	\$1,449 list	\$1,499 direct	\$1,499 direct	\$1,379 list	\$1,423 direct	\$1,499 list	\$1,500 street	\$1,499 list	
Processor	PowerPC G4 (1.0 GHz)	Pentium 4 (3.0 GHz)	Pentium M 715 (1.5 GHz)	Mobile Athlon 64 3000+ (1.8 GHz)	Athlon XP-M (LV) 2100+ (1.6 GHz)	Pentium 4 (3.06 GHz)	Mobile Pentium 4 (2.8 GHz)	Pentium M 735 (1.7 GHz)	Pentium M 715 (1.5 GHz)	
Installed RAM	256MB	512MB	512MB	512MB	256MB	512MB	512MB	512MB	512MB	
Hard drive capacity	30GB	60GB	40GB	60GB	40GB	60GB	60GB	60GB	60GB	
Screen (diagonal, in inches)	12.1	15.4	14.1	15.4	13.3	15.4	15.1	15.1	15.4	
Built-in wireless type	802.11g	802.11g	802.11g	802.11g	802.11g	802.11g	802.11g	802.11g	802.11g	
System/travel weight (pounds)	4.9 / 5.7	7.7 / 9.5	5.4 / 6.3	7.7 / 8.8	4.2 / 4.9	8.5 / 9.6	7.6 / 9.1	6.2 / 7.0	6.2 / 7.0	
Graphics chipset	ATI Mobility Radeon 9200	ATI Mobility Radeon 9600	ATI Mobility Radeon 9000	ATI Mobility Radeon 9600	ATI Mobility Radeon 9200	ATI Mobility Radeon 9600	Intel 855GME	ATI Mobility Radeon 9700	Intel 855GME	
Optical drive	DVD/CD-RW	DVD±RW	DVD/CD-RW	DVD/CD-RW	DVD/CD-RW	DVD/CD-RW	DVD±RW	DVD/CD-RW	DVD/CD-RW	
Key pitch (mm)	19	19	19	19	19	19	19	19	19	
Pointing device	Touch pad	Touch pad	Touch pad	Touch pad	Touch pad	Touch pad	Touch pad	Touch pad	Touch pad	
Parallel/serial/VGA port	□ □ ■	■ □ ■	■ □ ■	□ □ ■	□ □ ■	■ □ ■	■ □ ■	■ □ ■	□ □ ■	
USB/FireWire ports	2 / 1	3 / 1	2 / 0	4 / 1	2 / 1	3 / 1	4 / 1	3 / 1	3 / 1	
Memory card types accepted	None	SD	None	CF, MD, MMC, MS, MSP, SD	None	MMC, MS, MSP, SD, SM	SD	SD	MS, SD, SM	
Standard lithium ion battery (whr)	61	63	52	65	43	88	91	63	48	
Warranty (parts and labor)	1 year	1 year	1 year	1 year	1 year	1 year	1 year	1 year	1 year	

RED denotes Editors' Choice. CF—CompactFlash, MD—MicroDrive, MMC—MultiMediaCard, MS—Memory Stick, MSP—Memory Stick Pro, SD—Secure Digital, SM—SmartMedia.



HP Compaq Presario R3000



Dell Inspiron 1150



Averatec AV3225HS

# NOTEBOOKS [LESS THAN \$1,000]

## Averatec AV3225HS

\$999 list. Averatec Inc., www.averatec.com.



Looking for a notebook that won't weigh you down, has terrific wireless performance, and handles everyday computing tasks with aplomb—all for under \$1,000? If so, look no farther than the Averatec AV3225HS, which earned our Editors' Choice in a recent sub-\$1,000 roundup and retains its title in this budget roundup.

The AV3225HS weighs just 4.5 pounds and measures just 1 inch thick, with a 12.1-

inch XGA display. The keyboard is full size, except for the <Period>, <Comma>, Alt, and Ctrl keys, which are 25 percent smaller.

For the most part, the AV3225HS didn't cut corners to keep the price and weight down. It includes a 40GB hard drive, three USB 2.0 ports, a VGA port, 100Mb Ethernet, a modem, and a PC Card slot. We found the DVD/CD-RW combo drive to be a little noisy during DVD playback.

Built around the low-voltage 1.7-GHz Athlon XP-M 2000+ processor, the AV3225HS garnered a respectable BatteryMark score of 2 hours 53 minutes. Of the budget notebooks, it came in first on Business Winstone and second on Multimedia Content Creation Winstone. Wireless performance was also strong, registering 7.3 Mbps at 160 feet.

The AV3225HS is great for taking to and from class, researching via the Internet, or writing term papers, but if you want a multimedia system and don't mind sacrificing portability, opt for the HP Compaq Presario R3000 with its wide screen. But if portability is your main concern, the AV3225HS won't weigh you down—or break the bank.—CC

## Dell Inspiron 1150

\$999 direct. Dell Inc., www.dell.com.



All notebooks with a price tag under \$1,000 have to make sacrifices. But the Dell Inspiron 1150 has made more than the others in this roundup, and that shows in its performance.

With an Intel Celeron processor, the 1150 is no speed demon. Of the sub-\$1,000 systems, the 1150 scored lowest on Business Winstone and Multimedia Content Creation Winstone.

The system also comes with only two

USB 2.0 ports, compared with the three ports that the other two budget notebooks in this roundup provide. This system's 30GB hard drive is also smaller than the others. But to the 1150's credit, it is well-stocked with WordPerfect Office 12 for term papers, as well as Paint Shop Pro and Paint Shop Photo Album for photo editing and storage. Also, including an 802.11g wireless solution is a plus; the HP Compaq Presario R3000 comes with only 802.11b. The 1150's signal dropped drastically, however, after 120 feet.

The 1150's 14.1-inch XGA display is a good size for writing papers and Web surfing. At 7 pounds it may not be the best notebook to lug to a lecture hall, but it is manageable. And its battery life of 3 hours 3 minutes bests all the other budget notebooks by at least 10 minutes.

The 1150 is a decent budget notebook, but we can't recommend it when others offer more features and better performance at a comparable price.—Lawrence Judd

## HP Compaq Presario R3000

\$993 direct. Hewlett-Packard Co., www.hp.com.



If you're looking for a bargain basement system to ease the back-to-school burden but don't want to sacrifice multimedia features, then the HP Compaq Presario R3000 could be the notebook for you.

The 8-pound R3000 has a sharp 15.4-inch WXGA display. The system had no problem displaying our test DVD movie clearly, and its JBL Pro speakers delivered superb sound quality. The nVidia GeForce4 420 Go graphics solution helped the R3000 win first place on our 3D performance tests. (Although our test system came with 802.11b, HP is offering free upgrades to 802.11g.)

On Multimedia Content Creation Winstone and our Serious Sam SE gaming demo, the R3000 had the best scores of the budget machines with 16.6 and 28.4, respectively. But we were surprised to find no memory card reader on a system with such multimedia-centric components. On BatteryMark, the R3000 lasted 2 hours 42 minutes, which was lowest among the budget systems.

The R3000 offers very good bang for the buck if you're on a budget but still want a spiffy multimedia system that will impress your dormmates. (Hey, you even get Microsoft Office SE 2003 for when it's time to get to work.) Shy away from the R3000, however, if you're looking for a more mobile system to carry around campus.—Charles Rodriguez

Download this table at  
www.pcmag.com

### Less than \$1,000

Averatec AV3225HS	Dell Inspiron 1150	HP Compaq Presario R3000
\$999 list	\$999 direct	\$993 direct
Athlon XP-M 2000+ (1.7 GHz)	Celeron (2.6 GHz)	Athlon XP-M 3000+ (1.6 GHz)
512MB	256MB	256MB
40GB	30GB	40GB
12.1	14.1	15.4
802.11g	802.11g	802.11b
4.5 / 5.3	7.0 / 8.1	8.0 / 9.6
VIA S3G	Intel 855GME	nVidia GeForce4 420 Go
DVD/CD-RW	DVD/CD-RW	DVD/CD-RW
19	19	19
Touch pad	Touch pad	Touch pad
□ □ ■	□ □ ■	■ □ ■
3 / 0	2 / 0	3 / 0
None	None	None
44	63	65
1 year	1 year	1 year

Dell Dimension 2400



Apple eMac



eMachines T3092



# DESKTOPS [LESS THAN \$800]

## Apple eMac

\$799 direct. Apple Computer Inc., [www.apple.com](http://www.apple.com).  
●●●○○

The entry-level Apple eMac is a good introduction to the Macintosh world, and it has the power to keep elementary- and middle-school students happy. With the extensive educational software selection found in your local Apple Store, the eMac makes a great learning tool. And like with the iBook, college students can save \$50.

The 1.25-GHz PowerPC G4 processor and 256MB of RAM make the system fine for basic tasks, such as word processing, e-mail, and spreadsheets, although for all-around better performance, we recommend a \$75 upgrade to 512MB of RAM. The 40GB hard drive is small by today's standards, but large

enough to hold thousands of one-to-five-page papers in addition to a host of educational titles. High school and college students might want to consider the eMac with a larger hard drive and SuperDrive optical drive.

Besides Mac OS X 10.3 Panther, QuickTime 6 and the excellent iLife suite are installed. The included software suite has the AppleWorks 6 word processor for writing papers, and the World Book Encyclopedia for researching them.

We found the eMac's Photoshop performance to be similar to the Windows desktop PCs reviewed here after we upgraded the eMac to 512MB of RAM. And with its ATI Radeon 9200 graphics card, it's capable of playing basic to intermediate 3D games and

2D educational games, although the Windows platform supports more games in general. If it's gotta be a Mac, young students will be well equipped with this box.  
—Joel Santo Domingo

## Dell Dimension 2400

\$799 direct. Dell Inc., [www.dell.com](http://www.dell.com).  
●●●○○

The Dell Dimension 2400 provides a decent feature set for students at a reasonable price. Although it's powered by the older 2.66-GHz Pentium 4, the system is loaded with 512MB of RAM, a spacious 80GB hard drive, a 19-inch CRT monitor, dual optical drives (one DVD-ROM and one CD-RW drive), and stereo Altec Lansing speakers with a subwoofer. But unlike the eMachines, HP, and iBuyPower offerings, the 2400 has no memory card reader.

Dell packs a generous software bundle with the 2400, though, including apps for word processing, researching papers, and

## SUMMARY OF FEATURES

### Back-to-School Desktops

Download this table at [www.pcmag.com](http://www.pcmag.com)

■ YES □ NO	Apple eMac	Dell Dimension 2400	eMachines T3092	HP Pavilion a610n	iBuyPower Back to School	WinBook PowerSpec 6244
Price (tested configuration)	\$799 direct	\$799 direct	\$710 direct	\$770 direct	\$799 direct	\$794 list
Installed OS	Mac OS X 10.3 Panther	Windows XP Home	Windows XP Home	Windows XP Home	Windows XP Home	Windows XP Home
Processor	PowerPC G4 (1.25 GHz)	Pentium 4 (2.66 GHz)	Athlon XP 3000+ (2.16 GHz)	Athlon XP 3000+ (2.16 GHz)	Athlon XP 3200+ (2.2 GHz)	Athlon XP 2800+ (2.25 GHz)
Installed/maximum RAM	256MB / 1GB	512MB / 2GB	512MB / 1GB	512MB / 1GB	512MB / 3GB	512MB / 2GB
Hard drive capacity	40GB	80GB	160GB	160GB	80GB	80GB
Hard drive speed	5,400 rpm	7,200 rpm	7,200 rpm	7,200 rpm	7,200 rpm	7,200 rpm
Screen (diagonal, in inches)	17	19	17	17	17	17
Maximum screen resolution	1,280 x 960	1,600 x 1,200	1,280 x 1,024	1,280 x 1,024	1,280 x 1,024	1,280 x 1,024
Graphics chipset	ATI Radeon 9200	Intel 845GL	nVidia GeForce4 MX	VIA S63 UniChrome	nVidia GeForce 3 Ti200	VIA KM400
Primary optical drive	DVD/CD-RW	DVD-ROM	CD-ROM	DVD-ROM	DVD/CD-RW	CD-RW
Secondary optical drive	N/A	CD-RW	DVD±RW	CD-RW	N/A	DVD-ROM
Parallel/serial/VGA port	N/A	■ ■ ■ ■	■ ■ ■ ■	■ ■ ■ ■	■ ■ ■ ■	■ ■ ■ ■
USB/FireWire ports	3 / 2	6 / 0	5 / 0	7 / 2	5 / 0	6 / 0
Speaker manufacturer	Apple	Altec Lansing	eMachines	Harmon Kardon	Mitsuko	Inland Pro Sound 2000
Memory card types accepted	N/A	N/A	CF, MMC, MS, MSP, SD, SM	CF, MMC, MS, MSP, SD, SM, xD	CF, MMC, MS, MSP, SD, SM	N/A
Warranty (parts and labor)	1 year	1 year	1 year	1 year	1 year parts, 3 years labor	1 year

RED denotes Editors' Choice. N/A—Not applicable: The product does not have this feature.  
CF—CompactFlash, MMC—MultiMediaCard, MS—Memory Stick, MSP—Memory Stick Pro, SD—Secure Digital, SM—SmartMedia, xD—xD-Picture Card.



organizing photos.

With a compact design, the 2400 has only one internal 3.5-inch bay for the hard drive. The lack of an AGP slot marries you to the integrated Intel graphics solution. You can, however, upgrade to 2GB of system memory, and there are three PCI slots, although one is used by the included 56K modem.

The 2400's performance was a mixed bag. It came in last on Business Winstone with a score of 17 and fared next to last on Multimedia Content Creation Winstone with a score of 22.9. Its performance was middle of the road on 3DMark03 with a score of 79, but was a top scorer on most of our Photoshop 7.01 tests.

Although the limited upgradability of this unit might be too restricting for those with computer-heavy majors, it does make a great buy for students with simple computing needs.—*William Pagan*

### eMachines T3092

\$710 direct. eMachines Inc., [www.emachines.com](http://www.emachines.com).



Students will have a hard time passing up the eMachines T3092, which earns our Editors' Choice. The built-in DVD±RW drive makes this system stand apart from other machines in the roundup, and the rest of its components make it a great value too.

For example, the 160GB hard drive—a capacity that only HP could match at this price point—makes this system ideal for a budget-conscious photo enthusiast or budding film student. While there is a memory card reader for photo transfer, film students will have to add a FireWire card to use a DV camera.

Upgrades are certainly possible, thanks to room for a couple of PCI cards and another hard drive. The nForce2-based motherboard also has an 8X AGP slot, which

## Dorm Entertainment Systems

Those who are planning to get a desktop PC for their dorm rooms anyway might want to consider one that's loaded with Microsoft Windows XP Media Center Edition or similar multimedia applications. Such PCs can double as your TV, DVD player, and stereo, saving valuable space and bringing your dorm some of the entertainment luxuries of home. Although the previously reviewed systems we outline below may seem pricey, most of them can be custom-configured to lower the cost. The same holds true for our new Editors' Choice in this category, the HP Media Center PC 1050y, which is reviewed in this issue's First Looks.—*KK*

**ABS Awesome 4300** Although not a true Media Center PC, the installed tuner card and DVR software make the 4300 act like one at a reasonable price.

With AMD Athlon 64 3000+, 512MB DDR 400 SDRAM, 120GB SATA hard drive, Samsung 19-inch CRT, 128MB nVidia GeForce FX 5700, DVD±RW and DVD-ROM drives, integrated six-channel audio, Creative I-Trigue 2.1 3300 speakers, Microsoft Windows XP Home Edition, \$1,295 direct. ABS Computer Technologies Inc., [www.abspc.com](http://www.abspc.com). ●●●●○

**Medion m3 5000 Director** Surprisingly easy to find in U.S. retail stores, this Media Center PC from a German company is reasonably priced and powerful.

With 3.0-GHz Pentium 4, 512MB DDR 333 SDRAM, 160GB hard drive, 17-inch LCD, 128MB nVidia GeForce FX 5200 graphics, DVD±RW and DVD-ROM drives, integrated audio, 2.1 speakers, Windows XP Media Center Edition, \$1,450 street. Medion USA Inc., [www.medion.com](http://www.medion.com). ●●●●○

**Sony VAIO PCV-V200G** This all-in-one form factor is great for tight spaces and quite stylish, although the screen and hard drive are a bit on the small side.

With 2.8-GHz Pentium 4, 512MB DDR 333 SDRAM, 120GB hard drive, 15-inch LCD, integrated SIS 651 graphics, DVD-RW drive, integrated audio, integrated Sony stereo speakers, Microsoft Windows XP Home Edition, \$1,699 direct. Sony Electronics Inc., [www.vaio.net](http://www.vaio.net). ●●●●○

can be used to upgrade to a high-power 3D graphics card. Although the system is a good 2D performer, as shown by its Business Winstone 2004 score (18.5), our gaming tests show you'll need an upgrade if you want to play 3D-intensive games.

The T3092 includes Microsoft Works 7.0, with Picture It! Premium. With Works, you can write reports and adorn them with digital pictures—all of which will look fine on the 17-inch CRT.

The T3092 is a good alternative for students who are into instant gratification. While you have to order direct from vendors like Dell, eMachines systems can be

found at local electronics megamarts, so you can try before you buy. For now, take our word: Most students can't go wrong with the T3092.—*JSD*

### HP Pavilion a610n

\$770 direct. Hewlett-Packard Development Co., [www.hp.com](http://www.hp.com). ●●●●○

The beginning of a school year brings with it plenty of concerns. The suitability of the stellar HP Pavilion a610n should not be one of them.

The a610n has an AMD Athlon XP 3000+ processor and large 160GB hard drive, along with separate DVD-ROM and CD-RW drives. HP takes advantage of this hardware with a nice software bundle. Microsoft Works 7.0 with Encarta will help in researching and writing papers. You can also copy CDs easily with Sonic Record Now! software, and touch up photos with HP's Image Zone Plus. Even Apple iTunes comes installed.

The system comes with a 17-inch CRT and two speakers (no subwoofer), which are sufficient to play video and listen to your music collection.

Attaching devices is easy with one FireWire and three USB ports on the front of the box. A sliding cover on the front hides a memory card reader and an



essentially obsolete floppy disk drive.

Finishing in the middle of the pack for this roundup on our benchmark tests (it does have integrated VIA S63 graphics), the a610n provides sufficient power to get school tasks done for years to come. For students who also want to enjoy music and digital photos along the way, the HP Pavilion a610n is a steal and worthy of an honorable mention.—*Alphonse Ragusa*

**iBuyPower Back to School**

\$799 direct. iBuyPower Computer, www.ibuypower.com. ●●●●○

Preteens and up will love the iBuyPower Back to School. Its case has a clear side panel, a neon strobe light inside, and a light-up letter Z cutout on the front-panel door. Inside, the powerful 2.2-GHz Athlon XP 3200+ CPU, snappy DDR system memory, and responsive 80GB hard drive with 8MB buffer helped the machine blow away the competition on our benchmark tests.

This system beat the WinBook PowerSpec 6244 (the second-best performer) by more than four points on Multimedia Content Creation Winstone and by more than one point on Business Winstone. And on 3DMark03 it scored far better than the second-best performer, the eMa-

chines T3092. This is not surprising, because of the system's 128MB nVidia GeForce3 Ti 200 AGP graphics adapter.

As potent as the machine is, however, it lacks productivity software, such as a word processor. The system comes with only CyberLink PowerDVD to play movies and Ahead's Nero to burn CDs. There's no photo software, but there is a memory card reader installed.

The included 17-inch CRT monitor is sharp. The three-piece speaker set, however, leaves something to be desired. There are three USB 2.0 connectors up front, in addition to headphone and microphone jacks.

The iBuyPower system is the right choice for students who know they'll occasionally need to alleviate school-related stress with games. Although it comes with few applications, it's easier to add software than it is to add the kind of performance that this machine already has.—*Omar Cintron*

**WinBook PowerSpec 6244**

\$794 list. WinBook Computer Corp., www.winbook.com. ●●●○○

The WinBook PowerSpec 6244 certainly has enough get-up-and-go for your basic academic computing tasks, but it trails similarly priced systems in features.

The 6244 doesn't include a word processor, and the CD-RW drive has to make due with Windows-writing capabilities. Roxio PhotoSuite 5 is included for work with photos, and the 17-inch CRT's display impressed us. You can store tons of MP3s on the respectable 80GB hard drive and queue them up with Musicmatch Jukebox. When playing tunes or movies with PowerDVD and the DVD-ROM drive, sound quality from the Inland Pro Sound 2000 speakers is mediocre at best.

Four USB 2.0 ports reside on the back of the chassis, and two USB ports and an open media drive bay are conveniently provided on the front of the tower. The sides of the tower also have cool built-in air vents.

The 2.25-GHz Athlon XP 2800+ is one of the lowest-rated processors in this roundup, but it still managed a second place score on Business Winstone at 19.2 and turned in a middle-of-the-road score of 23 on Multimedia Content Creation Winstone. Because of its paltry 32MB of shared graphics memory, the 6244 bombed out on 3DMark03 with a less-than-favorable score of 34.

Unless you enjoy excessive upgrading, you should pass on the 6244. Its mediocre performance and features just won't cut it on campus.—*Joseph A. Guilbeau IV*

PERFORMANCE TESTS



For primary- and secondary-school work, any of the PCs in this roundup will deliver fine performance, as shown by our Winstone performance scores. The difference between the top and bottom performers in this group is only about 20 percent on our Business Winstone 2004 test.

The Multimedia Content Creation Winstone 2004 scores show a larger gap. The top scorer, the iBuyPower, was about 26 percent above the lowest performer. The iBuyPower was the only box to go with an add-in graphics card, and it showed. The rest of the Windows PCs are clustered in the 22- to 24-point range, which means they will be competent at media creation

for even college design classes.

The nVidia GeForce 3 Ti200 card in the iBuyPower Back to School also helped it achieve top scores on 3DMark03. This means that the iBuyPower system alone will be able to handle a good number of 3D games as configured. Note that the Dell Dimension 2400 and Apple eMac are not upgradable with AGP graphics cards if your student "needs" a higher degree of gaming performance.

The Photoshop scores show that the eMac performs similarly to the Windows-based desktop PCs in this roundup, especially after we upgraded the eMac to 512MB of RAM, which was necessary for our testing.—*Analysis written by Joel Santo Domingo*

Processor	Business Winstone 2004 ▲	Multimedia Content Creation Winstone 2004 ▲	3DMark03 1,024 x 768 ▲*	PHOTOSHOP 7.01 TESTS (seconds) ▼				
				Gaussian blur (radius) 100 250	Unsharp mask	Lighting effects	Resize to 200%	
<b>Apple eMac</b>	PowerPC G4 (1.25 GHz)	N/A	N/A	7	19	5	4	21
<b>Dell Dimension 2400</b>	Pentium 4 (2.66 GHz)	17.0	79	4	15	2	3	20
<b>eMachines T3092</b>	Athlon XP 3000+ (2.16 GHz)	18.5	152	5	16	3	2	23
<b>HP Pavilion a610n</b>	Athlon XP 3200+ (2.2 GHz)	17.8	67	6	18	3	3	31
<b>iBuyPower Back to School</b>	Athlon XP 3200+ (2.2 GHz)	<b>20.6</b>	<b>1,041</b>	4	15	2	2	20
<b>WinBook PowerSpec 6244</b>	Athlon XP 2800+ (2.25 GHz)	19.2	34	6	18	3	3	22

RED denotes Editors' Choice. \* Anti-aliasing off, 2X anisotropic filtering. N/A—Not applicable: The desktop could not perform this test.

**BEST  
BUY**

Thousands of Possibilities

GET YOURS



# IPOWER

The #1 Selling eBusiness Solution Worldwide

**THE #1 FASTEST GROWING SHARED  
WEB HOSTING PROVIDER WORLDWIDE**



iPower is the largest Website Hosting provider in the United States. Our Internet based end-to-end solutions enable small and medium sized enterprises (SME's) to build, promote, manage and profit from their online presence.

iPower's market-leading, unique, and customer-centric suite of website hosting solutions has quickly become the first choice of SME's, webmasters, developers, designers and everyday Internet users worldwide looking to leverage the power of the Internet.

iPower has garnered several awards for outstanding performance and customer service, including 100Best's "Best Overall Host for 2002 & 2003" and Host Pulse's "World's Best Web Hosting Company." With iPower, you will feel confident that you are receiving rock-solid hosting, with quality customer service you deserve.

Sincerely,  
Thomas Gorny  
iPower CEO & President

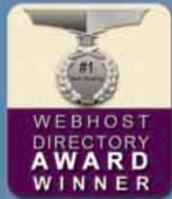

One of the Top 5  
Most Reliable Hosts



Top 3 - Most Popular



Host of the Year  
2002 & 2003

## DATA CENTER

iPower owns and operates four Internet data centers across the United States. Our world-class Tier 1 facilities are optimized to provide an industry-leading web, data, and applications hosting environment. We are strategically located on the highest quality of service backbone (AT&T's, Global Crossing and Cable & Wireless', Level3, Qwest and MFN OC48 / OC192 Global IP).



## CUSTOMER SERVICE

iPower has received many awards for their outstanding performance and superb customer service. The company has been named "Host of the Year" in both 2002 and 2003 by noted industry resource 100Best and was also awarded the title of "World's Best Web Hosting Company" by Host Pulse.



## CUSTOMER TESTIMONIALS

I was pleasantly surprised that tech support got back to me quickly and their answers were courteous, accurate, and succinct. Great!  
- Alan

I am very impressed with how fast you got back to me, I feel great knowing that I can e-mail you with a problem and know that I will receive a response within minutes.  
- Susan

I can say without reservation that I have never received better support. Everything you did was timely and error-free.  
- Bob

I just wanted to tell you how pleased I am with the software, training, and speed. It was much easier than I thought, and I could not be happier! Thanks!  
- David

I'm really impressed with the fast service you guys provide and the polite way you deal with what must seem very basic questions to you. Brilliant service! Thanks!  
- Sarah

I now have a few sites with you guys and believe me, I know the quality of your service, and it is a pleasure dealing with you. Your company is tops. Thanx again.  
- Dusty

SPECIAL PROMOTION OFFER:

[HTTP://WWW.IPOWER.COM/PCMAG](http://www.ipower.com/pcmag)

TEL: (888) 511-HOST  
24/7x365 LIVE CHAT AND HELP



## WHY IS IPOWERS THE RIGHT CHOICE FOR YOU?

### WEB HOSTING

#### iPower Pro Plan

- 800 Megs of Storage
- 400 Email Accounts
- 1 FREE DOMAIN
- SSL / CGI-BIN / MySQL
- Unlimited Email Forwarding
- FREE Marketing Tools
- FREE Content Package
- FREE \$50 Overture Credit

**\$7.95** per month

#### iPower Pro Plus

- 2 Gigs of Storage
- Unlimited Email Accounts
- 3 FREE DOMAINS
- SSL / CGI-BIN / MySQL
- Unlimited Email Forwarding
- FREE Marketing Tools
- FREE Content Package
- FREE \$50 Overture Credit

**\$12.95** per month

#### Virtual Server

- 10 Gigs of Storage
- Unlimited Email Accounts
- 10 FREE DOMAINS
- SSL / CGI-BIN / MySQL
- Perl and PHP Support
- Secure Telnet Access
- 100 Gig Transfer
- FreeBSD, Linux, Windows

**\$19.95** per month

### PRODUCTS & SERVICES

#### DOMAIN NAMES

**\$5.50**

- Lowest Pricing on the Net
- Get a FREE Parking Page
- Domain Utilities Manager
- FREE Email Forwarding

**Domain Name Registration**

#### WEB BUILDER

**\$4.95**

- FREE Domain / Email / Design
- Professional Web Templates
- Web Design Manager
- Logo Creator & Content Editor

**Web Design**

#### DEDICATED SERVERS

**\$49.00**

- 99.9% IP Network Reliability
- Four OC-48 Datacenters
- 24x7 Monitoring & Support
- Plesk 7 Control Panel

**Dedicated Servers**

### IPOWER BONUSES

Get \$50 Credit with

**overture®**

When You Register  
a Domain with iPower!

**FREE \$50 Overture Credit**



Search Engine  
Submissions,  
Banner Impression,  
Website Optimization  
Tools, and  
Comprehensive  
Guides.

**FREE Marketing Tools**

You can get up to

**10**

**Domain Names FREE!**

**FREE Domain Names**

SPECIAL PROMOTION OFFER:

**HTTP://WWW.IPOWER.COM/PCMAG**

**TEL: (888) 511-HOST**  
24/7x365 LIVE CHAT AND HELP

WIRELESS-G

# DUAL WAN ROUTER

# 2X

- BROADBAND CONNECTIONS
- RELIABILITY
- BANDWIDTH



H2WR54G

## HI-SPEED 54G

- Accepts Two ISP Connections (Cable/DSL)—Double the Bandwidth
- Traffic Management Feature Reduces Overall Network Traffic for Faster Connections
- Back up Feature Doubles the Reliability of Your Network by Switching ISPs When One Fails
- Ideal for Small Offices/Home Offices with High Demand for Speed and Reliability
- Great for Running Servers
- Compatible with Hawking Hi-Gain Antennas for Increasing Wireless Coverage
- Hi-Speed Wireless-G Networking—54Mbps
- Supports the Latest Wireless Security: WPA

### HOW IT WORKS



#### WHERE TO BUY:

amazon.com

Frys

COMPUSA

MICRO CENTER

COMPUTERS  
4sure

ICMall

buy.com

CDW

Insight

CONTACT: [WWW.HAWKINGTECH.COM](http://WWW.HAWKINGTECH.COM) • 1.888.662.8828

 **HAWKING**  
TECHNOLOGY

## IN THIS STORY

- 108 Brother MFC-3420c ●●●●○
- 108 Canon MultiPass MP360 ●●●●○
- 109 Canon MultiPass MP390 ●●●●○
- 109 Dell Personal All-In-One Printer A960 ●●●●○
- 109 Dell Photo All-In-One Printer 922 ●●●●○
- 110 HP Officejet 9130 All-in-One ●●●●○
- 110 HP PSC 2410 Photosmart All-in-One ●●●●○
- 111 Lexmark X2250 All-in-One ●●●●○
- 111 Lexmark X5250 All-in-One ●●●●○



■ Brother MFC-3420c



■ Canon MultiPass MP390

# ALL-IN-ONES: ONE FOR ALL

INK JET ALL-IN-ONES ARE BETTER CHOICES THAN EVER FOR PRINTING, FAXING, COPYING, AND SCANNING. WE PUT THEM TO THE TEST WITH INTENSIVE COST-PER-PAGE AND PHOTO-QUALITY ANALYSES.

BY M. DAVID STONE

Whether you think of them as multifunction printers (MFPs) or all-in-ones (AIOs), printer and scanner bundles are now the peripherals of choice for those who want it all—printer, copier, scanner, and fax machine. We look at nine of the latest.

AIOs have become so affordable—as low as \$100—that they’re muscling in on the low-end scanner market. According to research firm IDC, U.S. flatbed scanner shipments will drop from 5.8 million in 2002 to a projected 2.9 million in 2004, leveling off at about 2 million in 2007.

We were particularly interested in how well these units would handle photos, since several manufacturers are touting them as photo printers. We put them through our new photo test suite, which you can read more about on page 110.

We also include a cost-per-page analysis, with run-down tests on all the printers—and all their cartridges. Vendors’ testing methodologies differ, so we used one methodology across the board to see whether vendor claims are comparable. Find out if they are on page 108.

All of these printers have a simple setup routine and install Twain and WIA drivers. They all print, scan, and copy, and some fax.

We were generally pleased with most of these printers. They fared reasonably well, with photo quality scores ranging from good to excellent. If you’re willing to sacrifice a little speed or quality in the area you care least about, you really can have everything you need in one device.

## Brother MFC-3420c

\$180 street. Brother International Corp., www.brother.com. OVERALL RATING: ●●●●○ QUALITY RATINGS: Text: ●●●●○ Graphics: ●●●●○ Photos: ●●●●○



The Brother MFC-3420c doesn't outshine the competition in every category, but it is the most well-rounded of the bunch, turning in more than acceptable text, graphics, and photos at speeds you can live with and a price you can afford.

With a 20-sheet ADF (automatic document feeder), built-in fax modem, and front-panel controls that let it work as a standalone fax machine and copier, the MFC-3420c is a full-function unit. It also offers a separate cartridge for each of the four colors, which helps lower the cost per page. Although photos printed a little slowly on our performance tests, the MFC-3420c showed good speeds for text and graphics. On our business applications suite, the MFC-3420c was the fastest unit, claiming first or second place on 9 of the 13 individual tests, and first place in overall time, at 20 minutes 24 seconds. For the photo suite, however, it averaged 4 minutes for each 4-by-6-inch photo, and 9:32 for each 8-by-10.

Output quality rated very good for text and graphics and just short of that for photos. Cost per page was 2.6 cents per mono-



■ Canon MultiPass MP360

chrome page, the second best in this group, but 15.1 cents per color page, the third most expensive.

If you're looking for a photo printer that also handles text and graphics reasonably well, the MFC-3420c isn't your best choice. But if you print mostly from standard business applications and just need some decent photos from time to time, this one is perfect.

## Canon MultiPass MP360

\$130 street. Canon USA Inc., www.usa.canon.com. OVERALL: ●●●●○ Text: ●●●●○ Graphics: ●●●●○ Photos: ●●●●●

As far as photo printing from an AIO is concerned, Canon's got you covered. But printing from business apps is another story. The Canon MultiPass MP360 lacks an ADF and isn't the best or fastest at text and graphics.

But if you need something that prints, scans, and copies and delivers beautiful photos, this one is worth considering.

As with most Canon printers, setup requires installing a printhead and two cartridges and then running a manual alignment routine. The cartridges are relatively small, so you'll have to replace them more often than you would with other printers. The unit has no fax modem or fax support.

Performance on our business applications suite was unimpressive. The entire suite took 43 minutes 21 seconds to complete, making the MP360 the second slowest, behind the Lexmark X2250. It also ranked in the bottom third for every test in the suite that included color—which is all but one test.

Performance for photos was significantly better; the MP360 averaged 2:33 for each 4-by-6, and 5:44 for each 8-by-10. Output quality was also better for photos, earning an excellent rating, compared with the very good rating for text and graphics. Cost per page on our tests was 3.3 cents for a monochrome page and 12.4 cents for color—midrange rankings, though far closer in both cases to the least expensive printers to run. The MP360 isn't the ideal all-in-one, but if you're primari-

OUR CONTRIBUTORS: Associate editor Sarah E. Anderson and lead analyst M. David Stone were in charge of this story.

## COST-PER-PAGE ANALYSIS



When buying a printer, you should weigh the up-front cost and the cost per page (CPP), which can vary widely. But figuring out which printer is the least expensive to run is impossible when you have only vendor claims and no industry standard to go by.

For this roundup, we focused first on testing all the AIOs the same way to get comparable results. Second, we compared our findings with vendors' claims to see whether you could reasonably compare them against one another.

For each unit, we printed the same test file and tracked the number of pages printed for each cartridge. We considered a tricolor cartridge empty when any of the three ink colors ran out, but we tracked single-color cartridges separately.

After determining the average yield for each cartridge, we calculated the yield for 5 percent black coverage on a monochrome page and for 5 percent coverage of each color—or 20 percent total coverage—for a color page. We then divided the cartridge cost by the yield. We calculated vendors' claimed cost per page by dividing the cartridge cost by the vendors' claimed yields.

If you compare the claimed CPP with the tested CPP, you'll see that sometimes the vendor claims closely match our results and sometimes don't. The HP Officejet 9130, for example, scored best for cost per monochrome page on our tests and had the best claimed cost, with a difference of only 0.2 cents; for color, however, it ranked fourth in claimed CPP but had the best score on our tests, with a larger difference of 2.6 cents.

As expected, our results show that comparing vendors' claims won't help you determine which printer costs the least in the long run, but this table should.—MDS

Low numbers are best. Bold type denotes first place.	BLACK CARTRIDGES			COLOR CARTRIDGES		
	Claimed cost per page	Tested cost per page	PC Magazine ranking (5% coverage)	Claimed cost per page	Tested cost per page	PC Magazine ranking (20% coverage)
<b>TWO-CARTRIDGE PRINTERS</b>						
Canon MultiPass MP360	2.3¢	3.3¢	4	<b>3.2¢</b>	12.4¢	5
<b>Canon MultiPass MP390</b>	2.3¢	3.2¢	3	<b>3.2¢</b>	11.9¢	3
Dell Personal All-in-One Printer A960	—	5.2¢	8	—	17.8¢	8
Dell Photo All-in-One Printer 922*	3.9¢	4.1¢	7	5.3¢	12.2¢	4
HP PSC 2410 Photosmart All-in-One	4.4¢	3.4¢	5	8.7¢	12.5¢	6
Lexmark X2250 All-in-One*	7.1¢	8.8¢	9	11.6¢	21.8¢	9
Lexmark X5250 All-in-One*	5.3¢	3.9¢	6	6.7¢	11.5¢	2
<b>FOUR-CARTRIDGE PRINTERS</b>						
<b>Brother MFC-3420c*</b>	3.3¢	2.6¢	2	12.3¢	15.1¢	7
<b>HP Officejet 9130 All-in-One</b>	<b>1.9¢</b>	<b>1.7¢</b>	<b>1</b>	7.8¢	<b>10.4¢</b>	<b>1</b>

RED denotes Editors' Choice. \* Tested with a high-yield cartridge. A dash indicates that the information is not available.



ly interested in photos, it's one of the two best choices in this roundup, along with its near twin, the MP390.

### Canon MultiPass MP390

\$200 street. Canon USA Inc., [www.usa.canon.com](http://www.usa.canon.com).  
OVERALL: ●●●○ Text: ●●●○ Graphics: ●●●○  
Photos: ●●●●

With borderless printing, memory card slots, and some of the best photo output in this roundup, the Canon MultiPass MP390 leaves little doubt about its purpose. Like the Brother MFC-3420c (the other Editors' Choice), the MP390 is a well-rounded option; its strong suit, however, is photography, whereas the MFC-3420c's strength lies in business applications. With the exception of an ADF, the MP390 provides every feature you could hope for.

The MP390 offers a PictBridge USB camera port on the bottom right. Memory card slots hidden behind a small door let you print photos without a computer from eight types of cards. The front-panel buttons and LCD-based menu allow for direct printing as well as copying, faxing, and scanning.

Speed, however, is not one of the MP390's strengths. It took 42 minutes 6 seconds to complete the business applications suite, compared with the Brother entry, which reigned at 20:24 (the Lexmark X2250 All-in-One was last at 69:21). But it came in a strong third for both 4-by-6-inch photos and 8-by-10s. The output quality for everything ranges from very good to excellent, making up somewhat for the lackluster speed on business apps.

With only two cartridges, the MP390 manages to keep costs reasonably low, ranking third. Cost per page on our tests was 3.2 cents for monochrome and 11.9 cents for color.

The slow speed and low-capacity ink cartridges make this the wrong choice if you print lots of pages from business

## Business Applications: Brother MFC-3420c Photos: Canon MultiPass MP390



Picking the Editors' Choices for this story wasn't easy. We took into consideration each printer's initial price, cost per page, features, and quality and speed for both photos and business application documents, as well as the overall rating.

Many of the products performed well on some parts of our tests, but none performed well on every part. Since an all-in-one should be just that, we chose the two that really can function that way, with an emphasis on speed and output quality for business apps in the case of the Brother MFC-3420c and on photos in the case of the Canon MultiPass MP390.

Along with the MP390, the MFC-3420c offers very good business applications output. It also comes in first for speed and ranks second in cost per monochrome page, behind only the HP Officejet 9130, which costs \$820 more.

The MP390, on the other hand, produced excellent photo output (along with the MP360, which we also highly recommend for those who don't need fax support). The MP390 ranks third behind the 9130 and the Lexmark X5250 for cost per color page, but the X5250 lags far behind the MP390's photo speed. Most important, though, both the Brother and Canon units delivered passable results even in the categories that aren't their strengths. With these two printers, you truly do get it all—in one.

apps, but if you print primarily photos and still need to fax—or just print from Microsoft Word and Excel once in a while—you'll be more than pleased with this choice.

### Dell Personal All-In-One Printer A960

\$180 street. Dell Inc., [www.dell.com](http://www.dell.com). OVERALL: ●●●○  
Text: ●●●○ Graphics: ●●●○ Photos: ●●●●

With its 50-page ADF and standalone fax capability—along with copy, scan, and print features—the Dell Personal All-In-One Printer A960 easily qualifies as a full-function AIO. But it doesn't win any contests for speed or quality.

On our tests, the A960 was relatively slow for both test suites. It completed the business applications suite in 36 minutes 1 second, compared with 20:24 for the Brother MFC-3420c, which offers similar features for the same price. In addition to the faster overall speed, the Brother unit beat the A960 on 10 of the 13 individual tests. For photos, the A960 was somewhat faster than the MFC-3420c, averaging 3:45 for each 4-by-6 and about 8:51 for each 8-by-10.

The A960 earned a rating of good for both text and graphics quality and very good for photos.

Here again, the Brother MFC-3420c did better for business applications and worse for photos,

with a very good rating for text and graphics but a little short of very good for photos. More important, the A960 is the second most expensive printer in this group to run, at 5.2 cents per monochrome page on our tests and 17.8 cents per color page.

This combination of performance, output quality, and running costs suggests you should look elsewhere if you print mostly from business apps or print lots of pages. But if features come first, the A960 has the edge with its hefty ADF and fax capability.

### Dell Photo All-In-One Printer 922

\$130 street. Dell Inc., [www.dell.com](http://www.dell.com). OVERALL: ●●●○  
Text: ●●●○ Graphics: ●●●○ Photos: ●●●●

The Dell Photo All-In-One Printer 922 is the only AIO here built around a photo printer engine instead of a standard one. That explains why it is one of the fastest for photos but is relatively slow for business apps. As you might expect for the price, its AIO features are minimal, with no ADF or fax modem.

The 922 does offer the choice of four or six colors in its two cartridges, bringing its focus slightly more to photography. You can either load black and tricolor cartridges for four-color printing, or replace the black cartridge with one that has black, light cyan, and light magenta for six colors.

Photos are fast, averaging 2 minutes 13 seconds for each 4-by-6 and 5:07 for each 8-by-10. That's a virtual tie with the \$300 HP 2410, which averaged just 2 seconds faster for a 4-by-6. The 922 also



■ Dell Personal All-In-One Printer A960 (left),  
■ Dell Photo All-In-One Printer 922



■ **HP Officejet 9130 All-in-One (left),**  
 ■ **HP PSC 2410 Photosmart All-in-One**

### HP Officejet 9130 All-in-One

\$1,000 street. Hewlett-Packard Development Co., [www.hp.com](http://www.hp.com). OVERALL: ●●●●○ Text: ●●●●○ Graphics: ●●●●○ Photos: ●●●●○

Clearly in a class by itself here, the \$1,000 HP Officejet 9130 All-in-One is the most expensive choice by far to buy, but it's the least expensive to run. It's also the only one with an

Ethernet connection, and one of two models we tested with a 50-page ADF. Most interesting, it's the only one that lets you scan and e-mail directly from the unit, with a little built-in keyboard for entering e-mail addresses.

You can either set up the 9130 as a standalone fax machine, copier, and digital sender (for e-mail), or connect it to a network or PC via a USB or parallel port.

Performance was a mixed bag. The 9130 did well on our business applications suite, placing first or close to it on 9 of the 13 documents with a total time of 21 minutes 21 seconds, compared with 20:24 for the leader. For photos, however, it was next to last, averaging 4:45 for each 4-by-6 and just shy of 16 minutes for each 8-by-10.

Photo quality ratings are acceptable, but not good enough to justify the long wait. The 9130 also earned a rating of good for

graphics quality and very good for text. Costs per page were the best in the group, at 1.7 cents per monochrome page and 10.4 cents per color page.

The 9130 is not for everyone, but its long list of features, combined with strengths in text quality, running costs, and speed for business applications, clearly makes it one of the best AIOs for a small office or workgroup.

### HP PSC 2410 Photosmart All-in-One

\$300 street. Hewlett-Packard Development Co., [www.hp.com](http://www.hp.com). OVERALL: ●●●●○ Text: ●●●●○ Graphics: ●●●●○ Photos: ●●●●○

As you might guess from the name, the HP PSC 2410 Photosmart All-in-One offers a variety of photo features and fast times for photo printing. But it's also a good fit for most other purposes, including copying, scanning, faxing with the built-in fax modem, and printing from business applications. The only important missing capability is an ADF, but the 2410 does offer USB 2.0 and parallel ports.

Built around a standard ink jet engine rather than a photo engine, the 2410 still lets you swap out the black ink cartridge for a photo cartridge to switch between four- and six-color printing. Cost per page ranked in the middle but was toward the low end for actual costs, at 3.4 cents per mono-

ties the HP printer for photo quality at just short of very good.

The photo speed doesn't carry over for business apps, but the 922 performed well when printing just black text. Its time on our business applications suite was 35:08, compared with 26:57 for the HP 2410. But with a rating of good for both text and graphics, the 922 slightly beat the HP 2410 for quality. Running costs are uneven, at a high 4.1 cents per monochrome page on our tests, but a relatively low 12.2 cents for a color page.

The 922 is a reasonable choice if you're more interested in photos than documents and spreadsheets, and if you plan to print them in color rather than black and white.

## PERFORMANCE TESTS

# What the New Numbers Mean



Photo printing is all the rage—even with AIOs. So now is a great time to upgrade our benchmark tests. We started by switching to Microsoft Office 2003 for business applications and

PageSense 4.0 for our testing application. (You can find out more about this software at [www.qualitylogic.com](http://www.qualitylogic.com)). We also updated our test images, changed the name of one of our test suites, and added a new suite.

We've been using these tests in First Looks for a few months, and you'll see them there and in feature stories to come.

What was the Performance suite is now the Business Applications suite, since we test with Adobe Acrobat and Microsoft Excel, PowerPoint, and Word. We've also incorporated more graphics and photos

### BUSINESS APPLICATIONS (default settings)

All times are in minutes:seconds.  
 Low scores are best.  
 Bold type denotes first place.

	Adobe Acrobat 6.0		Microsoft Excel 2003			Microsoft PowerPoint 2003	Microsoft Word 2003				
	4 pages, text and photos Portrait mode	Landscape mode	1-page table		3 pages, charts and graphs	4 full-page slides	2 pages, text	2 pages, text and clip art	2 pages, text and photos	12 pages, monochrome text	12 pages, color text
<b>Brother MFC-3420c</b>	<b>1:46</b>	<b>2:01</b>	0:23	0:23	1:32	2:20	0:52	0:51	0:53	4:08	4:13
Canon MultiPass MP360	5:23	5:02	0:27	0:28	3:37	5:20	2:25	2:27	2:25	2:11	10:38
Canon MultiPass MP390	5:18	4:57	0:22	0:22	3:33	5:14	2:21	2:22	2:20	2:07	10:22
Dell Personal All-in-One Printer A960	6:06	5:49	0:13	0:13	3:46	5:47	1:24	1:24	2:27	1:56	4:54
Dell Photo All-in-One Printer 922	4:48	4:30	<b>0:11</b>	0:10	2:58	4:26	1:59	2:01	1:59	<b>1:42</b>	8:07
HP Officejet 9130 All-in-One	4:20	4:31	0:14	0:15	<b>1:14</b>	<b>1:57</b>	<b>0:48</b>	<b>0:50</b>	<b>0:50</b>	2:31	<b>2:26</b>
HP PSC 2410 Photosmart All-in-One	3:16	3:02	0:27	0:22	2:05	3:17	1:32	1:32	1:30	2:45	5:13
Lexmark X2250 All-in-One	11:45	10:58	0:20	0:19	7:11	11:23	3:05	3:06	4:56	2:52	9:54
Lexmark X5250 All-in-One	4:50	4:31	<b>0:11</b>	<b>0:09</b>	2:58	4:26	1:59	2:01	1:59	1:43	8:03

RED denotes Editors' Choice. N/A—Not applicable: The product could not complete this test. \* Total derived from all the tests in this suite, including some not shown here.

- Lexmark X5250 All-in-One (left),
- Lexmark X2250 All-in-One



### Lexmark X2250 All-in-One

\$100 street. Lexmark International, www.lexmark.com.  
 OVERALL: ●●●○○○ Text: ●●●○○○  
 Graphics: ●●●○○○ Photos: ●●●●○○

In almost every way, the Lexmark X2250 All-in-One offers minimal capabilities, with no fax modem and no ADF. It prints good graphics and very good photos, but its speed and text quality are barely passable—if that. At only \$100, however, it is the lowest priced unit here.

The X2250 connects via USB 2.0, but you'll find little need for the extra throughput, as slow speed is this printer's trademark. On our business applications suite, it came in last overall and on 9 of the 13 tests. It offered slow but tolerable speeds for monochrome text, printing a 12-page monochrome Word file in 2 minutes 52 seconds.

Slowing down even more for files with graphics, photos, and color, the X2250 turned in a total time of 69:21 for the suite, 26 minutes longer than the next slowest printer. For 4- by 6-inch photos, it averaged 11:26 each. We didn't test it with 8-by-10s, because it didn't meet our required 10-minute maximum for 4-by-6s.

Output quality was inconsistent, with

ratings of very good for photos, good for graphics, and fair for text. The low text rating, however, stems from problems printing two highly stylized fonts; with more common fonts, the text is readable at 5 points or smaller. Although it's the least expensive to buy, our cost-per-page tests rank the X2250 as the most expensive printer in this group to run, at 8.8 cents per monochrome page and 21.8 cents per color page.

The combination of slow speed, middling quality, and high running costs leaves little reason to consider the X2250. You can get a much better printer at only a slightly higher price.

### Lexmark X5250 All-in-One

\$120 street. Lexmark International, www.lexmark.com.  
 OVERALL: ●●●○○○ Text: ●●●○○○ Graphics: ●●●○○○  
 Photos: ●●●●○○

The Lexmark X5250 offers basic AIO functions, with no fax modem or ADF. But what it does, it does reasonably well.

The X5250 is neither speedy nor intolerably slow. On our business applications suite, it took 35 minutes 6 seconds, making it the fourth fastest. It even scored first place on the three monochrome-only tests. For photos, it was one of the slower units, averaging 4:24 for the 4-by-6s and 10:09 for the 8-by-10s. That translates to about twice as long as the fastest models in the group, but well under half the time of the slowest.

And the photos are worth waiting for, with a quality rating of very good. Text and graphics quality are a bit lower, with a rating of good for text and a bit better than fair for graphics. Running costs on our tests came out to a relatively high 3.9 cents per monochrome page, but a low 11.5 cents per color page—the second least expensive here.

If initial price is paramount and you're primarily interested in photos, you might want to spend just a bit more for the Canon MP360, which offers better photo quality at faster speeds. If you're more interested in general-purpose printing, the X5250 is a reasonable choice. But be sure to consider the Dell 922 also, which closely matches the X5250 for text and graphics but is somewhat faster for photos, with slightly lower quality. ≡

## MORE ON THE WEB

For more information on the latest printers, as well as an extended benchmark table, What the Numbers Mean, and a features table, visit [www.pcmag.com/printers](http://www.pcmag.com/printers).

chrome page and 12.5 cents for color.

The 2410 ranked first on our photo suite, averaging 2 minutes 11 seconds for 4-by-6s, and 4:58 for 8-by-10s. With standard business apps, it beat most of the competition on all but three individual tests, and it came in third for a total time of 26:57, only about 6 minutes behind the Brother MFC-3420c, which took first place at 20:24.

Unfortunately, the 2410's output quality was not as impressive as its speed, with a rating of good for text, a little better than fair for graphics, and just short of very good for photos. These translate to decent, but not terrific, output. You can get better quality at a slightly slower speed for less money.

into these business documents to reflect how people print today. The Quality suite has been replaced by the Photo suite, focusing on quality and speed specifically for photos.

We have also changed the way we report quality results. Now we provide separate scores for text, graphics, and

photos, so you can see the score for the types of output that interest you. Each element is rated on an ascending scale from 1 to 5. Photo quality scores are based primarily on the photo suite output using high-quality paper. For an extended explanation of what the numbers mean, visit [www.pcmag.com/printers](http://www.pcmag.com/printers).—MDS

### PHOTOS (high-quality settings)

Adobe Photoshop 7.0

TOTAL OUTPUT TIME*	4" x 6" color photo			TOTAL OUTPUT TIME: 4" x 6" prints	8" x 10" monochrome photo	8" x 10" color photo	8" x 10" color photo montage	TOTAL OUTPUT TIME 8" x 10" prints
	A	B	C					
<b>20:24</b>	3:16	4:31	4:13	12:00	12:08	7:11	9:19	28:38
43:21	2:33	2:35	2:34	7:42	5:45	5:44	5:44	17:13
42:06	2:25	2:31	2:30	7:26	5:39	5:40	5:40	16:59
36:01	3:45	3:45	3:45	11:15	8:49	8:53	8:52	26:34
35:08	<b>2:11</b>	2:14	2:14	6:39	5:12	5:00	5:10	15:22
21:21	4:38	4:33	5:12	14:23	17:20	15:21	15:10	47:51
26:57	2:15	<b>2:09</b>	<b>2:09</b>	<b>6:33</b>	<b>4:56</b>	<b>4:59</b>	<b>4:59</b>	<b>14:54</b>
69:21	11:27	11:28	11:22	34:17	N/A	N/A	N/A	N/A
35:06	4:22	4:26	4:24	13:12	10:17	10:02	10:09	30:28

# eMachines®

eMachines is for everyone

## PROMISES MADE. PROMISES KEPT.

eMachines recommends  
Microsoft® Windows® XP

**"The Pharaohs** promised to build great wonders of the world. **They did!"**

eMachines' customers continually marvel at how we build great, feature-rich, notebook computers at such an affordable price. **We do it to fulfill our promise to deliver power, reliability and high value in every computer we build.**

No wonder *PC Magazine* says, eMachines can "boast the best performance scores of any notebook we tested." (March 2004)

For information on buying a computer that will stand the test of time, visit our web site or your local retailer today.

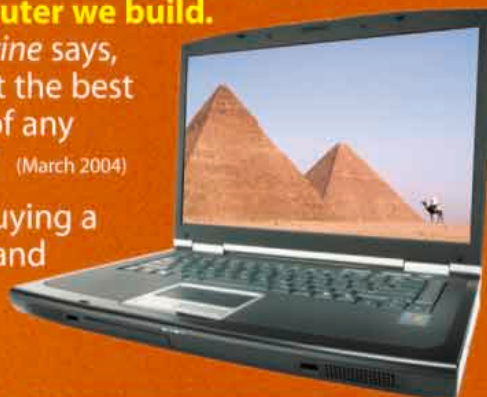

### eMachines M6810

Mobile AMD Athlon™ 64 Processor 3200+ with Enhanced Virus Protection for the upcoming Microsoft® Windows® XP SP2  
Microsoft® Windows® XP Home Edition

15.4" Digital Widescreen  
TFT LCD WXGA

512 MB DDR

60 GB HDD<sup>2</sup>

CD-RW/DVD Combo Drive

ATI® RADEON™ 9600 Discrete Graphics with 64 MB DDR Video Memory

Integrated 802.11g  
Wireless LAN (up to 54Mbps)

10/100Mbps built-in Ethernet

Software includes:  
Microsoft Works 7.0 & Money 2004  
Norton AntiVirus™ 2004<sup>3</sup>  
AOL - 3-month membership<sup>4</sup>  
(90-day subscription included)  
One year technical support<sup>5</sup>

**\$1399.99\***

\*After \$100.00  
Mail-in Rebate<sup>1</sup>

### Upgrade to the eMachines M6811 for only \$200.00!

You get:

Mobile AMD Athlon™ 64 Processor 3400+ with Enhanced Virus Protection for the upcoming Microsoft® Windows® XP SP2

Microsoft® Windows® XP Home Edition

512 MB DDR

80 GB HDD<sup>2</sup>

Multi-format DVD-RW

**\$1599.99\***

\*After \$100.00  
Mail-in Rebate<sup>1</sup>

Visit [www.eMachines.com](http://www.eMachines.com) to see our full line of products



Strike the perfect  
balance between  
exceptional  
performance and  
true mobility



All offers valid in US only and are subject to change without notice or obligation. May not be available through all sales channels. 1. For more information about rebate offer, log on to [www.emachines.com/news/rebate.html](http://www.emachines.com/news/rebate.html) or call 1-800-786-0797. 2. Accessible capacity varies: MB = 1 million bytes; GB = 1 billion bytes. 3. Ninety days of LiveUpdate feature included. Internet connection required. 4. Additional phone charges may apply. Call 1-800-846-2000 for details and access numbers. Check the number you select with your local phone company. New US members 18+ only. Major credit card or checking account required. 5. Telephone Technical Support is at no additional charge for one year from date of purchase. Long distance charges may apply, depending on your calling area. Copyright © eMachines, Inc. All rights reserved. eMachines Terms and Conditions of Sale apply. eMachines is either a trademark or registered trademark of eMachines, Inc. in the United States and/or other countries. AMD, Athlon and HyperTransport are trademarks of Advanced Micro Devices, Inc. Norton AntiVirus is a trademark of Symantec Corporation. ATI, RADEON 9600 are trademarks of ATI Technologies, Inc. Microsoft and Windows are either registered trademarks or trademarks of Microsoft Corporation in the United States and/or other countries. Other trademarks are property of their respective owners.

Ad Code: 115360

# Unleash Your Printer

Adding a wireless print server to your network won't make you rich or powerful, but you will have one less cable to trip over.

BY CRAIG ELLISON AND  
OLIVER KAVEN

CONTRARY TO POPULAR BELIEF, THE benefits of a home wireless network don't begin and end with a free-flowing Internet connection. Wireless print servers are liberating printers everywhere, allowing users to print with reckless abandon from anywhere in the house.

Of course, printer sharing at home and in small offices is nothing new. Wired print server devices have been doing the job for years, and many network-enabled printers have sharing capabilities built-in. Most people, however, have shared their personal printers by using a single Windows PC on a given network as a print server. There's a downside to this: The dedicated PC must always be on for others to print.

Wireless print servers simplify the concept and save on electricity, too. You simply plug one into any printer via a USB or parallel port; the server then communicates with your wireless router and in turn with any wireless or wired PCs on your network.

You can also manage such print servers remotely via a Web browser interface or through telnet, so you can manage a printer that is in another room or even in an entirely different location.

Before you buy one, though, there are several things to consider. Make sure that



## IN THIS STORY

**114** Axis OfficeBasic USB ●●●●○

**114** Belkin FIUP001 ●●●●○

**115** D-Link DP-311U ●●●●○

**115** Hawking HWPS12UG ●●●●○

**115** Linksys Wireless-G WPS54GU2 ●●●●○

**116** SMC EZ Connect SMC2621W-U ●●●●○

**115** Editors' Choice

**115** Performance Tests

**116** Two for the Office

the print server you are interested in supports a network protocol that your PC's OS can understand (such as NetBEUI, SMB, or AppleTalk). Also keep in mind that if you own or plan to purchase a multi-function printer, a print server won't support features like faxing or scanning in such devices. Finally, most print servers won't support useful feedback features that many printers provide when they are directly attached to a PC: alert messages warning when ink levels are low, paper is jammed, or your printer is out of paper.

Security can be an issue as well. All of the print servers we review here support only WEP. This may be sufficient for home use, but businesses might find it problematic and should consider WPA security instead. The manufacturers assure us that WPA support will appear in more models soon.

Following are reviews of six wireless print servers (a mix of 802.11b and 802.11g) for the home and small office. We also look at two more expensive and more complex products for business use.

### Axis OfficeBasic USB

\$139 list. Axis Communications, [www.axis.com](http://www.axis.com).  
●●●●○

With broad protocol support, excellent range, and a low price, the Axis Office-Basic (OB) USB print server impressed us

## SCORECARD



Our **setup and installation** rating favors products that are simple to deploy. Products providing multiple and intuitive **configuration and management** interfaces fare

best. Those products with useful and innovative additional **features** receive high marks. **Security** could have been

better on all the products: We think WPA support should be mandatory, but none go beyond WEP. Products with the best print times and longest range receive the highest **performance** ratings. The **overall** rating is not a mathematical average but an aggregate score based on testing and debate among PC Magazine Labs staff.

	Setup and installation	Configuration and management	Features	Security	Performance	OVERALL
Axis OfficeBasic USB	●●○	●●●	●●●○	●●○	●●●○	●●●○
Belkin F1UP001	●●○	●●●	●●●	●●○	●●●○	●●●
D-Link DP-311U	●●○	●●●	●●●	●●○	●●●	●●○
Hawking HWPS12UG	●●●○	●●●○	●●●○	●●○	●●●○	●●●○
Linksys Wireless-G WPS54GU2	●●●○	●●●	●●●	●●○	●●●○	●●●
SMC EZ Connect SMC2621W-U	●●	●●●	●●○	●●○	●●	●●

●●●●—EXCELLENT  
●●●●—VERY GOOD  
●●●—GOOD  
●●—FAIR  
●—POOR

RED denotes Editors' Choice.

for the most part. Despite its lack of an external antenna the OB delivered average print times throughout our entire 160-foot wireless test range.

This 802.11b server has a single USB 1.1 port for connecting to a printer. Unlike other products here, it lacks an Ethernet port, so initial configuration has to be done

wirelessly. By default, the OB server associates with the access point (AP) with the best signal and obtains an IP address.

One thing not mentioned in the instructions for initial hardware installation is that you must disable WEP on your access point to configure the server. Only in subsequent configuration is this noted.

The interface also includes a site-survey tool showing the SSID of all of the APs that the server hears, along with operating channel, signal strength, and encryption mode.

Two final features impressed us: the product's print queue, which allows you to view pending jobs, and the log, which displays and records each job by size, port number, and the protocol used.—CE

### Belkin F1UP001

\$129.99 list. Belkin Corp., [www.belkin.com](http://www.belkin.com). ●●●○

The highlights of this handsome 802.11g print server are consistent wireless performance all the way out to 160 feet, two USB ports instead of one, and a nice price.

The USB 1.1 ports let you attach and share two printers. An integrated wired Ethernet port is included, so you can wire the printers directly to the network; when using this port, however, the wireless capabilities of the server are automatically disabled.

We found the setup process a bit clunky, with too many steps as compared

## Two for the Office

Although the devices in our main roundup are for homes and very small offices, HP and TROY each offer business-focused 802.11b wireless print servers that cost about \$100 more. Their features include extended protocol support, centralized management, and in the case of the HP product, bidirectional alerts (paper out, ink out, and the like) for some HP printers.

### HP Jetdirect 380x

What the HP Jetdirect 380x lacks in wireless performance and cutting-edge technology, it makes up for in security, protocol support, and centralized management tools. It does require a bit more expertise to configure, but with its Web JetAdmin utility, you can manage multiple HP print servers

The HP device also provides the most security of all the products in this story, with 168-bit encryption, access control lists, and RADIUS for user authentication.

Its extensive, built-in protocol support includes IPP, LPD, and FTP printing as well as Network and AppleTalk support.—OK

\$239 list. Hewlett-Packard Development Co., [www.hp.com](http://www.hp.com). ●●●○

### TROY PocketPro USB

Despite impressive management tools, the TROY PocketPro USB is disappointing, particularly in its performance: It scored lowest among all the print servers. But it does offer support for the HP JetAdmin utility, Netware, and more.

The PocketPro also has an impressive level of print control. It is the only device here that lets you configure each print service—such as binary, Postscript, text, and AppleTalk—for network protocols and specific print strings. The device is limited to WEP, though support for WPA is scheduled to arrive in 2005.—CE

\$240 direct. TROY Group Inc., [www.troygroup.com](http://www.troygroup.com). ●●●○

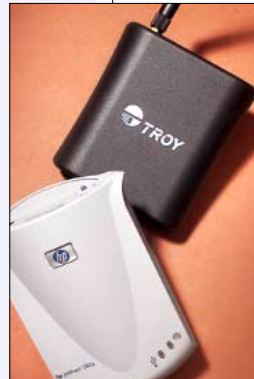

with some of the other products. For instance, the installation wizard instructs you to connect your printer directly to each computer that will be sharing it, and then install the printer manufacturer's drivers before running the rest of the wizard. At this point the wizard directs you to set up the Belkin port redirector. Finally, you run a separate program, found on the installation CD, that searches for your print server and launches the Web-based management interface.

Overall, Belkin's print server is a solid choice, though the Hawking HWPS12UG offers even more at about the same price.—CE

### D-Link DP-311U

\$149 direct. D-Link Systems Inc., www.d-link.com.

●●●○○

This basic device offers few features and mediocre performance, at a higher price than most of the other print servers in our home/small-office roundup. Only the Linksys print server is more expensive.

You discover the D-Link DP-311U's shortcomings immediately: It's the only device in this group that lacks a wizard-driven setup. Instead, you need to adjust your PC's IP address to be on the same subnet as the DP-311U—not ideal. But at least the process is well described in the printed setup booklet. An included CD provides a dated-looking but mostly functional administration utility; oddly, though, Netware settings are included that the print server doesn't support.

After logging on to the management interface, users can configure basic network, wireless, and security settings, including either 64-bit or 128-bit encryption.

To configure your printers and the appropriate redirect port, you must rely on the Add Printer wizard in Windows XP; no setup utility is provided. The Win XP wizard works fine, but we would have preferred a dedicated application. Overall, the DP-311U is just an average print server.—OK

### Hawking HWPS12UG

\$130 street. Hawking Technology, www.hawkingtech.com. ●●●●○

Combining a comparatively comprehensive feature set, a great user interface, good 802.11g wireless performance, and a low price, the Hawking HWPS12UG handily earns our Editors' Choice.

This is the only device in our roundup with an Ethernet port for configuration, as well as two USB 1.1 ports and a parallel port, allowing you to connect up to three

## Hawking HWPS12UG



The Hawking HWPS12UG offers the best combination of features and performance, not to mention a relatively low price. Its ability to control up to three printers (two via USB and one via parallel) and its well-organized Web-based management interface won us over, as did its easy installation and strong, steady wireless range.

In a growing market that hasn't yet fully matured, the HWPS12UG has the most to offer a home or small office. Businesses looking for more security and wide-ranging protocol support, however, should consider the HP Jetdirect 380x.



printers simultaneously. Six status LEDs indicate power, LAN, WLAN, and all printer port activity.

We were especially impressed with the integrated wireless site-survey tool, which discovered more than ten wireless networks in our labs. The HWPS12UG is also the only device to include a DHCP server that can be activated if needed. Netware, SMB, and AppleTalk printing support and 64-bit and 128-bit WEP and SNMP are part of the extensive feature set as well.

Included with the installation CD are setup wizards for both the print server and the client-side port utility, which installs the appropriate redirect ports on your PC. For configuration and management, you

can use either the Web-based interface, which was the best we saw in this roundup, or an included Windows application.

The one feature we would have liked to see is some form of print queue display or management interface similar to that found in the Axis product. But this is hardly a deal breaker. The HWPS12UG has plenty going for it: notable features, solid performance, and an affordable price.—OK

### Linksys Wireless-G WPS54GU2

\$159 list. Linksys, www.linksys.com.

●●●○○

As the 54G and U2 in its model number suggest, the Linksys Wireless-G WPS54GU2 takes advantage of two high-speed tech-

## PERFORMANCE TESTS

For this story, we wanted to determine how far the wireless signals of the print servers could reach, and how fast they could execute print jobs. The wireless range is what set these devices apart; the differences in speed, for the most part, are insignificant.

We conducted the tests in our wireless testing lab, a 160-foot long, L-shaped office-building basement hallway 40 feet below ground. We placed a workstation with test files and an 802.11g access point in a conference room at the end of the hallway. We then placed a Samsung CLP-550 color laser printer on a Rubbermaid cart, along with the eight print servers, one by one. We tested each print server at 60 feet, 120 feet, and 160 feet from the workstation and access point.

Distance to printer (feet) ▶	Adobe Acrobat 5.0 (5-page PDF, text and graphics)			Adobe Photoshop 7.0 (1-page bitmapped image)		
	60	120	160	60	120	160
<b>HOME-/SMALL-OFFICE</b>						
<b>Axis OfficeBasic USB</b>	1:17	1:17	1:18	0:52	0:53	0:54
<b>Belkin F1UP001</b>	1:20	1:22	1:20	0:44	0:45	0:45
<b>D-Link DP-311U</b>	1:17	1:17	—	1:03	1:03	—
<b>Hawking HWPS12UG</b>	1:13	<b>1:13</b>	1:27	0:43	0:42	0:43
<b>Linksys Wireless-G WPS54GU2</b>	<b>1:12</b>	1:14	<b>1:15</b>	<b>0:37</b>	<b>0:38</b>	<b>0:39</b>
<b>SMC EZ Connect SMC2621W-U</b>	<b>1:12</b>	—	—	0:42	—	—
<b>BUSINESS-CLASS</b>						
<b>HP Jetdirect 380x</b>	<b>1:12</b>	<b>1:13</b>	—	<b>0:39</b>	<b>0:40</b>	—
<b>TROY PocketPro USB</b>	1:27	—	—	1:30	—	—

RED denotes Editors' Choice. A dash indicates that the product could not receive the print job at this distance.

SUMMARY OF FEATURES

Print Servers

Download this table at [www.pcmag.com](http://www.pcmag.com)

■ YES □ NO	Axis OfficeBasic USB	Belkin F1UP001	D-Link DP-311U	Hawking HWPS12UG	Linksys Wireless-G WPS54GU2	SMC EZ Connect SMC2621W-U
Price	\$139 list	\$129.99 list	\$149 direct	\$130 street	\$159 list	\$99.99 list
Provides list of supported printers	■	■	□	■	■	■
Wireless standard	802.11b	802.11g	802.11b	802.11g	802.11g	802.11b
External/removable antenna	□ □	■ □	■ ■	■ ■	■ □	■ □
Internal memory buffer for printing	8MB	8MB	2MB	16MB	3MB	512K
Internal flash memory for firmware upgrades	2MB	2MB	512K	2MB	1MB	512K
<b>MANAGEMENT</b>						
Console/Web/proprietary management	□ ■ ■	□ □ □	□ ■ ■	■ ■ ■	□ ■ □	□ ■ □
SNMP management	■	□	■	■	■	□
Firmware updates through Web/TFTP	■ □	■ □	■ ■	■ □	■ □	■ □
Reset/print status button	■ ■	■ ■	■ □	■ □	■ ■	■ ■
<b>PROTOCOL SUPPORT</b>						
DHCP client/server	■ □	■ □	■ □	■ ■	■ □	■ □
TCP/IP / SMB / AppleTalk	■ □ ■	□ □ □	■ ■ ■	■ ■ ■	■ □ ■	■ ■ ■
NetBEUI/IPP/LPR	□ ■ ■	□ □ ■	■ ■ ■	■ ■ ■	■ ■ ■	■ ■ ■
<b>LED INDICATORS</b>						
LAN/WLAN	□ ■	■ ■	■ ■	■ ■	■ ■	■ ■
Activity/Error	■ □	■ ■	■ □	■ ■	■ ■	■ ■
USB	□	□	■	■	■	■
<b>PORTS</b>						
LAN	□	■	■	■	■	■
Parallel	□	□	□	■	■	□
USB 1.1 / 2.0	■ □	■ □	■ □	■ □	■ ■	■ □

RED denotes Editors' Choice.

nologies, 802.11g wireless and USB 2.0. It also excels in performance, topping all other products in five out of six tests. Still, it runs a little too high on price and short on features to earn our Editors' Choice.

This is the only device in our story to offer a high-speed USB 2.0 port. In addition, it includes a parallel port for printers without USB connectors. Both ports can be used at the same time, allowing you to share two printers on your network.

Configuring the Linksys with the step-by-step installation guide is easy and straightforward. Once configuration is complete, the Linksys print-driver setup utility must be installed—also painless. Unlike some print servers, such as the HP Jetdirect 380x, the WPS54GU2 does not let you configure your printer's drivers on the fly; you have to install all drivers in advance. Assigning existing printer drivers to one of the two Linksys ports is easy, though. You can print a status page by pressing the Reset button.

Surprisingly, the Web interface is virtually identical to that of the SMC EZ Connect Wireless Print Server SMC2621W-U. Aside from cosmetic graphical differences, all features, configuration, and status components were the same.

The wireless range of this print server is undoubtedly impressive, as is the inclusion of USB 2.0. But the low price and features of the Hawking device give it the edge.—OK

**SMC EZ Connect Wireless Print Server SMC2621W-U**

\$99.99 list. SMC Networks Inc., [www.smc.com](http://www.smc.com).

●●○○○

We cannot recommend the SMC EZ Connect Wireless Print Server SMC2621W-U to anyone because of its poor wireless range—it barely reached the 90-foot marker of our test area—and other shortcomings. This no-frills 802.11b wireless print server has just one Ethernet port for wired connectivity and one USB 1.1 port to connect a single printer.

The included installation wizard is primitive too, and many portions of the text seem to have been hastily translated into

English. We also disliked the WEP key entry field, which offers no help regarding the length and format of the WEP key strings.

After configuring the print server, the wizard proceeds with installation of the printer driver utility and creates the appropriate port in Windows to communicate with the server.

All subsequent configuration must be done through the Web-based user interface, which closely resembles that of the Linksys print server. You can configure basic network and wireless settings, including WEP keys; retrieve status information; and configure AppleTalk or IPP. But apart from this versatility, the configuration tools, like the other features, are unimpressive. Add to that the EZ Connect's poor performance, and you will be better off looking elsewhere for a print server for your home or small office.—OK

**MORE ON THE WEB**

Check out [www.pcmag.com](http://www.pcmag.com) for detailed photos of the products reviewed in this story, as well as additional testing information.

**OUR CONTRIBUTORS**

**Craig Ellison** is the director of operations at PC Magazine Labs. Associate editor **Davis D. Janowski** and PC Magazine Labs lead analyst **Oliver Kaven** were in charge of this story.



Stacey Harnick  
212-503-5106

Kathy Rosa  
212-503-4847

Christopher Thornton  
212-503-5067

## MarketLink Sales 1-877-267-2315

2 GM Corp.	www.abledesigner.com	126	Foxconn	www.foxconnchannel.com	120
Aberdeen Inc.	www.aberdeeninc.com/mag	118	FragBook	www.falcon-nw.com	127
Alan Broadband Company	www.zapchecker.com	126	Inkfarm	www.inkfarm.com	121
Bason Computer	www.basoncomputer.com	117	Jotto Desk	www.jottodesk.com	119
BenQ	www.pcmall.com	117	Logicube	www.logicube.com	123
Blue Genesis	www.bluegenesis.com	123	Netc	www.netclabels.com	121
Broadway Photo	www.bwayphoto.us	119	Powerleap	www.powerleap.com	119
Capitol College	www.capitol-college.edu	124	Princeton Disc	www.princetondisc.com	121
CyberGuys	www.cyberguys.com	121	Simple Servers	www.simpleservers.com/pcmag	124
dotAmerica.com	www.dotamerica.com	126	Steinhausen	www.steinhausen.com	125
ECAB	www.ecabengraving.com	126	Susteen	www.datapilot.com	122
Ei Printing	www.checksforless.com	121	Trilogy	www.partslistsoftware.com	126
ESS Data Recovery	www.savemyfiles.com	124	Visitech	www.visitech.biz	124
Fat Cow Web Hosting	www.fatcow.com/how	123			

Thousands of items in stock!  
New/Used/Refurbished  
Call us today!



We repair tape drives, too

<b>HARD DRIVES</b>	<b>TAPE DRIVES</b>
<b>USB/FIREWIRE DRIVES</b>	<b>TAPE LIBRARY</b>
<b>POCKET DRIVES</b>	<b>TAPE MEDIA</b>
<b>SAN</b>	<b>LAPTOPS</b>
<b>RAID ARRAYS</b>	<b>...and more</b>

SCSI • IDE • NOTEBOOK • FIBRE CHANNEL  
DLT • ULTRIUM • DAT/DDS • AIT

DELL
IBM
HEWLETT  
PACKARD
Quantum
TOSHIBA

SONY
Seagate
FUJITSU
HITACHI
Maxtor

Bason Computer Inc.

818-725-9704 • www.basoncomputer.com

### The DLP™ Collection, A Projector for Everyone.

**benq** 

**PB6100**

- Home Theater/Office
- 1080 Lumen Super Bright by AI Applications
- 2000:1 Ultra High Contrast Ratio
- Optical Zoom Lens - 10x Digital Zoom
- 107TV Compatible - 720p, 1080i, 480p
- PC/Mac/Video/i-Share
- 6:35:5 Screen Ratio Selection
- 80" to 210" Screen Size
- 3000 Hours Lamp Life\*\*
- Always Quiet. Less Than 31 dB

**\$899\***

**benq** 

**PB6200**

- Office/Home
- 1780 Lumen Super Bright by AI Applications
- 2000:1 Ultra High Contrast Ratio
- Native 1024x768 Support up to 1380x1024
- Colorful Zoom Lens - 10x Digital Zoom
- PC/Mac/Video/i-Share
- 107TV Compatible - 720p, 1080i, 480p
- 40" to 200" Screen Size
- 3000 Hours Lamp Life\*\*
- Light Weight Only 5.5 lbs

**\$1,399\*\***

Every BenQ projector includes a DLP™ Chipset that ensures high-quality, digitally based images that won't fade or degrade over time. Add with our 3-year warranty and 1st year QXchange policy, it's fast and easy to get a new projector should you need a replacement!

PC Mall

1-888-978-6706  
www.PCMall.com

**benq** 

**PB7200**

- Conference Room/Home
- 2000 Lumen, 2000:1 Contrast Ratio
- Native 1024x768 Support up to 1380x1024
- Optical Zoom Lens - 10x Digital Zoom
- 107TV Compatible - 720p, 1080i, 480p
- 2 PC inputs, PC/Mac/Video, PIP
- Intelligent Remote Control
- 34.8" Whisper Quiet
- Throw Ratio: 0.7 @ 9.9'
- Dynamic Color Management System
- Compact and Light Weight, 5.5 lbs

**\$1,699\***

BenQ

\*Price after \$100 mail-in rebate. Rebate valid from 8/1/04 - 8/31/04  
 \*\*Price after \$200 mail-in rebate. Rebate valid from 8/1/04 - 8/31/04  
 \*\*\*Economy Mode: 3000 hours, Standard 2000 hours  
 Under normal operating conditions the DLP™ Imaging device lifetime exceeds 100,000 operating hours  
 Mention Code: ZPC10B

# SCALING NEW HEIGHTS IN SCALABLE STORAGE

Aberdeen, the innovator of incredible storage solutions, is proud to introduce the XDAS. The highly scalable XDAS provides a flexible framework for building and managing cost-effective SATA RAID storage systems. Each scalable XDAS box packs a whopping 3 Terabytes in a standard 2U format. Bundled with either an Aberdeen Stirling server or AberNAS solution, the XDAS delivers additional scalable storage space of up to 15TB per SCSI port.

The expandable, dense storage capacity of the XDAS provides for dependable storage and can be deployed easily via any external SCSI port thus allowing a seamless integration into your existing IT infrastructure. Among the innovative features setting XDAS apart from the field are host and OS independence, dual host failover clustering capability and an optional fibre channel interface allowing its placement to be literally miles away from the server.

Give us a call and one of our expert system consultants will help you determine which solution best fits your needs, or visit our website, [www.aberdeeninc.com](http://www.aberdeeninc.com), to view more detailed specs of this revolutionary product. Our industry-leading 5-Year Warranty reduces cost of ownership and provides peace of mind. See why Fortune 500 companies such as Agilent, Boeing, Lockheed Martin, Motorola and Northrop Grumman have chosen Aberdeen, the Custom Server Solution Provider.



## ABERDEEN XDAS

### Direct Attached Scalable Storage 2U SATA-to-SCSI RAID

- **3TB of Direct Attached Storage**
- Daisy Chain Units for Scalability
- OS and Host Independent
- Supports Dual Host for Server Failover Clustering
- 2 SCSI Host Channels
- 12 x 250GB 7200 RPM Hot-Swap SATA Hard Drives
- Intel® 80321 I/O Processor
- Modular/Cableless internal design
- RAID Controller Smart LCD Display
- RAID level 0, 1, 3, 5, 6, 10, JBOD
- HotSpare, HotSwap & Auto-Rebuild
- Multiple RAID arrays/LUNs
- Fast RAID Initialization and Fast Rebuild process
- Dual Flash ROM for Redundant Firmware Images
- RJ-45 LAN port & RS-232 for setup & management
- Optional Fibre Channel Interface
- **5-Year Limited Warranty**

**\$8628**

## ABERDEEN STIRLING S13

### 1U Rackmount Server XDAS Scalable Controller

- **Connect up to 10 Aberdeen XDASs**
- **Up to 30TB of Scalable Attached Storage**
- Supermicro P4SC8 with Intel® E7210 Chipset
- Intel® Pentium 4® Processor 2.4GHz 800MHz FSB
- 1GB CL2 DDR400 SDRAM (Up to 4GB)
- Integrated Adaptec Dual-Channel Ultra320 SCSI Controller for up to 5 Aberdeen XDASs
- External SCSI port for easy connection to XDAS
- Optional SCSI Controller for up to 10 Aberdeen XDASs
- Integrated SATA/150 RAID Host Controller
- 2 x 80GB 7200 RPM Hot-Swap SATA Hard Drives
- Upgradeable to 500GB of Hot-Swap Host Storage
- Dual Integrated Intel® Gigabit® for Network Teaming
- **5-Year Limited Warranty**

**\$1911**

- Add **\$8628** for each 3TB Aberdeen XDAS
- Scalable AberNAS Version Available

## ABERDEEN STIRLING S33

### 3U Rackmount Server XDAS Scalable Controller

- **Connect up to 25 Aberdeen XDASs**
- **Up to 75TB of Scalable Attached Storage**
- Supermicro X5DP8-G2 with Intel® E7501 Chipset
- Dual Intel® Xeon® Processors 2.4GHz 533MHz FSB
- 2GB ECC Registered DDR SDRAM (Up to 16GB)
- Integrated Adaptec Dual-Channel Ultra320 SCSI Controller for up to 5 Aberdeen XDASs
- External SCSI port for easy connection to XDAS
- Optional 4 SCSI Controllers for up to 25 Aberdeen XDASs
- 3Ware 8506 8 port SATA RAID Controller
- 2 x 80GB 7200 RPM Hot-Swap SATA Hard Drives
- Upgradeable to 1.75TB of Hot-Swap Host Storage
- 2 Integrated Intel® Gigabit® NICs
- Dual Integrated Intel® Gigabit® for Network Teaming
- **5-Year Limited Warranty**

**\$4699**

- Add **\$8628** for each 3TB Aberdeen XDAS
- Scalable AberNAS Version Available

Intel, Intel logo, Intel Inside, Intel Inside logo, Celeron, Intel Xeon, Itanium, Pentium and Pentium III Xeon are trademarks or registered trademarks of Intel Corporation. pr029

**888-453-0707**  
[www.aberdeeninc.com/mag](http://www.aberdeeninc.com/mag)

# Upgrade your Processor

It's easier than you think



Visit [www.powerleap.com](http://www.powerleap.com) and Click on InSPECS  
Our Patent Pending software will recommend the right upgrade for you.  
It doesn't get any easier than that!

1-866-PL-SALES  
**PowerLeap**

# JOTTO DESK®

2004 CELEBRATING OUR 10TH YEAR

## Vehicle Mounting Solutions

- Truly universal to all computers and vehicles
- Do-It-Yourself installation
- Removes in seconds

**Dealer inquiries welcome**

For more information, please call  
**1.877.455.6886** [www.jottodesk.com](http://www.jottodesk.com)

Jotto Desk® is a patented product and registered trademark of Assembled Products™ Corporation

# Broadway Photo

2922 Ave. L, Brooklyn, NY 11210  
**1-800-514-0163**

Hours: M-Th: 9am-10pm • F: 8am-4pm • Su: 10am-7pm • Sa: CLOSED

Visit our website at: [www.bwayphoto.us](http://www.bwayphoto.us)

We specialize in Overnight Delivery.  
Place Your Order by 7:00 PM EST  
and Receive Your Order by the Next Business Day!  
For an Additional \$29.95

Customer Service: 718-338-3028  
Local & International: 718-338-1800  
24 Hour Fax Hotline: 718-338-3029  
Email: [info@bwayphoto.com](mailto:info@bwayphoto.com)

• 21 Day Satisfaction  
• Next Day Air Available  
• Worldwide Shipping  
• No Surcharge on Credit Cards  
• Government & School PO's Accepted



## DIGITAL CAMERAS

### NIKON Coolpix 8700

- 4x Opti/4x Opt. Zoom
- 1.8" LCD

**\$669<sup>99</sup>**  
NEW! Coolpix 2200... \$109.99  
NEW! Coolpix 3200... \$189.99  
NEW! Coolpix 4200... \$289.99  
NEW! Coolpix 5200... \$359.99

### OLYMPUS C-8080

- 8.0 MegaPixels
- 3x Optical Zoom

**\$649<sup>99</sup>**  
C-740... \$239.99 C-750... \$339.99  
C-765... \$329.99 C-770... \$394.99  
C-5000... \$234.99 C-5000... \$414.99

### SONY Mavica CD-500

- 5.0 MegaPixels
- 2.5" LCD Screen

**\$419<sup>99</sup>**  
Mavica CD-250... \$389.99  
Mavica FD-200... \$254.99

### CANON Powershot PRO 1

- 6.0 MegaPixels
- 7x Optical Zoom

**\$689<sup>99</sup>**  
S410... \$299.99 S500... \$359.99  
A80... \$244.99 S115... \$304.99  
A73... \$129.99 A310... \$139.99

### MINOLTA Dimage A2

- 8.0 MegaPixels
- 7x Optical Zoom

**\$669<sup>99</sup>**  
A1... \$479.99 XT... \$154.99  
G414... \$189.99 X6... \$214.99

### NIKON D70

- 6.1 MegaPixels
- 4x Digital Zoom

**\$779<sup>99</sup>**  
D70 KIT... \$1079.99  
D2H... \$249.99 D2X... CALL  
D100... \$1149.99 D1X... \$2519.99

### OLYMPUS E-1

- 5.74 MegaPixels
- 10x Opt/1x Dig. Zoom

**\$1069<sup>99</sup>**  
E-20... \$880.99 E1... \$1,414.99  
O-S80... \$219.99 C-60... \$319.99

### SONY CyberShot DSC-V1

- 6.0 MegaPixels
- 4x Digital Opt. Zoom

**\$364<sup>99</sup>**  
DSC-P73... \$239.99 DSC-P72... \$279.99  
DSC-P100... \$314.99 DSC-W1... \$339.99  
DSC-T11... \$484.99 DSC-T1... \$381.99

### CANON Digital Rebel Kit

- 6.3 Mega Pixels
- 10x Dig. 7x Opt. Zoom

**\$719<sup>99</sup>**  
Digital Rebel... \$629.99  
G5... \$404.99 EOS 10 Mark II... \$404.99

### MINOLTA Dimage Z2

- 4.0 MegaPixels
- 10x Opt/4x Dig. Zoom

**\$294<sup>99</sup>**  
NEW! Z1... \$234.99  
NEW! Z1... \$234.99  
NEW! G600... \$319.99  
NEW! Maxxum 7 Digital... CALL

### NIKON Coolpix 5400

- 5.1 MegaPixels
- 4x Digital Zoom

**\$404<sup>99</sup>**  
Coolpix 4000... \$319.99  
NEW! Coolpix 3700... \$229.99  
NEW! Coolpix 5700... \$429.99

### SONY DSC-R26

- 19" LCD Screen
- 7x Opt/4x Dig. Zoom

**\$689<sup>99</sup>**  
DSC-R717... \$874.99 DSC-T11... \$309.99  
DSC-P95... \$219.99 DSC-P10... \$299.99

### CANON EOS 10D

- 6.3 MegaPixels
- 1.8" LCD Screen

**\$1099<sup>99</sup>**  
10D... \$549.99  
SD10... \$249.99 SD110... \$209.99

### PENTAX Optio 555

- 5.0 MegaPixels
- 5x Optical Zoom

**\$364<sup>99</sup>**  
S41... \$269.99 S40... \$219.99  
S3100... \$209.99 1ST Dig... \$979.99

### FUJI Fine Pix S7000

- 3224x2016 Resolution

**\$389<sup>99</sup>**  
NEW! F710... \$324.99  
NEW! i828 Pro... \$479.99  
S3000... \$229.99 S3000... \$189.99  
S2... \$1299.99 S3... CALL

## DIGITAL VIDEO

### CANON GL-2

- 20x Optical Zoom
- 100x Digital Zoom
- 2.5" LCD Screen
- IEEE 1394

**\$1479<sup>99</sup>**  
NEW! Optima 200 MC... \$699.99  
NEW! Optima 30... \$729.99  
NEW! Optima 30... \$579.99  
NEW! Optima-40... \$629.99

### JVC GR-HD1

- 1.8 MegaPixels
- 20x Digital Zoom

**\$1849<sup>99</sup>**  
NEW! GR-DX77... \$369.99  
NEW! GR-D057... \$404.99  
NEW! GR-D0307... CALL  
NEW! GR-DV3000... \$739.99  
Special: GV-DV300... \$1509.99  
GV-DV5000... \$2499.99  
NEW! JV-HD100... \$799.99

### SONY DCR-DVD201

- 10x Opt/120x Dig. Zoom
- 2.5" LCD Screen

**\$699<sup>99</sup>**  
NEW! DCR-DVD101... \$599.99  
NEW! DCR-IP1... \$729.99  
NEW! DCR-IP55... \$689.99  
NEW! DCR-IP220... \$759.99  
NEW! DCR-PC230... \$949.99  
NEW! DCR-PC100... \$609.99

### CANON XL-1S

- 3 CCD
- 7" Color LCD

**\$2669<sup>99</sup>**  
NEW! Elura 68... \$174.99  
NEW! Elura 68... \$454.99  
NEW! Elura 76... \$494.99  
NEW! ZR90... \$289.99  
NEW! ZR85... \$334.99  
NEW! ZR90... \$399.99

### SONY DSR-PD170

- 1.0 MegaPixels
- 12x Optical Zoom
- 1.8" LCD

**\$2469<sup>99</sup>**  
Special: DSR-PDX10... \$1499.99  
Special: DSR-TRV960... \$1249.99  
NEW! DHR-1000... \$2979.99

### PANASONIC PV-GS200

- 19x Opt/120x Dig. Zoom
- 2.5" LCD

**\$604<sup>99</sup>**  
NEW! PV-G99... \$294.99  
NEW! PV-G512... \$399.99  
NEW! PV-G514... \$329.99  
NEW! PV-G515... \$309.99  
NEW! PV-G355... \$489.99  
NEW! PV-G5120... \$489.99  
NEW! PV-G5000... CALL

### PANASONIC AG-DWX100A

- 3-CCD Imaging
- 10x Optical Zoom

**\$2579<sup>99</sup>**  
NEW! AG-DV2600... \$1799.99  
NEW! AG-DV500... \$719.99  
NEW! AU-DVC30... \$1649.99  
NEW! PV-DV72... \$489.99  
NEW! PV-DV593... \$749.99  
NEW! VDR-M90... \$599.99  
NEW! VDR-M70... \$529.99

Policy: Visa, MasterCard, Discover, American Express, Novus, Citicard, Money Order, Certified Check, International (limit up to \$10,000) with name and address stamped on check. C.O.D. orders are also accepted. Orders by mail please print name address and phone number clearly. Shipping available in the Continental U.S.A. will be via 1-day, 2-3 day or Air Mail. Over size items via track. Shipping and Handling fee additional. 21 days for return of unopened video & digital. 2 days for return of unopened audio. Full customer service for returns and exchanges. Shipping and Handling fee not refundable. All returns are subject to a minimum restocking fee of 10%. Prices may reflect mail orders. All returned merchandise must be in new condition and must include all packaging and printed materials. In case of a product defect, immediate contact. Payment Plans: In-store financing for 12000+ total amount. Finance plan are subject to change. Please check our website for current prices. All items are available by USA, International or Broadway Photo and Video. All our merchandise is brand new and factory fresh. Quantities are limited. Thank you and enjoy your order.

C:\&gt;explore\_foxconn\_



## 925 chipset

Intel P4, Socket 775  
800MHz front side bus  
Integrated Gigabit LAN



## 915 chipset

Intel P4, Socket 775  
800MHz front side bus  
7.1 channel High Definition audio



## Chimaera

SPI 400W, UL/FCC  
ATX and microATX capable  
USB 2.0 & IEEE-1394 front ports



## miniPC coming soon

7-in-1 card reader  
WLAN and TV tuner option  
Media center

## CMI-P5-1C

Copper core, radial fin  
Temperature-controlled fan  
Prescott-T 775 CPU



## CMA-K81CN-C

AMD Approved for K8/Athlon 64/Opteron  
Nickel-plated copper  
Temperature-controlled fan



mwave.com

A FAMILY LINE OF PRODUCTS

[www.foxconnchannel.com](http://www.foxconnchannel.com)

**FOXCONN**

Advancing Through Innovation

## CD & DVD Replication

From creating a dynamic multimedia presentation on CD, DVD or web, to custom printing and packaging, we are your total solutions provider!

- Mastering & Custom Presentations
- CD/DVD Duplication/Replication
- Printing & Packaging
- CD/DVD Copiers/Printers

**Princeton Disc**  
Since 1986

Call today!  
800.426.0247  
www.princetondisc.com

# got outlets?

**PROBLEM**

- Just plug those bulky adapters into the LIBERATOR and free up more outlets.
- Perfect for Home Theaters, Home Offices, Workstations, UPS systems, every room in your home or office.

**use ALL outlets with the LIBERATOR!**

**SOLUTION**

5 Pack of LIBERATORS 121 2535  
**\$8.95**

Use Keycode S4H3503 when ordering and get your FREE 180 page Cyberguys® catalog packed with over 3,000 great products!

**CYBERGUYS!**

**ORDER NOW!**  
Call 800-892-1010 or go to [cyberguys.com](http://cyberguys.com)

**PC MAGAZINE** **MarketLink**

## Generate More Sales.

Put Your Ad Here.

**Call Now 1-877-2315**

## Instant media barcode labels- just add a **PRINTER!**

Become a "media barcode label expert" in minutes!

Netc Label System 5.0 works right out of the box.

- Predefined Netc Label Jobs
- Predefined Netc Label Templates
- Predefined Netc Color Palettes
- Superior Quality Netc Label Stock

• [www.netclabels.com/freedemo](http://www.netclabels.com/freedemo)

**Netc**  
www.netc.com  
"The Media Barcode Label Experts™"

P.O. Box 320784 Fairfield, CT 06825  
phone: 203.372.NETC(6382)  
fax: 203.372.0676 www.netclabels.com

# CHECKS

Guaranteed Lowest Prices In the Nation

- Quick production
- Low cost shipping
- Free logo imprinting
- Many colors and styles available
- Guaranteed software compatibility (including QuickBooks, Quicken & Peachtree)

call: 800.245.5775  
fax: 800.893.0177  
info@checksforless.com

Catalog available, featuring:  
laser checks • software forms • stationery  
deposit slips • security deposit bags

The FastTrack in Printing Company

[www.checksforless.com](http://www.checksforless.com) **EiPrinting**

## WHILE SUPPLIES LAST!

Qty 2+: **\$9.99!** Qty 1: \$10.99

Remanufactured HP 51645a (No. 45) cartridge.

more great deals at...  
**1-800-INKFARM**  
**inkfarm.com**  
the ink & toner supersite.™

Networking/Routers/Hubs • Printing/Paper/Supplies • Business Utilities/Financial

# Click. Sync. Done.

**UNIVERSAL KIT**

Phone List Under Flap

**DATAPILOT** [www.datapilot.com](http://www.datapilot.com)

**USB**

## Cell Phone Data Transfer Suite

**UNIVERSAL KIT SUPPORTS:**

- Motorola
- LG
- Samsung
- Sanyo
- Nokia
- Sony Ericsson

DataPilot interfaces with:

- Microsoft Outlook
- Outlook Express
- Palm® Software

Phone Book Manager

Internet Data Connect

Ringtone Composer

Image Editor

SMS Manager

Calendar - NEW

**susteen**

**20% OFF all Kits**

Shop [www.datapilot.com](http://www.datapilot.com)

Enter Promo Code: 555

Offer valid 8/1/04 - 8/31/04

**susteen**

# Lightning Fast Hard Drive Duplication & Back-up... Now Through USB!



## integrated keypad:

- ⊗ edit volume labels & partition names
- ⊗ enter supervisor passwords
- ⊗ customize unit behavior
- ⊗ store pre-defined settings



hard drive fits inside (cut-away view)  
13 oz. system



## the new Solitaire Turbo™:

**Clone Windows XP (or any other operating system) in less than 30 seconds!**

Quickly build, manage and duplicate any hard drive running any OS, right through the USB port, IDE interface or PCMCIA slot.

- ⊗ lightning fast duplication- nearly 2 GB/min.
- ⊗ clone through USB port at speeds up to 700 MB/min.
- ⊗ manage, back-up and restore master drives through USB
- ⊗ save time and money (control licensing fees)

Ideal for On-Site Support Personnel, VARS, System Integrators, MIS & Field Service Engineers

## FREE

- Technical Support
- 1 Year Parts & Labor
- Software Upgrades



**USB**

## USB connectivity:

- ⊗ store/restore images to network server
- ⊗ modify contents
- ⊗ defragment master drive
- ⊗ reformat
- ⊗ manage partitions (w/ 3rd party software)
- ⊗ optional USB dongle allows for fast & easy cloning via USB 2.0 at speeds exceeding 700MB/min (150 MB/min. with USB 1.1)



www.logiccube.com toll-free: (888) 494-8832

# KICKASS SERVERS

**FOR \$69.99!**



## FREE 30-DAY TRIAL: VM Server

Host from 10 to 100  
Windows & Unix sites!

Enjoy the freedom to manage your own server and the comfort of knowing that your websites are running on our award winning clustered architecture. Let us take care of all the hardware and software while you concentrate your effort on what matters most: building websites and making more money!

Single domain hosting available for as low as \$6.99!

**Call TODAY! 1-866-258-3350**



- Award Winning Technology
- 24X7 Outrageous Support
- 99.9% Uptime guarantee
- NO SETUP FEES!

Check out our free demo at [BlueGenesis.com](http://BlueGenesis.com)

Only \$8<sup>25</sup> per month

# Anything Else is JUST Hosting!



Now including Brightmail Anti-Spam®, the industry's most accurate and easiest-to-use anti spam solution.

Only \$8<sup>25</sup> per month

## FatCow™

### The FatCow™

- 500 MB Disk Space
- 25 GB Monthly Data Transfer
- 100 Email Accounts
- WebMail
- Brightmail Anti-Spam®

### Including:

- Shopping Cart
- CGI, PHP
- Toll-Free Support
- Website Statistics
- Search Engine Tools

### MiniMoo

- Domain Name Parking
- 1 Email Account
- Brightmail Anti-Spam®
- Coming Soon Page
- \$20 Domain Names

FatCow™: The Smart Choice in Small Business Hosting Since 1998.

[www.fatcow.com](http://www.fatcow.com) / now

Toll Free 1.866.517.6484

Copyright © 2004 FatCow Web Hosting, LLC. Brightmail® is a trademark or registered trademark of Brightmail, Inc. In the United States or other countries, and in some other countries.

Mass Storage Devices • Web Hosting/E-Commerce/Online Services/Dedicated Servers

cutting-edge,  
real-time  
interactive learning

fully accredited

live audio lectures  
from the comfort  
of your home or office

# MASTER'S DEGREES ONLINE

In network security, computer science, electrical engineering, information architecture, information and telecommunications systems management, and business administration (MBA).

## CAPITOL COLLEGE

Engineering • Computer Sciences • Information Technologies • Business

888-522-7486 www.capitol-college.edu

# Hard Drive Problems?



Call ESS at 800-237-4200

- Affordable & reliable.
- Personalized customer service.
- Clients include Harvard, NASA, & Lockheed.

ESS DATA RECOVERY LABS

www.savemyfiles.com

# SIMPLE SERVERS

Quality Internet Services Since 1995

### FREE!

Domain Registration  
with Select Packages

### HOSTING PLANS

Windows starting at \$19.95/mo.  
Linux starting at \$8.95/mo.

CGI, PHP, FTP, Front Page, 250MB,  
100 Email Accounts, WebMail, MySQL

### DEDICATED SERVERS

Redhat Linux 9 \$99.95/mo.  
Windows 2003.NET \$149.95/mo.

Intel 2.4Ghz Pentium 4  
80GB HD, 512MB, 500GB Transfer



www.simpleservers.com/pcmag

Call (800) 400-6381

## Tired of Paying the High Cost of e-mail Licensing and Maintenance?

We have an easy to manage and affordable e-mail solution for you!



### Introducing The Visitech e-mail server appliance SBMS/256

- Works with Microsoft® Outlook, Microsoft® Outlook Express and all other popular POP3 e-mail programs
- Users can change their own passwords, aliases, forwarding and spam control using their web browser
- Virus detection, anti-spam, anti-spam relay, advanced diagnostics
- All the programming is done remotely using your web browser
- Send e-mail directly to the internet or to another e-mail server
- e-mail forwarding, store and forward, auto out of office reply
- Each user is allowed up to 100 megabytes of disk storage
- 16 alias names per user, 32 groups of 256 users
- Easy and intuitive system administration
- SMTP/POP3, DHCP compatible
- Unlimited domain names
- Free technical support
- 256 license free users
- Remote user support
- Data base backup
- 1-year warranty
- No Licenses

#### Performance

Based on a 15k e-mail message size  
51 messages/second  
3,031 messages/minute  
181,860 messages/hour  
4,364,640 messages/day  
65.47 gigabytes of e-mail traffic/day

#### Specifications

2 gigahertz Intel® processor  
256 megabytes RAM  
40 gigabyte hard drive  
10/100MB Network Interface



\$2195

Other Models Available



WWW.VISITECH.BIZ (603) 679-1304 8am - 6pm EST

Enter to win a free SBMS/256 e-mail Server Appliance Visit WWW.VISITECH.BIZ





1923WATCH.COM

"I collect timepieces. When I received my Steinhausen, I knew from the look, feel, and quality of the watch that this would be one of my favorites. I have spent thousands of dollars for inferior watches. It will be my gift of choice this holiday season."  
Sol S., Mt. Vernon, NY

# So rare that only a handful were made in 1923

In 1923, a Swiss watchmaker crafted the most advanced watch of its time. After 80 years, the Steinhausen watch has finally been "reborn," preserving its mastery of technology and classic design. Once only displayed in high priced collections, this rare timepiece from history can now be yours.

**S**tep back in time to Steinhausen, Switzerland circa 1923. A master watchmaker works for months, trying to create the world's most perfect watch. Finally he succeeds—the first of its kind to display the date, day and month, and the only one to designate AM/PM.

### Collectors Pay Thousands \$\$\$\$

He makes a limited number of these distinctive handmade timepieces, which eventually find their way onto the wrists of only the world's most distinguished gentry. Today, collectors are willing to pay thousands of dollars to add one of these original Steinhausen masterpieces to their own collection.

### Reborn After 80 Years

Until now, that was the only way you could own a Steinhausen, still one of the world's rarest and most prized wristwatches. But for the first time in 80 years, the original Steinhausen masterpiece is now being painstakingly reproduced for modern day collectors. Still manufactured by hand, this 21st-century reproduction carries the same graceful styling and features as the original. The scratch-resistant crystal comfortably rests in a surgical grade stainless steel case and bezel, which provides the ultimate in precision and protection.

### Powered by You

This handsome timepiece has been updated with a kinetic automatic movement that is powered by the motion of the wearer's arm, so the watch never needs winding or batteries.

### Hand-crafted Elite Movement

The Steinhausen movement consists of 185 parts, that are assembled entirely by hand. To prevent wear on gears, fine watches use tiny gemstones to reduce friction. The Steinhausen features up to 35 jewels, 15 more than most of the world's elite watches. The movement is then rigorously tested for flaws and accuracy. Only 6% of the movements made ever meet the stringent requirements to be placed in this noble timepiece, making the Steinhausen one of the most accurate in the world.

### Adapted from Swiss Technology

A Swiss engineered movement comparable to the Steinhausen has never been produced at this low price. Each watch comes housed in a handsome storage case and includes two interchangeable leather wristbands in black and brown.

### \$14.95 "Wear It and Love It" Trial Offer

Until now, most of us couldn't afford an original 1923 Steinhausen. For a limited time though, the manufacturer has decided to offer this masterpiece of technology and design to watch lovers worldwide "risk free."

In fact, they are so confident you'll love the Steinhausen masterpiece, they want you to try it on your wrist for a full 30 days for only \$14.95 plus s&h. Experience this unparalleled value for thousands less than comparable collectable watches. If not satisfied, return the Steinhausen for a full refund of the trial fee.

**Steinhausen Classic**  
30 Day Trial Offer for Only \$14.95+ (s&h)  
Mention Promotional Code PC12403

To order call toll-free 24 hours a day!

**1-800-670-1217**

To order by mail, please call for details.



**SteinhausenDirect**

Mastering Technology & Classic Design  
3400 South Crater Road • Petersburg, VA 23805

### THE STEINHAUSEN REBORN

Old world craftsmanship & new world technology

- Transparent rear crystal displays movement.
- Kinetic movement—requires no battery or manual winding.
- 185 precision parts assembled by hand.
- Interchangeable 8.25" leather black or brown bands.
- Handsome Storage Case.
- Polished stainless steel construction.
- Water resistant to 50 meters.

*Kinetic movement...never needs batteries... never needs winding!*

### THE HISTORY OF WATCH MAKING

1868	Steinhausen masterpiece is created	1st Automatic movement in a wrist watch	1953	Girard-Perregaux introduces the Swiss quartz watch	2003
Patek Philippe makes first wrist watch	1923	Lips produced the first battery powered watch	1966	Steinhausen masterpiece is reproduced for first time	

**dotAmerica.com** \$7<sup>95</sup> MO.  
Professional hosting made easy!

Free Setup  
Free Domain  
Free Site Creator  
Money Back Guarantee  
Buy 12 Months, Get 2 Free  
Buy 24 Months, Get 6 Free

MySQL, CGI, PHP  
.NET, ASP, Access  
50 GB Bandwidth  
1000 MB Storage  
1000 POP Emails  
24x7 Support

www.dotamerica.com 1.866.673.HOST

**Parts & Vendors™**  
For Engineers, Designers and Prototypers

Personal Parts List Manager and Vendor Database

Download a FREE Demo from:  
**www.partslistsoftware.com**

**Trilogy DESIGN™**  
200 Litton Dr. #330  
Grass Valley, CA 95945  
530-273-1985  
FAX 530-477-9106

**Web Design**  
www.Abledesigner.com

- Web design from \$49
- E-Commerce Package from \$500
- Free back office training
- Fast & reliable Service

**Web Hosting**  
www.2globalmart.com  
\$29.95/year with 150 MB web space

**Call Today!**  
877-628-9888

**WIRELESS INSTALLATION METER**  
ZAP CHECKER MODEL 270

For WLANs, WI-FI and SECURITY  
Ultra-Sensitive WI-FI Sniffer

- Optimizes Placement of Hubs
- Detects Hot and Cold spots
- Aims and Aligns Antennas
- Tests Xmitr / Antenna Output
- Locates Cable Leakage
- Measures Baseline RF Levels, Locates RFI Sources
- Identifies Hacker Sites and Helps Eliminate Them

\$329 w/ Log Periodic 1.8 - 4.5 GHz Antenna  
ALAN BROADBAND CO. (888) 369-9627 FAX (850) 369-3798  
**WWW.ZAPCHECKER.COM**

**Hot!** NEW INKJET INKS!

**FIRST EVER-UV TRI COLOR INVISIBLE INKS**

UNLIMITED USES FOR:  
SECURITY  
ADVERTISEMENT  
SPECIAL EFFECTS  
THE CREATIVE MIND!!!!

Order Online Today!!!  
Or call (310) 376-9006

WWW.ECABENGINEERING.COM

**PC Magazine MarketLink**

**Generate More Sales.**

Put Your Ad Here.

**Call Now**  
1-877-2315

Business Utilities/Financial • Data Conversion/Data Recovery • Web Hosting/E-Commerce/Online Services/Dedicated Servers

**FREE SETUP**  
Call 1-800-741-6813  
sales@olm.net

**Start a Website**  
for only \$5.95 with our  
Sunsational Summer Specials

- Web Based Email
- Virus Protection
- Easy Setup
- Fast Connections

**www.olm.net/info**

Free 24 Hour Support  
No-Risk Guarantee

**30 Day 100% Money Back Guarantee**

**In Business Since 1996**

Servers Domain Registration Ecommerce Web Hosting **OLM.net**

- ✓ Perfect LCD Screens - Guaranteed
- ✓ You Choose Your Custom Color of Auto Finish
- ✓ Custom Graphics and Artwork Available
- ✓ Black Ops™ Aluminum Carrying Case Included



1-888-FALCON-1  
www.falcon-nw.com

 **FragBook**  
BY FALCON NORTHWEST  
A Higher Definition of Notebook

Computer Systems ■ Notebooks ■ Palmtops

# AFTER HOURS

TECHNOLOGY ON YOUR TIME

## Cool School Tools

BY CAROL ELLISON

School bells are ringing for another generation growing up with the Game Boy, PS2, and Xbox. But parents who want to replace arcade action with learning are in luck: Educational game-playing devices are a big trend these days. Kids no longer need to be tethered to a desktop computer to practice their skills; they can take devices along with them and work in a little brain-training just about anywhere. (Our favorite, though, is the nonportable VTech V.Smile, which turns your TV into a teacher.) In addition to the gadgets, we take a look at some of the new software offerings that can help your kids learn.

### LeapFrog Leapster Educational Game Cartridges

The 18 new video cartridges for the handheld LeapFrog Leapster (“Gadget Mania,” December 9, 2003, page 120) are a lot more fun than flashcards. We looked at Leapster Interactive Video: The Letter Factory for ages 4 to 6, Dora the Explorer Wildlife Rescue for the same age group,



and SpongeBob SquarePants Saves the Day, which is not age-rated and will appeal to fans of all ages.

All feature reading and math exercises; Dora adds in science, social studies, and Spanish. Of the group, First Grade is the most comprehensive, with 70 well-designed drills that teach basic skills, ranging from

punctuation to subject-verb agreement and sorting to subtraction. Educationally speaking, SpongeBob’s drills are lighter-weight than the others—but kids will love the quips and gibes, which are as funny as those on the TV show.—CE

The Letter Factory, \$20 street. Others, each \$25. Also required: Leapster Multimedia Learning System, \$80 street. LeapFrog Enterprises Inc., [www.leapfrog.com](http://www.leapfrog.com). ●●●●○



### LeapFrog Turbo Twist Extreme

Built like a flashlight and just as rugged, this device delivers fun-filled drills wherever your kids carry it. They’ll appreciate the gaming action as they guide Turbo Monkey over crevices and under flying objects on a liquid-crystal window display, “slamming” correct answers to spoken problems. The unit comes with a cartridge that includes more than 400 workbooklike drills in math, spelling, science, and social studies. As kids score points, they earn keys that open

#### WHAT THE RATINGS MEAN

- EXCELLENT
- VERY GOOD
- GOOD
- FAIR
- POOR

## BRAIN-ENHANCING SOFTWARE

### Dragon Tales: Learn and Fly with Dragons

In Dragon Tales, kids apply basic math and logic skills—like sorting and matching colors, shapes, and sizes—as they help Cassie the Dragon’s brothers and sisters do good deeds and earn badges and toys to pay for flying lessons. Once airborne, they can go to the next level or return to DragonLand to practice skills or enter more flying races. There are 11 games in three separate adventures. Kindergarten to first grade.—CE

\$19.95 list. Scholastic Inc., [www.scholastic.com](http://www.scholastic.com). ●●●●○

### Encarta Reference Library Premium 2005

 New this year in our perennial favorite encyclopedia software is content for a younger crowd, ages 7 to 12. Encarta Kids offers narrated slide shows, word and category search, and fun elements like games and yucky pictures (grossest: horse teeth). Another new feature is Math Help Online, for high schoolers; you can search by textbook to find the very problems you’re trying to solve and get help working through them.

Finally, you can add an Encarta search bar to your desktop; if you enter a search term and like what it finds, you can launch the program from the bar. This title is one of the best homework helpers we can imagine.

—Carol A. Mangis

\$74.95 list. Microsoft Corp., [www.microsoft.com](http://www.microsoft.com). ●●●●●

### I SPY Spooky Mansion Deluxe

This game takes the familiar theme of finding objects in busy scenes to a haunted house, where kids must solve puzzles to escape. Once they’re out, a friendly skeleton invites them to the next level. Random games

with 39 riddles each make for hours of play; kids really need to use their thinking caps. You won’t find as much curriculum content as in other games, but the fun factor is powerful; you’ll enjoy yourself just as much as the kids, helping them with solutions.

Grades 1 through 6.—CE

\$19.95 list. Scholastic Inc., [www.scholastic.com](http://www.scholastic.com). ●●●●○

### Mia’s Language Adventure: The Kidnap Caper

Grandma Mimi has disappeared, and kids help Mia, the cute and courageous mouse, find her. The Mia series features truly fun, interactive adventures that educate along the way.

doors and win them titles such as Amazing Artist. Additional cartridges can be purchased separately. For first to fifth grades.—CE

\$34.99 list; cartridges, \$9.99 each. LeapFrog Enterprises Inc., www.leapfrog.com. ●●●●○

### Oregon Scientific Barbie B-Book Laptop, Hot Wheels Accelerator Electronic Learning Computer

The Barbie B-Book Laptop is pink and purple (naturally), and the Hot Wheels Accelerator has flame decals on its black case; both have true QWERTY keyboards. Each delivers 60 educational games (including ten in Spanish), and spoken instructions prompt kids to type the words and phrases they're taught. These devices are better suited for older children, as vocabulary exercises assume an understanding of vowels and word construction. Although some



play more like Wheel of Fortune-style letter-guessing games than vocabulary lessons, more substantive exercises are included, as are two-player games. For kindergarten and up.—CE

\$59.99 list (each). Oregon Scientific Inc., www2.oregonscientific.com. ●●●●○

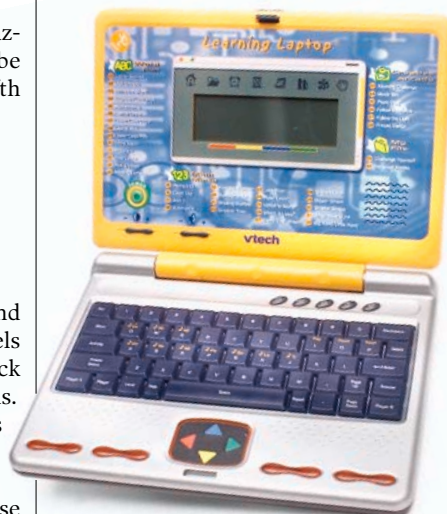

### VTech Learning Laptop

Kids can practice keyboarding skills on a QWERTY keyboard as they play the 38 learning games on the VTech Learning Laptop. It uses a gray liquid-crystal screen similar to that of the Hot Wheels and Barbie laptops; blocky graphics diminish the fun, but the excellent value makes up for that. The Laptop is rated for pre-K and kindergarten-age kids who are just learning to associate words with pictures. They might, however, be better off with colorful picture books, which pack more learning power and appeal for young readers. Ages 4 and up.—CE

\$30 street. VTech Electronics, www.vtechkids.com. ●●●●○

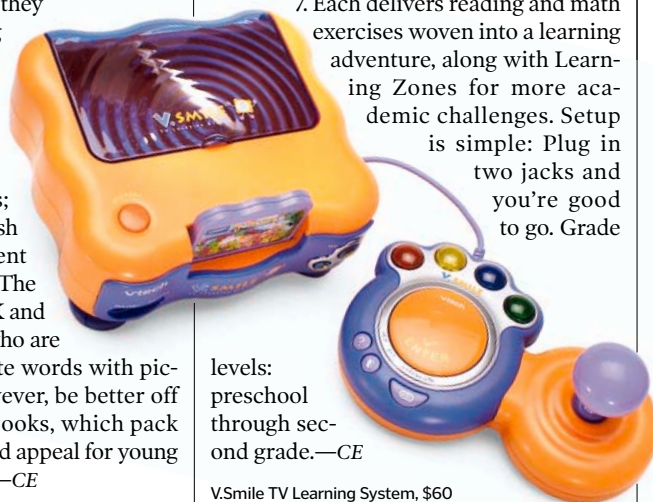

levels: preschool through second grade.—CE

V.Smile TV Learning System, \$60 street; Smartridges, \$20 each. VTech Electronics, www.vtechkids.com. ●●●●○

## MORE ON THE WEB

[www.pcmag.com/afterhours](http://www.pcmag.com/afterhours)

See After Hours online for more Quick Clips and Gear & Games reviews.

### VTech V.Smile TV Learning System and Smartridge Library

Kids acquire basic skills while playing games on the V.Smile TV Learning System, using a joystick or Enter key to choose the difficulty level and a one- or two-player game. The V.Smile comes with Alphabet Park, a single Smartridge (game cartridge) for early learners, preschoolers, and kindergarteners.

The console can scale to your kids' levels with ten additional cartridges (sold separately): the Junior Thinkers series for ages 4 to 6 and MasterMinds for ages 5 to 7. Each delivers reading and math exercises woven into a learning adventure, along with Learning Zones for more academic challenges. Setup is simple: Plug in two jacks and you're good to go. Grade

In previous titles, Mia covered math, science, and reading; now she's going global. Kids can begin to explore the French and Spanish languages in mini-games within the story. Parents may want to help younger kids get started, as game play can be a bit complex.—CAM

\$20 street. Kutoka Interactive, www.kutoka.com. ●●●●○

### SAT, PSAT, ACT 2005 Gold, Platinum

For 2005, Topics has updated SAT, PSAT, ACT—a Gold Edition three-CD set and Platinum Edition five-CD set—to reflect changes in the tests: Analogies will disappear and reading passages will be

shorter, but test takers will now have to write an essay. Serious students will opt for the Platinum edition and its two extra discs: One offers writing and vocabulary exercises to help with the essay portion of the test and the other gives tips and guidance on admissions and applying for scholarships, loans, and tuition assistance. Both editions feature more than 2,500 sample test questions and tutorials that guarantee a better score—or you'll get money back. So be sure to save your sales slip, discs, data files, and test scores.—CE

Gold, \$39.99 list; Platinum, \$49.99. Topics Entertainment Inc., www.topics-ent.com. ●●●●○

### Princeton Review SAT Preparation

With this new application from Vocol and The Princeton Review, SAT preparation can now accompany your kid anywhere—assuming you have the right phone and mobile service provider. Flash cards and minitests pop up in your phone's display window to drill kids on vocabulary, critical reading, sentence structure, grammar, arithmetic, algebra, and geometry. Answers in text explain what's correct and incorrect and, better yet, explain why.

Kids can schedule times for automated alerts; the phone

rings with new questions that are constantly refreshed by the service. Adults can ask to receive updates on how well their children are doing via SMS or the Web.

The tiny-screen format requires a lot of scrolling to read lengthy writing exercises, and other phone fun (photos, games, and old-fashioned conversation) could be distracting. But this is a great reinforcement tool, especially when used with other test-prep resources. Grade level: High school and up. Check with your mobile phone carrier to determine support.—CE

\$5.95 to \$12.95 per month, depending on carrier. Vocol, www.vocol.com. ●●●●○

# GEAR + GAMES



## Mousing Everywhere

For those of us who get impatient with laptop touch pads and pointing sticks, the ambidextrous BenQ M310 Wireless Optical Mouse has a terrific design for portability: The RF USB connector tucks right into the mouse when it's not in use. When you eject the receiver, the mouse powers on, and it turns itself off when you replace the receiver (you can also turn power off manually). The 800-dpi resolution makes the mouse responsive and accurate, and it works well on a variety of surfaces.—CAM

\$39.99 list. BenQ America Corp., [www.benq.com](http://www.benq.com). ●●●●○



## Small Wonder

The Creative MuVo Slim is the size of a business card, measuring only .3-inches thick and weighing just 1.2 ounces; you won't even know you're carrying it. Despite its size, the Slim holds 256MB of MP3 or WMA files, a voice recorder, an FM radio tuner with 32 presets, and a radio recorder. It connects via USB 2.0 and has a rechargeable lithium-ion battery that lasts up to 17 hours. The Slim worked perfectly in our testing, although the minimalist controls can be challenging.—Troy Dreier

\$199.99 list. Creative Labs Inc., [www.creative.com](http://www.creative.com). ●●●●○



## Fashion for Gadgets

Want to wrap your Blackberry, iPod, Treo, or other pricey handheld in something more elegant than pleather? Bellagio Designs makes device-specific cases out of real Italian leather that fit like, well, gloves. You can charge, change memory cards, and perform any other necessary functions without removing your device from its case. See the company's site for the models and colors available for your gadget.—CAM

\$27.99 direct and up. Bellagio Designs, [www.bellagiodesigns.com](http://www.bellagiodesigns.com). ●●●●○



## A Case of Style

The ultraquiet, illuminated Antec Aria case is a great way for do-it-yourselfers to build a small form factor (SFF) system. It's a marvel of industrial design, combining distinctive styling with a lift-out drive bay and removable side and top panels. Edges are smooth to reduce the risk of cuts. The case has a hefty 300W Antec power supply, two fans, an 8-in-1 card reader, four drive bays, three full-height PCI slots, and front-mounted USB 2.0, FireWire, and audio connectors. Best of all, unlike proprietary SFF cases, it can accept any standard MicroATX motherboard.—Don Labriola

\$130 street. Antec Inc., [www.antec.com](http://www.antec.com). ●●●●○

# Strategic Moves

BY PETER SUCIU

*"Strategy without tactics is the slowest route to victory. Tactics without strategy is the noise before defeat." The great military thinker Sun Tzu never played PC strategy games, but he would have made a challenging opponent. With this wave of new-release games, you can hone your skills as a PC desktop general.*

## Besieger

The land is divided and in chaos. Hideous monsters amass their forces as Viking and Cimmerian warriors prepare for battle. Through 12 enormous levels, you build and defend a mighty stronghold using more than 40 types of structures, and then bring the siege to your enemy's castles. Dynamic environments offer numerous options for massive citadels, and the photo-realistic landscape helps evoke an ancient age. Overly challenging game play and some silly mythical creatures clutter an otherwise grandly historical game.

\$29.99 list. Dreamcatcher Interactive Inc., [www.dreamcatchergames.com](http://www.dreamcatchergames.com). ●●●○○

## Ground Control II: Operation Exodus

If you don't feel like saving the universe by yourself, play through two linear-based campaigns over a LAN or in an Internet-based cooperative mode in this science fiction title. In addition to 24 single-player/co-op missions, Ground Control II features ten skirmish-mode maps for one-off engagements. Though the two opposing sides have unique units with special abilities, the game could use a bit more diversity to extend replayability. But with the numerous maps and immersive campaigns, chances are you'll be fighting for control for some time.

\$49.99 list. Vivendi Universal Games Inc., [www.vugames.com](http://www.vugames.com). ●●●●○

## Rise of Nations: Thrones and Patriots

Are you up to the challenge of guiding your people from the dawn of time to the space age, exploring the world, expanding your cities, and keeping the peace along the way? This ex-



RISE OF NATIONS

pansion of last year's smash hit adds six new playable powers, more diverse campaigns, and a new government option that lets you create a freedom-loving democracy or rule as a tyrannical dictator. Multiple modes of play allow for single-player real-time scenarios and turn-based campaigns to conquer the world, letting you savor each victory.

\$29.99 list. Microsoft Game Studios, [www.microsoft.com/games](http://www.microsoft.com/games). ●●●●●

## Spartan

This turn-based empire builder features more than 100 nations of the classic age, spanning Greece and the Near East. You must carefully manage resources, develop



SPARTAN

new technologies, and grow your cities, while erecting vast structures such as the Colossus and Oracle. As conquest is the key to victory, you'll have to create massive armies. But you don't have direct control over your men in the real-time battles. The turn-based aspects are winners, but the real-time aspects need some attention.

\$29.99 list. Graphsim Entertainment, [www.graphsim.com](http://www.graphsim.com). ●●●○○

## Warlords Battlecry III

When cultures meet, they often clash. But when entirely different species meet, total war results, as when human merchants encounter the snakelike Ssrathi. A campaign mode lets you plot your grand moves in distant lands; you can then jump into real time to fight individual battles. The game even offers role-playing, with an in-game hero to lead your army. Despite somewhat dated graphics, you'll be hard pressed not to hear this battle cry.

\$29.99 list. Enlight Software Ltd., [www.enlight.com](http://www.enlight.com). ●●●●○

## QUICK CLIPS

### Splinter Cell: Pandora Tomorrow

This game is not as clever or as moody as the original spy thriller. It's also not quite a sequel; the only notable changes are updated graphics and an addictive multiplayer mode, in which spies must complete their objectives while remaining undetected by mercenary opponents. Single-player mode is a bit short and unchallenging for veterans, but Pandora Tomorrow is still a head above most other new games. It's an enjoyable refresher for the upcoming Splinter Cell 3.—*Ari Vernon*



\$39.99 list. Ubi Soft Entertainment, [www.splintercell.com/us/home.php](http://www.splintercell.com/us/home.php). ●●●●○

### Nero PhotoShow Elite

This addition to the Nero product family packs an array of one-click photo and slide show capabilities behind a slick, friendly interface. Intuitive learning aids, navigation controls, and graphical tools

appear on most screens, but many features are self-explanatory.

PhotoShow's copious features are split into three areas: Manage (organize images, browse, and edit), Make (create Kodak prints, slide shows, mouse pads, and more), and Share (distribute images and slide shows online or on disc). The result is a remarkably easy-to-use package to complement Ahead's comprehensive Nero 6 digital media suite.—*Don Labriola*

\$49.99 list. Ahead Software Inc., [www.nerophotoshow.com](http://www.nerophotoshow.com). ●●●●○



### AstroPop

If your taste runs toward puzzles and arcade games, you can spend some happy hours with this new PopCap game. Play as one of three intrepid spaceship pilots (later you can unlock a fourth) and try to pop as many multi-colored bricks as possible without letting them fill the screen.



A light but cute story line propels you through increasingly difficult levels.—*CAM*

\$19.95 direct. PopCap Games, [www.popcap.com](http://www.popcap.com). ●●●●○

# BACKSPACE

TURN TO US WHEN YOUR COPPERTONE RUNS OUT

Edited by Don Willmott

**Entertainment Weekly**  
 Entertainment Weekly (subscription) - 4 hours ago  
 Courteney Cox is pregnant. Her rep confirms that she and David Arquette are expecting a child by Gary Susman ...  
[Friends star Cox expecting baby](#) BBC News  
[Courteney Cox Arquette Expecting a Child](#) ABC News  
[Reuters](#) - [FOX News](#) - [hellomagazine.com](#) - [NEWS.com.au](#) - [and 135 related »](#)



<< Wait a minute—does David know about Gary? (Google News)

>> The Wharton School's site teaches a powerful business lesson in positive reinforcement.

Well done!

Your password has been successfully changed.

You have every right to feel very proud of yourself.



CNN/Money: New \$50 bills unveiled - Microsoft Internet Explorer

**CNNmoney** New \$50 bills unveiled

View the back

Anyone can create one.

<< What an interesting potential use for Abode's top-notch document creation software! (Adobe ad on the CNN Money site)

>> But first you have to catch the gophers. (GopherCentral.com ad)

**MMMMmmmm... GOOD!**  
 Get different delectable recipes delivered via email by subscribing FREE to *The Daily Recipe*. Get Secret Recipes like: *WENDY'S Chili*, *Auntie Anne's Pretzels* & more from your friends at [GopherCentral.com!](#)  
[Click Here to Subscribe](#)

We apologize, but there are no **ERROR's** available at this time.

<< Oh, yeah? We spot at least one! (Universal Studios Florida site)

>> So powerful that it can lift off and fly around the room! (MCM Computers ad)



**ATX Mid-Tower Computer Case with 3000W Power Supply**

This case features removable side panels for easy access to motherboard and easy installation of expansion cards and drives.  
**Features include:** •Three 5¼" and two 3½" open drive bays and one 3½" internal drive bay •Seven expansion slots •Color coded I/O ports •Built-in



<< Faithful readers—and nappers—Dean and Benjamin Langfitt prove that *PC Magazine* can protect you from harmful UV radiation.

If your entry is used, we'll send you a *PC Magazine* T-shirt. Submit your entries via e-mail to [backspace@ziffdavis.com](mailto:backspace@ziffdavis.com) (attachments are welcome) or to Backspace, *PC Magazine*, 28 E. 28th St., New York, NY 10016-7940. Ziff Davis Media Inc. shall own all property rights in the entries.

Winners this issue: Joe Ganci, Dean Langfitt, Andrew Large, Michael Maker, Kirk McVey, Richard Smith, and Steve Worzman.

*PC Magazine*, ISSN 0888-8507, is published semi-monthly except 3 issues in November and monthly in January and July at \$39.97 for one year. Ziff Davis Media Inc, 28 E. 28th St., New York, NY 10016-7940. Periodicals postage paid at New York, NY 10016-7940 and at additional mailing offices. POSTMASTER: Address changes to *PC Magazine*, P.O. Box 54070, Boulder, CO 80328-4070. The Canadian GST registration number is 865286033. Publications Mail Agreement No. 40009221. Return Undeliverable Canadian Addresses to P.O. Box 503, R.P.O. West Beaver Creek, Richmond Hill, ON L4B 4R6, Canada. Printed in the U.S.A.



# CDW



## Color printing is finally affordable. Ladies and gentlemen, start your documents.

There's never been a better time to buy a color printer. The average cost has dropped 40% in the last several years while print speeds have increased 200%. And, as more and more companies choose color as a way to make documents stand out and make an impact, the ability to print in house saves money as well. CDW has more of the top brand color printers in stock. And, we have people dedicated to making sure you get the one that fits your needs.

So if you want the right printer at the right price, now's the right time.

THE RIGHT TECHNOLOGY. RIGHT AWAY.™  [CDW.com/PRINTEREVENT](http://CDW.com/PRINTEREVENT) • 800.399.4CDW

In Canada, call 800.387.2173 • [CDW.ca](http://CDW.ca)



To everyone who's been waiting for the right time  
to buy a color printer: Start shopping.



\*After e-bate; call your account manager for details. †Based on trading in a HP LaserJet 4500 printer in "good" condition; actual trade-in price may vary. Please visit [CDW.com/hptradein](http://CDW.com/hptradein) for a trade-in quote. ‡Bundle offer expires 10/03/04. Customer understands that CDW is not the manufacturer of the products purchased by customer hereunder and the only warranties offered are those of the manufacturer, not CDW. All pricing is subject to change. CDW reserves the right to make adjustments to pricing, products and service offerings for reasons including, but not limited to, changing market conditions, product discontinuation, product unavailability, manufacturer price changes and errors in advertisements. All orders are subject to product availability.



### hp Color LaserJet 3500N

- Up to 12ppm color/black and white
- 600dpi
- RAM: 64MB
- 45,000 page monthly duty cycle
- 1 year onsite standard warranty
- Network Ready



**\$999** CDW 574756  
**-233** ESTIMATED TRADE-IN\*  
**\$766** YOUR PRICE

Recommended supplies and accessories:  
 HP Print Cartridge Black **\$132.99** (CDW 578556)  
 HP Print Cartridge Color **\$129.99** (CDW 578560, 578561, 578562)  
 Network Cable **\$7.00**  
 HP Next Day Onsite 3 Year Warranty **\$559.99** (CDW 579343)

### XEROX Phaser 8400B Color Printer

- 24ppm color/24ppm black and white
- Up to 600x600dpi (2400 Fine Point)
- RAM: 124MB standard
- 85,000 page per month duty cycle
- Network Optional
- 1 year depot warranty standard

## XEROX

**\$999**  
CDW 563463



Xerox Genuine Solid Inks Black **\$64.99** (CDW 570058)  
 Xerox Genuine Solid Inks Color **\$99.99** (CDW 570102, 570108, 570109)  
 10/100 Base-TX Ethernet Interface **\$399.99** (CDW 586141)  
 Xerox 1 Year Onsite Warranty Upgrade **\$99.99** (CDW 570121)

**Free ink! \$115 value until 09/30/04\***



### Lexmark C510 Network Bundle

- 8ppm color/30ppm black and white
- RAM: 64MB
- 2400 image quality
- Network optional
- 1 year onsite warranty standard

## LEXMARK

**\$749**<sup>2</sup>  
CDW 587373

**Save \$79 with bundle purchase**

Bundle includes:  
 Lexmark C510 printer (CDW 585935) and  
 Lexmark NC4000E External Print Server (CDW 522898)

Recommended supplies and accessories:  
 High Yield Toner Cartridge Black **\$119.99** (CDW 585945)  
 High Yield Toner Cartridge Color **\$169.99** (CDW 585936, 585938, 585941)  
 Lexmark Additional 1 Year Extended Onsite Warranty **\$369.99** (CDW 205959)

THE RIGHT TECHNOLOGY. RIGHT AWAY.™ [CDW.com/PRINTEREVENT](http://CDW.com/PRINTEREVENT) • 800.399.4CDW

In Canada, call 800.387.2173 • CDW.ca