

QUESTION 1

If one of the links to a computer on a physical star topology is served, what will be the result?

- A.The entire network will stop working.
- B.The affected link and the adjacent network links will stop working.
- C.Only the affected link will stop working.
- D.Only the adjacent links will stop working.

Answer: C

In the star topology each computer is connected to a central point by a separate cable or wireless connection.

Thus

each computer has a dedicated link to the network central device and a break in the link between a particular computer

and the central network device will affect only that computer.

References:

David Groth and Toby Skandier,Network+ Study Guide(4th Edition), Sybex,AlamedaCA, 2005, pp. 1016.

QUESTION 2

When one connection to a host fails in a full mesh network, which of the following is true?

- A.All hosts can communicate
- B.No hosts can communicate
- C.Half of the host will lose communication
- D.Only the two hosts between the failed connection will lose communication

Answer: A

In a full mesh network, each node has a connection to at two other nodes. Thus, should one connection fail, it will have

no effect on communication as all nodes will be connected to at least one other node.

References:

David Groth and Toby Skandier,Network+ Study Guide(4th Edition), Sybex,AlamedaCA, 2005, pp. 1415.

QUESTION 3

Which of the following network topologies uses the most cable?

- A.Star
- B.Ring
- C.Bus
- D.Mesh

Answer: D

In the mesh topology, each node is connected to at least three other nodes. This requires more cabling than in the ring or

bus topology, in which each node is connected to only two other nodes, or the star topology, in which each node is

connected to a central hub or switch.

Incorrect Answers:

A:In the star topology, each node is connected to a central hub or switch. This requires less cabling than in the

mesh

topology, in which each node is connected to at least three other nodes.

B:In the ring topology consists of a closed loop in which each node is connected to the node ahead of it and the node

behind it in the loop. This requires less cabling than in the mesh topology, in which each node is connected to at least

three other nodes.

C:The bus topology is similar to the ring topology, except that the cable does not form a complete loop, but is terminated at each end. Each node, except the nodes at the end points, is connected to the node ahead of it and the

node behind it along the cable. This requires less cabling than in the mesh topology, in which each node is connected to

at least three other nodes.

References:

David Groth and Toby Skandier, Network+ Study Guide(4th Edition), Sybex, Alameda CA, 2005, pp. 5154.

QUESTION 4

Which of the following network topologies uses the least cable?

A.Star

B.Ring

C.Bus

D.Mesh

Answer: C

The bus topology consists of a single cable that connects the network nodes. Both ends of the cable are terminated just

after the last node. Each node, except the nodes at the end points, is connected to the node ahead of it and the node

behind it along the cable. This requires least amount of cabling.

Incorrect Answers:

A:In the star topology, each node is connected to a central hub or switch. This requires more cabling than in the bus

topology, in which the nodes are connected on a single trunk cable that is terminated just after the last nodes at either

end.

B:In the ring topology consists of a closed loop in which each node is connected to the node ahead of it and the node

behind it in the loop. This requires more cabling than in the bus topology, in which the nodes are connected on a single

trunk cable that is terminated just after the last nodes at either end and does not need to connect the ends together to

form a loop.

C:In the mesh topology, each node is connected to at least three other nodes. This requires more cabling than in the ring

or bus topology, in which each node is connected to only two other nodes, or the star topology, in which each node is

connected to a central hub or switch.

References:

David Groth and Toby Skandier, Network+ Study Guide(4th Edition), Sybex, AlamedaCA, 2005, pp. 5154.

QUESTION 5

Which of the following networking topology requires the MOST physical connections per node?

- A. Bus
- B. Ring
- C. Star
- D. Mesh

Answer: D

In the mesh topology, each node is connected to at least three other nodes. This requires more connections per node than in the ring or bus topology, in which each node is connected to only two other nodes, or the star topology, in which each node is connected to a central hub or switch.

Incorrect Answers:

A: In the star topology, each node is connected to a central hub or switch. This requires fewer connections per node

than in the mesh topology, in which each node is connected to at least three other nodes.

B: In the ring topology consists of a closed loop in which each node is connected to the node ahead of it and the node

behind it in the loop. This requires fewer connections per node than in the mesh topology, in which each node is connected to at least three other nodes.

C: The bus topology is similar to the ring topology, except that the cable does not form a complete loop, but is terminated at each end. Each node, except the nodes at the end points, is connected to the node ahead of it and the

node behind it along the cable. This requires fewer connections per node than in the mesh topology, in which each node

is connected to at least three other nodes.

References:

David Groth and Toby Skandier, Network+ Study Guide(4th Edition), Sybex, AlamedaCA, 2005, pp. 5154.

QUESTION 6

At which of the following speeds does token ring operate?

- A. 1 Mbps, 10 Mbps (Megabit per second)
- B. 1 Mbps, 4 Mbps (Megabit per second)
- C. 4 Mbps, 16 Mbps (Megabit per second)
- D. 10 Mbps, 100 Mbps (Megabit per second)

Answer: C

Token ring initially operated at 4 Mbps. This was later increased to 16 Mbps.

References:

David Groth and Toby Skandier, Network+ Study Guide(4th Edition), Sybex, AlamedaCA, 2005, p. 65.

QUESTION 7

Which frequency band is used in the IEEE 802.11b standard?

- A.1.5 GHz (Gigahertz)
- B.2.4 GHz (Gigahertz)
- C.5.0 GHz (Gigahertz)
- D.7.0 GHz (Gigahertz)

Answer: B

IEEE 802.11, IEEE 802.11b and IEEE 802.11g uses the 2.4 GHz frequency band.

Incorrect Answers:

A, D:NoIEEE wireless standard uses the 1.5 GHz or the 7.0 GHz frequency bands.

C:IEEE802.11a uses the 5.0 GHz frequency band, not 802.11b.

References:

David Groth and Toby Skandier,Network+ Study Guide(4th Edition), Sybex,AlamedaCA, 2005, pp. 249252.

QUESTION 8

Which standard covers the methods for performing authentication services for wireless access to a central LAN (Local Area Network)?

- A.802.5
- B.802.1x
- C.802.3
- D.802.4

Answer: B

802.1x is an authentication method for authenticating wireless users and requires them to authenticate at the WAP before

they are granted access to the network.

Incorrect Answers:

A:802.5 defines Token Ring.

C:802.3 defines Ethernet.

D:802.4 defines Token Bus.

References:

David Groth and Toby Skandier,Network+ Study Guide(4th Edition), Sybex,AlamedaCA, 2005, pp. 6365, 340.

QUESTION 9

Which of the following IEEE (Institute of Electrical and Electronics Engineers) standards represents Ethernet?

- A.802.0
- B.802.3
- C.802.5
- D.802.11

Answer: B

The IEEE 802.3 standard defines a network that uses a bus topology, baseband signaling, and a CSMA/CD network

access method. This standard was developed to match the Digital, Intel, and Xerox

N10-003

(DIX) Ethernet networking technology and is referred to as Ethernet.

Incorrect Answers:

A: There is not IEEE 802.0 standard.

C: IEEE 802.5 represents Token Ring, not Ethernet.

D: IEEE 802.11 represents Wireless LAN, not Ethernet.

References:

David Groth and Toby Skandier, Network+ Study Guide (4th Edition), Sybex, Alameda CA, 2005, pp. 6366.

QUESTION 10

Which of the following topologies does FDDI (Fiber Distributed Data Interface) require?

A. Star

B. Bus

C. Ring

D. Mesh

Answer: C

FDDI is a token passing network using fiberoptic

cable. It is similar to Token Ring but uses two rings that counterrotate

instead of one ring. If a failure occurs, the counterrotating rings can join together forming a ring around

the fault, thus isolating the fault and allowing communications to continue.

Reference:

David Groth, Network+ Study Guide (3rd Edition), Sybex, Alameda, 2002, pp. 330.

QUESTION 11

Which of the following media access methods is used in an IEEE (Institute and Electronics Engineers) 802.3 network?

A. Polling

B. Token passing

C. CSMA / CD (Carrier Sense Multiple Access / Collision Detection)

D. CSMA / CA (Carrier Sense Multiple Access / Collision Avoidance)

Answer: C

An IEEE 802.3 network is Ethernet which uses CSMA / CD (Carrier Sense Multiple Access / Collision Detection).

Incorrect Answers:

A: Polling is a media access control method that uses a central device called a controller that polls each device in turn and

asks if it has data to transmit.

B: Token passing occurs in Token Bus and Token Ring networks which are IEEE 802.4 and IEEE 802.5 networks respectively.

D: CSMA / CA (Carrier Sense Multiple Access / Collision Avoidance) occurs in Wireless LANs which are 802.11

networks.

Reference:

David Groth and Toby Skandier, Network+ Study Guide (4th Edition), Sybex, Alameda CA, 2005, p. 6366.

QUESTION 12

Which of the following access methods does Ethernet use?

- A. Token passing
- B. Full duplex
- C. CSMA / CA (Carrier Sense Multiple Access / Collision Avoidance)
- D. CSMA / CD (Carrier Sense Multiple Access / Collision Detection)

Answer: D

Ethernet uses CSMA / CD (Carrier Sense Multiple Access / Collision Detection).

Incorrect Answers:

A: Token passing occurs in Token Bus and Token Ring.

B: Full duplex describes a transmission characteristic in which data can be transmitted in both directions simultaneously.

This is possible in Ethernet, but is not an access method.

C: CSMA / CA (Carrier Sense Multiple Access / Collision Avoidance) occurs in Wireless networks.

Reference:

David Groth and Toby Skandier, Network+ Study Guide (4th Edition), Sybex, Alameda CA, 2005, p. 6366.

QUESTION 13

Which of the following are NOT terminated on a punch down block?

- A. STP (Shielded Twisted Pair) cable
- B. MMF (MultiMode Fiber) cable
- C. UTP (Unshielded Twisted Pair) cable
- D. Category 3 cable

Answer: B

Fiber optic cable is not terminated.

Incorrect Answers:

A, C: All twisted pair copper cable, be they shielded twisted pair or unshielded twisted, is terminated on a punch down block.

D: Category 3 cable is a twisted pair copper cable. All twisted pair copper cable is terminated on a punch down block.

References:

David Groth and Toby Skandier, Network+ Study Guide (4th Edition), Sybex, Alameda CA, 2005, pp. 2022, 271272.

QUESTION 14

Certkiller .com has recently installed a number of ceiling fans in its offices. No users are complaining of slow activity on the LAN and WAN. Nothing on the Category 5 UTP network has changed to cause this. What is the most likely cause of this problem?

- A. AMI (Alternate Mark Inversion)

N10-003

- B.EMI (Electromagnetic Interference)
- C.MIB (Management Information Base)
- D.FDM (Frequency Division Multiplexing)

Answer: B

UTP networks are susceptible to EMI which could be caused by the motors in the ceiling fans.

Incorrect Answers:

A:AMI is a line encoding technique for T1 connections. It uses bipolar pulses to represent logical values and does not affect UTP networks.

C:MIB is a database containing the information pertinent to network management. It allows for the management of network technologies such as Remote Access Routing Services, IP Helper, and SNMP.

D:FDM is used in Wireless networks. It is a multiplexing technique that sends different signals over multiple frequencies.

It does not affect UTP networks.

References:

David Groth and Toby Skandier, Network+ Study Guide(4th Edition), Sybex, Alameda CA, 2005, pp. 237-238, 241, 250.

http://en.wikipedia.org/wiki/Alternate_Mark_Inversion

<http://msdn.microsoft.com/library/default.asp?url=/library/enus/mib/mib/portal.asp>

QUESTION 15

Which of the following IEEE (Institute of Electrical and Electronic Engineers) standards requires copper cable?

- A. 10BASEFL
- B. 100BASEFX
- C. 100BASECX
- D. 10GBASELR

Answer: C

Only 100BASECX uses copper cable.

Incorrect Answers:

A, B, D: 10BASEFL, 100BASEFX, and 10GBASELR

all use fiber optic cable.

Reference:

David Groth and Toby Skandier, Network+ Study Guide(4th Edition), Sybex, Alameda CA, 2005, pp. 1731.

QUESTION 16

Which of the following Ethernet standards is fiber optic based?

- A. 1000BASETX

- B.10 GBASELR
- C.1000BASECX
- D.10BASET

Answer: B

Only 10 GBASE-LR is fiber optic based.

Incorrect Answers:

A, C, D:1000BASE-TX,1000BASE-CX, and 10BASE-T are all copper cable based.

Reference:

David Groth and Toby Skandier,Network+ Study Guide(4th Edition), Sybex,AlamedaCA, 2005, pp. 1731.

QUESTION 17

Which of the following IEEE (Institute of Electrical and Electronics Engineers) standards uses a 1300 nm (nanometer) beam?

- A.1000BASE-LX and 10 GBASE-LR
- B.1000BASE-CX and 1000BASE-T
- C.1000BASE-SX and 10 GBASE-SR
- D.10 GBASE-ER and 10 GBASE-SR

Answer: A

1000BASE-LX and 10 GBASE-LR used long wavelength beams of 1300 nanometers (nm).

Incorrect Answers:

B:1000BASE-CX and 1000BASE-T uses twisted pair copper wires. However, beams are used in optical cable.

C:1000BASE-SX and 10 GBASE-SR uses short wavelength beams of 850 nanometers (nm).

D:10 GBASE-ER uses 1550 nanometers (nm) beams while 10 GBASE-SR uses 850 nm beams.

References:

David Groth and Toby Skandier,Network+ Study Guide(4th Edition), Sybex,AlamedaCA, 2005, pp. 23-24.

QUESTION 18

Which of the following media types is the MOST prone to EMI (electromagnetic interference)?

- A.Category 5e UTP (Unshielded Twisted Pair)
- B.RG-58 (Radio Grade) coaxial cable
- C.SMF (Single Mode Fiber) optic cable
- D.MMF (MultiMode Fiber) optic cable

Answer: A

UTP (Unshielded Twisted Pair) cable is susceptible to EMI (electromagnetic interference).

Incorrect Answers:

B:RG-58 coaxial cable is also susceptible to EMI, but not to the same extent as UTP.

C, D:Both SMF and MMF optic cable are immune to EMI.

References:

David Groth and Toby Skandier,Network+ Study Guide(4th Edition), Sybex,AlamedaCA, 2005, pp. 1920, 2527.

QUESTION 19

What is the maximum length of a cable used for 1000BASESX?

N10-003

- A.100 meters(328.08 feet)
- B.250 meters(820.21.feet)
- C.550 meters(1,804.46 feet)
- D.3000 meters(9,842.52 feet)

Answer: C

1000BASE-SX uses multimode fiber optic cable that has a maximum transmission distance of 550 meters.

References:

David Groth and Toby Skandier,Network+ Study Guide(4th Edition), Sybex,AlamedaCA, 2005, pp. 30-31.

QUESTION 20

What is the maximum length of a cable used for 100BASEFX?

- A.100 meters(328.08 feet)
- B.250 meters(820.21.feet)
- C.550 meters(1,804.46 feet)
- D.2000 meters (6,561.68 feet)

Answer: D

100BASEFX

uses multimode fiber optic cable that has a maximum transmission distance of 2000 meters.

References:

David Groth and Toby Skandier,Network+ Study Guide(4th Edition), Sybex,AlamedaCA, 2005, pp. 30-31.

QUESTION 21

What is the maximum length of a cable used for 100BASE-TX?

- A.100 meters(328.08 feet)
- B.250 meters(820.21.feet)
- C.550 meters(1,804.46 feet)
- D.2000 meters (6,561.68 feet)

Answer: A

100BASE-TX uses multimode fiber optic cable that has a maximum transmission distance of 100 meters.

References:

David Groth and Toby Skandier,Network+ Study Guide(4th Edition), Sybex,AlamedaCA, 2005, pp. 3031.

QUESTION 22

Which type of connector would a cable have if it were supplied with a splitter and a cable modem for Internet access?

- A.F-Type
- B.RJ-45 (Registered Jack)
- C.RJ-11 (Registered Jack)
- D.IEEE 1394 (Institute of Electrical and Electronics Engineers)

Answer: A

Cable modems have two connections: one to the computer, which can be Ethernet using RJ-45 or USB; and the other feeds into the cable of the cable supplier, which uses an F-Type coaxial connector. The F-Type connector can

be

attached to a splitter to send signals to a cable TV.

Incorrect Answers:

B: The RJ-45 connector connects the cable modem to the computer, not to the splitter.

C: The cable modem does not have an RJ-11 connector. The RJ-11 connector is used for telephone cables attached to

analog modems.

D: IEEE 1394 is FireWire. Cable modems do not have FireWire connectors.

References:

David Groth and Toby Skandier, Network+ Study Guide (4th Edition), Sybex, Alameda CA, 2005, pp. 290-292.

QUESTION 23

Which of the following connectors are SFF (Small Form Factor) fiber connectors?

A. MT-RJ (Mechanical Transfer-Registered Jack) and LC (Local Connector)

B. ST (Straight Tip) and SC (Standard Connector)

C. RJ-45 (Registered Jack) and RJ-11 (Registered Jack)

D. Series-A and Series-B

Answer: A

Both MT-RJ and LC are small form factor fiber connectors.

Incorrect Answers:

C: RJ-45 and RJ-11 are connectors for twisted pair, copper cables, and are not fiber connectors.

B: ST and SC are fiber connectors, but are not small form factor.

D: Series-A and Series-B are USB connectors, not fiber connectors.

References:

David Groth and Toby Skandier, Network+ Study Guide (4th Edition), Sybex, Alameda CA, 2005, pp. 2629.

QUESTION 24

Which of the following connectors does a 10BASE-F network require?

A. MT-RJ (Mechanical Transfer-Registered Jack)

B. RJ-45 (Registered Jack)

C. Series-A

D. ST (Straight Tip)

Answer: D

In 10BASE-F, the F is for fiber. Thus, 10BASE-F requires a fiber-optic connection, of which MT-RJ and ST are examples. However, 10BASE-F is an older fiber-optic Ethernet standard and would use the older ST or SC connectors.

Incorrect Answers:

A: MT-RJ (Mechanical Transfer-Registered Jack) is a small form factor fiber-optic connector and is approximately

one-third the size of the SC and ST connectors. These connectors are found on the newer fiber-optic Ethernet standards.

B: The RJ-45 (Registered Jack) connector is used on twisted pair cables, not fiber-optic cables. The 10BASE-F requires

a fiber-optic cable.

C:The Series-A connector is a USB connector.

Reference:

David Groth and Toby Skandier,Network+ Study Guide(4th Edition), Sybex,AlamedaCA, 2005, pp. 2229.

QUESTION 25

Which of the following is NOT a fiber based connector?

A.ST (Straight Tip)

B.MT-RJ (Mechanical Transfer-Registered Jack)

C.IEEE 1394 (Institute of Electrical and Electronics Engineers)

D.SC (Standard Connector)

Answer: C

IEEE 1394 is FireWire. FireWire cables use either a 6 pin connector or a 4 pin connector. FireWire cables with the

6-pin connector have three pairs of copper wire, two pairs for carrying data and one pair for powering devices.

FireWire cables with the 4-pin connector have only two pairs of copper wire for carrying data.

Incorrect Answers:

A, D:ST (Straight Tip) and SC (Standard Connector) are the two most popular fiber-optic connectors.

B:MT-RJ (Mechanical Transfer-Registered Jack) is a small form factor fiber-optic connector and is approximately

one-third the size of the SC and ST connectors.

Reference:

David Groth and Toby Skandier,Network+ Study Guide(4th Edition), Sybex,AlamedaCA, 2005, pp. 24-31.

QUESTION 26

The system administrator needs to connect a server to a 100BASE-T switch. Which cable is required?

A.Category 3 cable

B.Category 5 cable

C.MMF (MultiMode Fiber) optic cable

D.SMF (Single Mode Fiber) optic cable

Answer: B

100BASE-T uses twisted pair cable as indicated by the T in 100BASE-T.100Base-T has a transmissions speed of up

to 100 Mbps. The minimum twisted-pair,coppercablethat can support these speeds are Category 5 cable.

Incorrect Answers:

A:Category 3 cable is rated at only 10 Mbps and is used in 10BASE-T,not 100BASE-T

C, D:1000BASE-T uses twisted pair cable as indicated by the T in 1000BASE-T,not optical cable.

References:

David Groth and Toby Skandier,Network+ Study Guide(4th Edition), Sybex,AlamedaCA, 2005, pp. 20-21,23, 144.

QUESTION 27

You need to connect the 100BASETX

NICs on two workstations with directly. Which cable could you use?

N10-003

- A. Category 5 crossover cable
- B. Coaxial cable
- C. Category 3 straight cable
- D. Category 5 straight cable

Answer: A

Both workstations' NIC will be physically and electronically the same as a medium dependent interface (MDI), therefore, you need a crossover cable to connect the two together. 100BASE-TX uses twisted pair cable as indicated

by the T in 100BASE-TX. 100Base-T has a transmission speed of up to 100 Mbps. The minimum twisted-pair, copper cable that can support these speeds are Category 5 cable.

Incorrect Answers:

B: 100BASE-TX uses twisted pair cable as indicated by the T in 100BASE-TX, not coaxial cable.

C: Straight cable can connect a workstation on a 100BASE-TX network to hub, router, or switch. However, a crossover cable is required to connect two client workstations directly. Furthermore, Category 3 cable is rated at only

10 Mbps and is used in 10BASE-T.

D: Straight cable can connect a workstation on a 100BASE-TX network to hub, router, or switch, which would have

medium dependent interface-crossover (MDI-X) port. However, a crossover cable is required to connect two client

workstations directly as the two workstations will have similar medium dependent interfaces (MDIs).

References:

David Groth and Toby Skandier, Network+ Study Guide (4th Edition), Sybex, Alameda CA, 2005, pp. 20-21, 23, 144, 290-292, 436-437.

QUESTION 28

What is the minimum cable type required for 100BASE-TX?

- A. 50 ohm coaxial cable
- B. Category 3 UTP (Unshielded Twisted Pair)
- C. Category 6 UTP (Unshielded Twisted Pair)
- D. Category 5 UTP (Unshielded Twisted Pair)

Answer: D

100BASE-TX requires a UTP cable that can support transmission speeds of up to 100 Mbps. The minimum UTP cable

that supports transmission speeds of up to 100 Mbps is Category 5 cable.

Incorrect Answers:

A: 50 ohm coaxial cable is called RG-58. This is thinnet cable that is used for 10BASE-2.

B: Category 3 cable has a maximum transmission speed to 10 Mbps.

C: Category 6 cable supports transmission speeds of up to 1000 Mbps and can be used for 100BASE-TX. However,

Category 5 cable which has a maximum transmission speed of 100 Mbps can also be used.

Reference:

David Groth and Toby Skandier, Network+ Study Guide (4th Edition), Sybex, Alameda CA, 2005, pp. 20-21.

QUESTION 29

Which of the following media types does 100BASE-FX require?

- A.RG-8(Radio Grade) coaxial cable
- B.RG-58 (Radio Grade) coaxial cable
- C.MMF (Multimode Fiber) optic cable
- D.UTP (Unshielded Twisted Pair) cable

Answer: C

Explanation:

In 100BASE-FX,F stands for fiber. Thus, 100BASE-FX requires fiber optic cable.

Incorrect Answers:

- A:RG-8 coaxial cable is called Thicknet and isrequiredfor 10BASE-5, not 100BASE-FX.
- B:RG-58 coaxial cable is called Thinnet and is required for 10BASE-2,not 100BASE-FX.
- D:UTP is required for 10BASE-T,100BASE-T,100BASE-TX,etc, not 100BASE-FX.

Reference:

David Groth and Toby Skandier,Network+ Study Guide(4th Edition), Sybex,AlamedaCA, 2005, pp. 1731.

QUESTION 30

If a destination address is not in a bridge forwarding table, what will the bridge do?

- A.Forwarding the packets to a designated port and the one that originated the request
- B.Forward the packets to all ports except the one that originated the request
- C.Forward the packets to the default gateway
- D.Forward the packet to all ports

Answer: D

Bridges read each frame as it passes through it. It then puts the source hardware address in a forwarding table and

keeps track of which port the frame was received on, to determine the location of the sending device. Once a forwarding table is built, the bridge will only forward frames to the segment where the destination hardware address is

located. If the destination device is on the same segment as the frame, the bridge will block the frame from going to any

other segments. If the destination address is on a different segment, the frame will only be transmitted to that segment.

However, if the destination address is not on bridge's forwarding table, it broadcasts the packet through all ports.

References:

Todd Lammle,CCNA: Cisco Certified Network Associate Study Guide(4th Edition), Sybex,AlamedaCA, 2004, pp. 20-21.

QUESTION 31

Which of the following options transmit data over a modem? (Select three)

- A.POTS/PSTN (Plain Old Telephone System/Public Switched Telephone Network)

- B.xDSL (Digital Subscriber Line)
- C.cable
- D.T1 (T-Carrier Level 1)

Answer: A, B, C

T1 is a dedicated point-to-point

link while POTS/PTSN, xDSL and cable all require a modem to modulate the digital data onto an analog carrier for transmission over an analog line and then demodulate from the analog carrier to a digital signal again at the receiving end.

References:

David Groth and Toby Skandier, Network+ Study Guide (4th Edition), Sybex, Alameda CA, 2005, pp. 34-35, 286-294.

QUESTION 32

You have purchased a cable modem and a straight-through Category 5e patch cable from a local electronics store. You connect the cable modem to your computer via a hub which is already connected to your computer. However, your computer is not able to receive a DHCP address from the cable modem network DHCP server. What is the most likely cause of this problem?

- A. The cable modem must be directly connected to a computer.
- B. The cable modem requires a crossover cable to connect to the hub.
- C. The cable modem requires a RG-6 coaxial cable to connect to a hub.
- D. The cable modem must use a Category 3 UTP cable to connect to a hub.

Answer: B

The cable modem's Ethernet connection is physically and electronically the same as a medium dependent interface-crossover (MDI-X) port on the hub, therefore, you need a crossover cable to connect the cable modem to the hub, and not a straight-through cable.

Incorrect Answers:

A: We can connect a cable modem to a computer via a hub. However, the cable modem's Ethernet connection is physically and electronically the same as a medium dependent interface-crossover (MDI-X) port on the hub, therefore, you need a crossover cable to connect the two.

C: Cable modems are either Ethernet based, which would require twisted pair cable, or USB to connect to the computer. This can be either directly, or via a hub or switch. The cable receives its signals via an RG-6 cable that connects to the wall socket, which feeds into the cable from the cable provider.

D: A Category 5e cable is backward compatible with a Category 3 cable. Therefore, changing to a Category 3 cable will not resolve the problem. The problem here is that the ports on both the cable modem and the hub are physically and electronically the same as a medium dependent interface-crossover (MDI-X) port on the hub, therefore, we need a crossover cable to connect the two.

References:

N10-003

David Groth and Toby Skandier, Network+ Study Guide (4th Edition), Sybex, Alameda CA, 2005, pp. 290-292, 436-437.

QUESTION 33

Which of the following are required to connect an 802.3 network to an 802.11 network?

- A. CSU / DSU (Channel Service Unit / Data Service Unit)
- B. WAP (Wireless Access Point)
- C. ISDN (Integrated Services Digital Network) adapter
- D. PVC (Permanent Virtual Circuit)

Answer: B

802.3 is an Ethernet LAN while 802.11 is the Wireless version of Ethernet. A WAP is used to connect a Wireless network to a LAN.

Incorrect Answers:

A: CSU / DSU is a device that connects a digital carrier line, such as the T-series or the DDS line to your network.

C: An ISDN adapter is a device that connects your network to the Internet.

D: PVC is used in Frame Relay to ensure that all data that enters a Frame Relay cloud at one side comes out at the other over a similar connection.

Reference:

David Groth and Toby Skandier, Network+ Study Guide (4th Edition), Sybex, Alameda CA, 2005, p. 63-69, 293.

QUESTION 34

A Certkiller employee requires remote access to the company network. The employee has access to the PSTN (Public Switched Telephone Network) which supports standard analog signaling. Which device will allow the employee to connect to the company network via remote access?

- A. Gateway
- B. Router
- C. ISDN (Integrated Services Digital Network)
- D. Modem

Answer: D

A modem can connect two computers over an analog telephone line.

Incorrect Answers:

A: A Gateway is a combination of software and a hardware device that can interconnect two dissimilar networks.

B: A Router is a network device that can interconnect two or more network segments.

C: ISDN is similar to a modem but does not accept analog signals and thus cannot accept dial-up signals which are analog.

Reference:

David Groth and Toby Skandier, Network+ Study Guide (4th Edition), Sybex, Alameda CA, 2005, pp. 33-35, 284.

QUESTION 35

Which of the following can be used to connect a LAN (Local Area Network) to mainframe?

- A.bridge
- B.gateway
- C.transceiver
- D.firewall

Answer: B

A LAN and a mainframe are two dissimilar networks. A gateway is used to connect two dissimilar networks.

Incorrect Answers:

A:A bridge connects two similar network segments and keeps traffic separated on both sides of the bridge. It does not

connect two dissimilar networks.

C:A transceiver allows a networking device to connect to a different type of media than it was designed for. It is not

used to connect networks.

D:A firewall protects the LAN from attackers on the Internet. It is not used to connect networks.

References:

David Groth and Toby Skandier,Network+ Study Guide(4th Edition), Sybex,AlamedaCA, 2005, pp. 33, 36-37.

QUESTION 36

You work as the network engineer at Certkiller .com. You notice that network traffic on Certkiller .com's its TCP/IP (Transmission Control Protocol/Internet Protocol) network has increased steadily over the last few months and is beginning to affect performance on. You want to reduce the impact of network traffic without dividing the LAN (Local Area Network) into separate subnets. Which networking device should you install?

- A.Bridge
- B.Repeater
- C.Router
- D.Gateway

Answer: C

Routers make decisions on how to best network data to its destination based on network performance data that it gathers from the network. This will help alleviate traffic on the LAN.

Incorrect Answers:

A:A bridge connects two similar network subnets and keeps traffic separated on both sides of the bridge.

However, this will result in subnetting.

B:A repeater amplifies the signals and is used to extend the maximum length of a network segment. It does not alleviate traffic.

D:A gateway is used to connect two dissimilar networks. It does not alleviate traffic on the internal LAN.

References:

David Groth and Toby Skandier,Network+ Study Guide(4th Edition), Sybex,AlamedaCA, 2005, pp. 33, 36-37.

QUESTION 37

On which of the following devices can NAT (Network Address Translation) be implemented?

- A.Hub
- B.Bridge
- C.Switch
- D.Firewall

Answer: D

NAT maps multiple private IP addresses to a single public IP addresses, allowing users to access a public network such

as the Internet, and can be implemented on a router or firewall.

Incorrect Answers:

A, B, C:Hubs, bridges and switches connect computers together to form a LAN (local area network). They do not

connect computers to the Internet, neither are they connected to the Internet. NAT maps multiple private IP addresses

to a single public IP addresses, allowing users to access the public network, i.e., the Internet. Therefore, the device that

provides NAT must be connected to the Internet.

References:

David Groth and Toby Skandier,Network+ Study Guide(4th Edition), Sybex,AlamedaCA, 2005, pp. 35-37, 111-112.

QUESTION 38

Which of the following Wireless standards supports a maximum speed of 54 Mbps?

- A.802.11
- B.802.15
- C.802.11b
- D.802.11g

Answer: D

IEEE 802.11a and IEEE 802.11g has transmission speeds of up to 54 Mbps.

Incorrect Answers:

A:IEEE 802.11, the original standard for wireless networks operates at a maximum speed of 2 Mbps.

B:802.15isalso known a Bluetooth and has a maximum transmission speed of 420 Kbps in symmetric mode.

C:IEEE 802.11b operates at a maximum speed of 11 Mbps.

Reference:

David Groth and Toby Skandier,Network+ Study Guide(4th Edition), Sybex,AlamedaCA, 2005, p. 66.

QUESTION 39

Which of the following frequency bands does IEEE 802.11b use?

- A.1.5 GHz
- B.2.4 GHz
- C.5.0 GHz
- D.7.0 GHz

Answer: B

802.11b uses the unlicensed 2.4 GHz frequency band.

Incorrect Answers:

A, D:None of the IEEE 802.11 based Wireless standards operates at the 1.5 GHz or 7.0 GHz frequency bands.

C:802.11a and 802.11g uses the 5.0 GHz frequency band.

Reference:

David Groth and Toby Skandier,Network+ Study Guide(4th Edition), Sybex,AlamedaCA, 2005, p. 66.

QUESTION 40

What is the maximum transmission speed supported by IEEE 802.11b?

A.1 Mbps

B.2 Mbps

C.11 Mbps

D.54 Mbps

Answer: C

IEEE 802.11b has a transmission speed of up to 11 Mbps.

Incorrect Answers:

B:IEEE 802.11, the original standard for wireless networks operates at a maximum speed of 2 Mbps.

D:IEEE 802.11g operates at a maximum speed of 54 Mbps.

Reference:

David Groth and Toby Skandier,Network+ Study Guide(4th Edition), Sybex,AlamedaCA, 2005, p. 66.

QUESTION 41

How can the range of an 802.11b wireless access point be increased?

A.Lower the output power

B.Install an external antenna

C.Remove any external antennas and use the internal one

D.Change the transmitting frequency to the 5 GHz (Gigahertz) range

Answer: B

External antennas have a range of about 1500ft while internal antennas have a range of 300ft. Thus, installing an external

antenna will greatly increase the range of the WAP.

Incorrect Answers:

A:The output power does not affect the range of a WAP.

C:External antennas have a range of about 1500ft while internal antennas have a range of 300ft. Thus, replacing the

external antennas with internal antennas will greatly reduce the range of the WAP.

D:802.11b wireless networks operate at frequency of 2.4 GHz. This cannot be changed. Furthermore, higher frequencies have a shorter range because they attenuate sooner.

References:

David Groth and Toby Skandier,Network+ Study Guide(4th Edition), Sybex,AlamedaCA, 2005, pp. 250-252,255.

QUESTION 42

Which of the following antenna types is omnidirectional?

- A. Vertical
- B. Dipole
- C. Yagi
- D. Parabolic

Answer: A

A vertical antenna, such as a car radio antenna, is an example of an omnidirectional antenna.

Incorrect Answers:

B: Dipole is one of the ratings that are used to describe the characteristics of an antenna, regardless of whether they are directional or omnidirectional antennas.

C: The Yagi antenna is a directional antenna used for point-to-point bridging of WAPs.

D: There is no parabolic antenna.

References:

David Groth and Toby Skandier, Network+ Study Guide (4th Edition), Sybex, Alameda CA, 2005, pp. 246-248.

QUESTION 43

Which of the following environments is BEST suited for using an omnidirectional antenna?

- A. Closed office areas with walls
- B. Open office areas with cubicles
- C. Hallways
- D. Outdoors

Answer: D

Omnidirectional antennas transmit in all directions and have their greatest range in open spaces, such as outdoors, although they could be used indoors as well.

References:

David Groth and Toby Skandier, Network+ Study Guide (4th Edition), Sybex, Alameda CA, 2005, pp. 246-248, 473.

QUESTION 44

You work as a network administrator at Certkiller .com. You are troubleshooting a wireless LAN that is experiencing interference. A scan of the wireless network reports that there are two other WAPs from different companies within range of the LAN. The two foreign WAPs have different SSIDs than the LAN WAP, but are on the same channel. Also, the WEP appears to be the same on all WAPs. What should you do to reduce this wireless interference?

- A. Change the LAN WAP to the same SSID as the two foreign WAPs.
- B. Change the WEP settings on the LAN WAP to be different than that of the two foreign WAPs.
- C. Change the LAN WAP channel to a different channel than the two foreign WAPs.
- D. Change the LAN WAP settings to be different than that of the two foreign WAPs.

Answer: C

N10-003

The interference is a result of the proximity of the two foreign wireless LANs. Because they are using the same channel, the three wireless LANs are interfering with each other's signals. We can reduce this interference by changing the channel that our WAP is using.

Incorrect Answers:

A: The SSID (Security Set Identifier) identifies a particular wireless network. All WAPs on the same wireless network must have the same SSID. However, the two foreign WAPs are not part of the Certkiller network and should not be configured with the same SSID.

B: It appears that the default settings are enabled on the three WAPs. Therefore the WEP (Wired Equivalent Privacy)

appears to be the same. WEP is a security feature that requires that both the WAP and workstation have the same 64-bit, 128-bit, 152-bit, or 256-bit encryption key in order to communicate. Changing the WEP will ensure that users

from the foreign companies will not be able to communicate with our WAP. However, this will not reduce the interference.

D: This option is a bit vague. The WAP settings include the channel, the SSID, the WEP key, etc. If we change all of

these we are sure to reduce interference, because we would also be changing the channel. However, we could just change the channel.

References:

David Groth and Toby Skandier, *Network+ Study Guide* (4th Edition), Sybex, Alameda CA, 2005, pp. 253-255, 259.

QUESTION 45

Which one of the following will affect the range of an 802.11b WAP (Wireless Access Point)?

- A. 5 GHz interference
- B. High number of wireless users
- C. 900 MHz interference
- D. A long length of antenna extension cable

Answer: D

The positioning of the WAP's antenna will affect its range, however, the extension cable could also lead to signal loss.

Incorrect Answers:

A, C: 802.11b uses the 2.4 GHz frequency range and is therefore not susceptible to interference in the 900 MHz or 5 GHz frequency ranges.

D: The number of users connected via a WAP will influence the transmission speed rather than the range.

Reference:

David Groth and Toby Skandier, *Network+ Study Guide* (4th Edition), Sybex, Alameda CA, 2005, pp. 252, 255.

QUESTION 46

Which 3 bytes of MAC address F2A123BCD341 designates the unique station identifier?

- A.F2-A1-23
- B.A1-23-BC
- C.23-BC-D3
- D.BC-D3-41

Answer: D

A MAC Address consists of two parts: an Organizationally Unique Identifier (OUI) which is administered by the IEEE

and uniquely identifies

sets of digits represent the OUI while the last three digits represent the device ID.

References:

David Groth and Toby Skandier, Network+ Study Guide (4th Edition), Sybex, Alameda CA, 2005, p. 120.

QUESTION 47

Which 3 bytes of MAC address F2-A1-23-BC-D3-41 designates the OUI (Organizationally Unique Identifier)?

- A.F2-A1-23
- B.A1-23-BC
- C.23-BC-D3
- D.BC-D3-41

Answer: A

A MAC Address consists of two parts: an Organizationally Unique Identifier (OUI) which is administered by the IEEE

and uniquely identifies

sets of digits represent the OUI while the last three digits represent the device ID.

References:

David Groth and Toby Skandier, Network+ Study Guide (4th Edition), Sybex, Alameda CA, 2005, p. 120.

QUESTION 48

At which layers of the OSI (Open Systems Interconnect) model does a packet filtering firewall operate?

- A. Network and Data Link Layers.
- B. Network and Transport Layers.
- C. Transport and Session Layers.
- D. Physical and Data Link Layers.

Answer: B

The Network Layer of the OSI model is responsible for end-to-end delivery of data packets. This includes routing and

can include packet filtering. The Transport Layer of the OSI model is responsible for several functions, including the

choice of protocols, error recovery and flow control, reordering of the incoming data stream. Through flow control,

N10-003

packet filtering can be implemented.

Incorrect Answers:

A: The Network Layer of the OSI model is responsible for end-to-end delivery of data packets. This includes routing

and can include packet filtering. However, the Data Link Layer of the OSI model is the link between the computer's

networking hardware and networking software. This layer is responsible for getting data across one particular link or

medium. This does not involve packet management or filtering.

C: The Transport Layer of the OSI model is responsible for several functions, including the choice of protocols, error

recovery and flow control, reordering of the incoming data stream. Through flow control, packet filtering can be implemented. However, the Session Layer of the OSI model is responsible for establishing, maintaining, and ending

sessions. These are not functions required for packet filtering.

D: The Physical Layer of the OSI model is responsible for the actual, physical connection to the network. This function

does not involve packet management or filtering. Also, the Data Link Layer of the OSI model is the link between the

computer's networking hardware and networking software. This layer is responsible for getting data across one particular

link or medium. This does not involve packet management or filtering.

References:

David Groth and Toby Skandier, Network+ Study Guide (4th Edition), Sybex, Alameda CA, 2005, pp. 5181.

QUESTION 49

At which of the following OSI layers are digital data converted into electronic signals to be put on a wire?

A. The Physical Layer

B. The Transport Layer

C. The Data Link Layer

D. The Presentation Layer

Answer: A

The Physical Layer of the OSI is concerned with the physical elements of the network. This includes the transmission

medium and physical topology. One of the functions of the Physical Layer is signal encoding, which is the translation of

data into electronic signals that can be transmitted on a transmission medium.

Incorrect Answers:

B: The Transport Layer of the OSI is concerned about the structure of messages and the validity of transmissions. It is

not responsible for signal encoding.

C: The Data Link Layer of the OSI is concerned with getting data across a particular link or medium and defines delivery across an individual link. It is not responsible for signal encoding.

D: The Presentation Layer of the OSI is responsible to converting transmitted data into a format that can be used by

applications. It is not responsible for signal encoding.

References:

David Groth and Toby Skandier, Network+ Study Guide (4th Edition), Sybex, Alameda CA, 2005, pp. 4681.

QUESTION 50

At which of the following OSI layers does a router function?

- A. The Physical Layer
- B. The Data Link Layer
- C. The Network Layer
- D. The Application Layer

Answer: C

The Network Layer of the OSI ensures that the data arrives at the correct destination. As such, it is concerned with

network addressing and routing. A router is responsible for routing and functions at the Network Layer.

Incorrect Answers:

A: The Physical Layer of the OSI is concerned with the physical elements of the network. This includes the transmission

medium and physical topology. However, a router is used to route data on a routed network. This is a function of the

Network Layer.

B: The Data Link Layer of the OSI is concerned with getting data across a particular link or medium and defines delivery

across an individual link. However, a router is used to route data on a routed network, rather than on a physical link.

D: The Application Layer of the OSI is the interface between the network and the application.

References:

David Groth and Toby Skandier, Network+ Study Guide (4th Edition), Sybex, Alameda CA, 2005, pp. 46-81.

QUESTION 51

Which of the following OSI (Open Systems Interconnect) layers is responsible for formatting and code conversations?

- A. The Transport Layer
- B. The Data Link Layer
- C. The Application Layer
- D. The Presentation Layer

Answer: D

The Presentation Layer of the OSI model converts the data from the lower layers into a format that the upper layer

processes require. In addition, the Presentation Layer also provides encryption, data compression, and character set

translation, which is also called code conversion.

Incorrect Answers:

A: The Transport Layer of the OSI model defines several functions, including the choice of protocols, error recovery

and flow control.

B: The Data Link Layer of the OSI model is the channel between the computer's networking hardware and networking software. This layer is concerned with getting data across one particular link or medium and defines delivery across an individual link.

C: The Application Layer of the OSI model layer defines several standard network services, such as the Simple Mail Transfer Protocol (SMTP), as well as the interface between the network and the application. Applications use these services to access the network.

References:

David Groth and Toby Skandier, Network+ Study Guide (4th Edition), Sybex, Alameda CA, 2005, pp. 59, 77, 81.

QUESTION 52

Which of the following networking devices operate at the upper three layers of the OSI (Open Systems Interconnect) and connects networks with different architectures?

- A. Router
- B. Firewall
- C. Modem
- D. Gateway

Answer: D

A gateway is used to connect two dissimilar networks. It operates at all the layers of the OSI.

Incorrect Answers:

A: A router operates at the Network Layer of the OSI. The Network Layer is in the middle layers, not the upper layers, of the OSI.

B: A firewall protects the LAN from attackers on the Internet. It is not used to connect networks.

C: A modem provides access to the Internet. It operates at the lower layers of the OSI.

References:

David Groth and Toby Skandier, Network+ Study Guide (4th Edition), Sybex, Alameda CA, 2005, pp. 33, 36-37.

QUESTION 53

Which of the following are classified as Layer 2 devices?

- A. Hubs, switches and routers
- B. Hubs, switches and bridges
- C. Switches, bridges, and NICs (Network Interface Cards)
- D. Switches, bridges and routers

Answer: B

Hubs, switches and bridges all operate at the Data Link Layer of the OSI and are thus Layer 2 devices.

A, D: Hubs, switches and bridges all operate at the Data Link Layer of the OSI and are thus Layer 2 devices. However, routers operate at the Network Layer of the OSI and are thus Layer 3 devices.

C: Switches and bridges operate at the Data Link Layer of the OSI and are thus Layer 2 devices. However, NICs operate at the Physical Layer of the OSI and are thus Layer 1 devices.

References:

David Groth and Toby Skandier, Network+ Study Guide (4th Edition), Sybex, Alameda CA, 2005, pp. 54-55, 66-69.

QUESTION 54

You are the network administrator at Certkiller .com. You want to configure a computer to run SLIP as a dial-up protocol. Which protocol should you install?

- A. TCP/IP
- B. IPX/SPX
- C. NetBEUI
- D. Appleshare IP

Answer: A

SLIP is a part of the TCP/IP protocol suite.

QUESTION 55

With regard to TCP and UDP, which of the following statements are true?

- A. TCP is connection-oriented, UDP is reliable.
- B. TCP is connectionless, UDP is unreliable.
- C. TCP is connection-oriented, UDP is unreliable.
- D. TCP is connectionless, UDP is reliable.

Answer: C

TCP is connection-oriented, while UDP is connectionless. This means that TCP provides reliable, verifiable data exchange between hosts on a network, while UDP does not provide reliability.

References:

David Groth and Toby Skandier, Network+ Study Guide (4th Edition), Sybex, Alameda CA, 2005, pp. 80, 107-109, 119

QUESTION 56

An ICS network has been setup as follows:

ICS (Internet Connection Sharing) Host:

Windows 2000 Professional

A 3com NIC (Network Interface Card)

An Intel Etherlink NIC (Network Interface Card)

File and print sharing enabled

TCP / IP (Transmission Control Protocol / Internet Protocol) installed

ICS (Internet Connection sharing) Client Certkiller 1:

Windows 98 2nd Edition

A 3com NIC (Network Interface Card)

File and print sharing enabled

IPX / SPX (Internetwork Packet Exchange / Sequence Packet Exchange) installed

ICS (Internet Connection Sharing) Client Certkiller 2:

Windows 98 2nd Edition

N10-003

A 3com NIC (Network Interface Card)

An Intel Etherlink NIC (Network Interface Card)

File and print sharing enabled

TCP / IP (Transmission Control Protocol / Internet Protocol) installed.

The user of Certkiller 1 complains that she cannot connect to the Internet. What is the cause of this problem?

A.TCP / IP (Transmission Control Protocol / Internet Protocol)hasnot been installed on Certkiller 1.

B.Windows 2000 Professional does not support ICS (Internet Connection Sharing).

C. Certkiller 1 and Certkiller 2 both need two NICs (Network Interface Card) installed.

D.File and print sharing should be installed on the ICS Host only.

Answer: A

ICS is only supported on TCP/IP networks, not on IPX/SPX networks. Therefore, TCP/IP must be installed on Certkiller 1.

Incorrect Answers:

B:ICS is supported inWindows 98 (Second Edition), Windows 2000 Professional, Windows 2000 Server and Windows XP. It is not supported in Windows Sever 2003.

C:The requirements for ICS are: an operating system that supports ICS, and a network connection to the ICS host. Thus,

one NIC will be sufficient.

D:File and print sharing does not impact on ICS.

References:

Lisa Donald and James Chellis,MCSA/MCSE Windows XP Professional(3rd Edition), Sybex,AlamedaCA, 2005, pp. 512-517.

QUESTION 57

Which of the following protocol uses domain name resolution to find addresses?

A.TCP / IP (Transmission Control Protocol / Internet Protocol)

B.IPX / SPX (Internetwork Packet Exchange / Sequence Packet Exchange)

C.NetBEUI (Network Basic Input / Output Extended User Interface)

D.AppleTalk

Answer: A

TCP/IP uses DNS for name resolution.

Incorrect Answers:

B:IPX/SPX does not employ a name resolution system.

C:NetBEUI has no structure to its addressing format, making name resolution impossible.

D:AppleTalk uses the Name Binding Protocol (NBP) to resolve a computer name to its network address.

Reference:

David Groth and Toby Skandier,Network+ Study Guide(4th Edition), Sybex,AlamedaCA, 2005, pp. 78-80,90, 143.

QUESTION 58

Which of the following IP addresses are NOT valid?

A.192.168.0.1

B.172.192.4.256

N10-003

C.156.144.226.123
D.10.24.12.0

Answer: B

IP addresses consist of four sets of 8 bit numbers called octets. 8 bit numbers have a maximum decimal value of 255.

The address 172.192.4.256 has the decimal value 256 in the last octet. This is not valid.

Note:the IP address 10.24.12.0 is not a valid IP address for a host but is a valid network address.

References:

David Groth and Toby Skandier,Network+ Study Guide(4th Edition), Sybex,AlamedaCA, 2005, pp. 125-126.

QUESTION 59

Which one of the following is a class A IP (Internet Protocol) address?

- A.172.168.12.4
- B.18.12.4.1
- C.169.254.254.254
- D.255.255.255.0

Answer: B

Class A IP addresses use the first 8 bits for network identification and the last 24 bits for host identification. The result is

an IP address range from 0.0.0.0 through 127.255.255.255 and a default subnet mask of 255.0.0.0. However, 127.0.0.0 through 127.255.255.255 is reserved for diagnostics.

Incorrect Answers:

A:172.168.12.4 is a class B IP address. Class B IP addresses use the first 16 bits for network identification and the last

16 bits for host identification. The result is an IP address range from 128.0.0.0 through 191.255.255.255 and a default

subnet mask of 255.255.0.0. However, 169.0.0.0 through 169.255.255.255 is reserved.

B:169.254.254.254 is a self-assigned

address that is reserved for use by DHCP clients that fail to acquire a DHCP lease from a DHCP server. It is from the class B range of IP addresses.

C:255.255.255.0 is a subnet mask. This is the default subnet mask for a class C IP address.

References:

David Groth and Toby Skandier,Network+ Study Guide(4th Edition), Sybex,AlamedaCA, 2005, pp. 127-128.

QUESTION 60

Which of the following techniques can be used to segment a network?

- A.Subnetting
- B.Implementing DHCP
- C.Implementing DNS
- D.Installing hubs

Answer: A

Subnetting is used to segment a large network into smaller networks. These smaller networks can then be interconnected by using routers.

Incorrect Answers:

B:DHCP is used to automate the assignment of IP configurations to DHCP clients. It is not used to segment networks.

C:DNS is used for host name to IP address resolution and vice versa. It is not used to segment networks.

D:Hubs are used to connect hosts. They do not segment networks.

References:

David Groth and Toby Skandier,Network+ Study Guide(4th Edition), Sybex,AlamedaCA, 2005, pp. 130-133, 136-137,144.

QUESTION 61

Which of the following options is a valid reason for subnetting a network?

A.To separate the network into smaller broadcast domains

B.To minimize TCP/IP (Transmission Control Protocol/Internet Protocol) conflicts

C.To convert from a DHCP (Dynamic Host Configuration Protocol) to static addresses

D.To allow reception of multicast telecom traffic

Answer: A

Subnetting is used to divide a large network into smaller network segments, minimizing network traffic.

Subnets are

interconnected by means of routers and do not allow broadcast messages to pass from one subnet to another.

Incorrect Answers:

B:Subnetting can reduce TCP/IP collisions by reducing the size of

C:Subnetting is not required for static IP addressing.

D:Subnetting is not required for multicast traffic.

References:

David Groth and Toby Skandier,Network+ Study Guide(4th Edition), Sybex,AlamedaCA, 2005, pp. 127, 130-131.

QUESTION 62

With regard to private IP (Internet Protocol) addressing, which of the following statements are NOT true?

A.Private IP (Internet Protocol) addresses may be duplicated across many networks without causing address conflicts.

B.Private IP (Internet Protocol) addresses must be obtained dynamically from the ISP (Internet Service Provider).

C.Private IP (Internet Protocol) addresses allow organizations to share a single public IP (Internet Protocol) address.

D.Large networks may be broken into several private IP (Internet Protocol) networks.

Answer: B

Private IP addresses are reserved for use on private networks. However, private networks require a public IP address

to access resources on the Internet. These public IP address, not private IP addresses, must be obtained dynamically from the ISP.

Incorrect Answers:

A:Private IP addresses are reserved for use on private networks. Therefore, these addresses may be duplicated

across

many networks without causing IP address conflicts.

C:Through the use of NAT (Network Address Translation) multiple private IP addresses in an organization can be

mapped to a single public IP address, allowing many private IP addresses to share a single public IP (Internet Protocol)

address.

D:By using subnetting, large private networks can be broken into several smaller private networks.

References:

David Groth and Toby Skandier,Network+ Study Guide(4th Edition), Sybex,AlamedaCA, 2005, pp. 125-133.

QUESTION 63

Which of the following address is an IANA (Internet Assigned Numbers Authority) private IP address?

A.19.109.220.103

B.188.209.75.46

C.192.168.54.10

D.216.127.51.121

Answer: C

There are three IANA private IP address ranges. These are 10.0.0.0 through 10.255.255.255, 172.16.0.0 through 172.31.255.255, and 192.168.0.0 through 192.168.255.255.

References:

David Groth and Toby Skandier,Network+ Study Guide(4th Edition), Sybex,AlamedaCA, 2005, pp. 127-128.

QUESTION 64

Which of the following statements describes the TCP/IP configuration of a Windows XP Professional computer that has a TCP/IP address of 169.254.1.37?

A.The computer has been configured with a static address of 169.254.1.37.

B.The computer is set for DHCP, but no DHCP server is available on the network.

C.The computer received the address from a DHCP server on the network.

D.The computer received the address from a BootP server on the network.

Answer: B

IP address 169.254.1.37 is a selfassigned

Automatic Private IP Addressing (APIPA) address. It is automatically assigned to a Windowsbased

DHCP client that fails to obtain a valid lease from a DHCP server.

Incorrect Answers:

A:The IP address 169.254.1.37 is in the 169.254.1.0 to 169.254.254.255 address space that is reserved and cannot

be assigned statically to computers.

C:DHCP is responsible for automating the assignment of IP configurations to computer systems on a TCP/IP network.

However, the IP address 169.254.1.37 is an APIPA address. It is automatically assigned to a Windowsbased DHCP

client that fails to obtain a valid lease from a DHCP server.

N10-003

D: The Bootstrap Protocol (BootP) allows DHCP to assign more than the IP addresses to client computers. It allows it to also assign DNS servers, WINS servers, default gateway addresses, subnet masks, and many other options. However, it is DHCP that does the actual assigning of these IP settings.

References:

David Groth and Toby Skandier, Network+ Study Guide (4th Edition), Sybex, Alameda CA, 2005, pp. 144, 152.
James Chellis, Paul Robichaux and Matthew Sheltz, MCSA/MCSE: Windows Server 2003 Network Infrastructure Implementation, Management, and Maintenance Study Guide, Sybex, Alameda CA, 2003, pp. 50-51.

QUESTION 65

Which of the following can be used to automatically assign IP (Internet Protocol) configuration to host computers?

- A. DNS (Domain Name Service)
- B. SNMP (Simple Network Management Protocol)
- C. SMTP (Simple Mail Transfer Protocol)
- D. DHCP (Dynamic Host Configuration Protocol)

Answer: D

DHCP is used to automate the assignment of IP configurations to host computers which are then called DHCP clients.

Incorrect Answers:

A: DNS is used for fully qualified domain name to IP Address resolution.

B: SNMP (Simple Network Management Protocol) is a communications protocol that collects information about network devices, such as hubs, routers, and bridges.

C: SMTP is a protocol used for sending email messages.

Reference:

David Groth and Toby Skandier, Network+ Study Guide (4th Edition), Sybex, Alameda CA, 2005, pp. 115, 116, 138-142, 144.

QUESTION 66

You work as a network administrator at Certkiller .com. While monitoring traffic on the Certkiller .com network you notice an abnormally high amount of DHCP traffic. How would you reduce this traffic?

- A. Configure the DHCP server to increase lease expiration time.
- B. Configure the DHCP server to decrease lease expiration time.
- C. Configure the DHCP client to increase lease expiration time
- D. Configure the DHCP client to decrease lease expiration time.

Answer: A

DHCP is responsible for automating the assignment of IP configurations to computer systems on a TCP/IP network.

Whenever a DHCP enabled client computer boots up, it broadcasts DHCP messages across the network in order to

locate a DHCP server. If a DHCP server is available, it will respond with a DHCP lease offer. When the DHCP client

N10-003

accepts a lease offer, it sends an acknowledgement to the DHCP server. This process is repeated when the DHCP client must renew its lease, which is usually after 87.5 percent of the lease expiration time has elapsed. Thus, one way to

reduce the DHCP traffic would be to reduce the frequency at which clients need to renew the DHCP leases.

Incorrect Answers:

B: Decreasing the lease expiration time will increase the frequency at which DHCP clients will need to renew the DHCP leases. This will result in an increase in DHCP traffic.

C, D: The DHCP lease expiration time can only be increased or decreased at the DHCP server, not at the DHCP client.

References:

James Chellis, Paul Robichaux and Matthew Sheltz, MCSA/MCSE: Windows Server 2003 Network Infrastructure

Implementation, Management, and Maintenance Study Guide, Sybex, Alameda CA, 2003, pp. 223-226.

QUESTION 67

You work as a network administrator at Certkiller .com. You are configuring a Microsoft Exchange server for e-mail services. The Exchange server needs to send e-mail to a partner company that uses a Novell GroupWise e-mail server. What protocol is needed to send e-mail between the two servers?

- A. CSNW (Client Service for NetWare)
- B. SMTP (Simple Mail Transfer Protocol)
- C. IPX/SPX (Internet Packet Exchange/Sequence Packet Exchange)
- D. POP3 (Post Office Protocol version 3)

Answer: B

SMTP (Simple Mail Transfer Protocol) is used for sending e-mail messages.

Incorrect Answers:

A: CSNW provides Windows interoperability with Netware. It allows a Windows workstation computer to access the services of NetWare servers. CSNW is not used to send e-mail.

C: IPX/SPX is a networking protocol suite. It is not an e-mail protocol.

D: POP3 is used to receive e-mail from the e-mail server.

References:

David Groth and Toby Skandier, Network+ Study Guide (4th Edition), Sybex, Alameda CA, 2005, pp. 78-79, 116, 207.

QUESTION 68

Which of the following protocols establishes the connection for dial-up networking on a computer running Windows?

- A. HTTP (Hypertext Transfer Protocol)
- B. Telnet
- C. PPP (Point-to-Point Protocol)
- D. SSH (Secure Shell)

Answer: C

N10-003

The PPP protocol is used to establish a connection over point-to-point links such as dial-up and dedicated leased lines.

Incorrect Answers:

A:HTTP is the protocol that is used by a web browser to communicate with web servers. It is not used for dial-up networking.

B:Telnet is a terminal emulation protocol used to provide remote logon to hosts over the network. It is not used for dial-up networking.

D:The SSH protocol is used to establish a secure Telnet session over TCP/IP. It can be used in place of utilities such as rsh, rlogin and Telnet, but is not used for dial-up networking.

References:

David Groth and Toby Skandier, Network+ Study Guide(4th Edition), Sybex, AlamedaCA, 2005, pp. 117, 297.

QUESTION 69

Which protocol is used for error reporting in IP?

- A.SMTP
- B.ICMP
- C.IGMP
- D.SNMP

Answer: B

ICMP (Internet Control Message Protocol) is used for network management and control. It provides error testing and reporting for TCP/IP.

Incorrect Answers:

A:SMTP (Simple Mail Transfer Protocol) is used for sending email messages. It does not provide error reporting.

C:IGMP (Internet Group Management Protocol) is used to manage IP multicast sessions. It does not provide error reporting.

D:SNMP (Simple Network Management Protocol) is a communications protocol that collects information about network devices, such as hubs, routers, and bridges. It does not provide error reporting.

References:

David Groth and Toby Skandier, Network+ Study Guide(4th Edition), Sybex, AlamedaCA, 2005, pp. 112-118.

QUESTION 70

Which of the following protocols encrypt data between web browsers and web servers?

- A.IPsec
- B.SSL
- C.PPTP
- D.L2TP

Answer: B

SSL (Secure Sockets Layer) provides secure Session layer connections over the Internet between a web browser

and
web server.

Incorrect Answers:

A:IPSec (IP Security) provides secure authentication and encryption over the Internet.

C:PPTP(Point-to-Point Tunneling Protocol) is used to create virtual connections across the Internet using TCP/IP and

PPP (Point-to-Point Protocol), allowing two TCP/IP networks to use the Internet as their WAN link while retaining private network security.

D:L2TP (Layer 2 Tunneling Protocol) provides support for nonTCP/IP protocols in VPNs (virtual private networks)

over the Internet, allowing two nonTCP/

IP networks to be connected via the Internet. It is a combination of Microsoft's PPTP and Cisco's L2F (Layer 2 Forwarding) technology.

References:

David Groth and Toby Skandier,Network+ Study Guide(4th Edition), Sybex,AlamedaCA, 2005, pp. 302-303, 338-339.

QUESTION 71

Which of the following standard port must be redirected from the router to the IP address to allow a remote user to log onto a corporate server using the SSH terminal from home?

A.23

B.22

C.21

D.20

Answer: B

SSH uses TCP port 22. Therefore, this port should be redirected from the router to the IP address.

Incorrect Answers:

A:Telnet uses TCP port 23.

C, D:FTP uses TCP ports 20 and 21 for data and control respectively.

References:

David Groth and Toby Skandier,Network+ Study Guide(4th Edition), Sybex,AlamedaCA, 2005, pp. 121-123.

QUESTION 72

A user enters http://www. Certkiller .com into an Internet web browser. What is the default port number for the URL?

A.21

B.23

C.80

D.110

Answer: C

Web browsers use HTTP to access web sites. The default port for HTTP is TCP port 80.

Incorrect Answers:

A:Port 21 is the default port for FTP, not HTTP.

N10-003

B:Port 23 is the default port for Telnet, not HTTP.

D:Port 110 is the default port for POP3, not HTTP.

References:

David Groth and Toby Skandier,Network+ Study Guide(4th Edition), Sybex,AlamedaCA, 2005, pp. 122-123.

QUESTION 73

Which of the following well-known TCP/IP port numbers identifies SMTP?

A.21

B.23

C.25

D.110

Answer: C

TCP port 25 is the default port for SMTP.

Incorrect Answers:

A:TCP port 21 is the default port for FTP, not SMTP.

B:TCP port 23 is the default port for Telnet, not SMTP.

D:TCP port 110 is the default port for POP3, not SMTP.

References:

David Groth and Toby Skandier,Network+ Study Guide(4th Edition), Sybex,AlamedaCA, 2005, pp. 122-123.

QUESTION 74

You work as the network engineer at Certkiller .com. You need to verify that the SMTP (Simple Mail Transfer Protocol) service is running on a remote server. On what port number should you establish a Telnet session?

A.20

B.21

C.23

D.25

Answer: D

We want to check if SMTP is running, therefore, we must check if the port SMTP uses is open. This would be TCP

port 25.

Incorrect Answers:

A, B:FTP uses TCP ports 20 and 21 for data and control respectively.

C:Telnet uses TCP port23,however, we want to check if SMTP is running. Thus we must check if the port SMTP uses

is open. This would be TCP port 25.

References:

David Groth and Toby Skandier,Network+ Study Guide(4th Edition), Sybex,AlamedaCA, 2005, pp. 121-123.

QUESTION 75

You work as network technician at Certkiller .com. While trying to access a FTP (File Transfer Protocol) server you discover that FTP (File Transfer Protocol) is being blocked by a firewall. You unblocking port 21 on the firewall, but FTP (File Transfer Protocol) stilldoesn'twork. Why?

N10-003

- A.TFTP (Trivial File Transfer Protocol) is not installed.
- B.NFS (Network File System) is not installed.
- C.Port 20 must also be unblocked.
- D.Port 22 must also be unblocked.

Answer: C

FTP uses both TCP port 21 and TCP port 20. TCP port 21 is used for control while TCP port 20 is used for data. Therefore, you should unblock both port 20 and port 21.

Incorrect Answers:

A:TFTP mainly used to boot diskless workstations and to transfer boot images to and from routers. It uses UDP port

69 and is not required for FTP.

B:NFS is used inUNIX,it is not required for FTP.

D:FTP does not use TCP port 22. SSH (Secure Shell) uses TCP port 22.

References:

David Groth and Toby Skandier,Network+ Study Guide(4th Edition), Sybex,AlamedaCA, 2005, pp. 115, 117, 121-123.

QUESTION 76

Which of the following types of server is required to resolve the name www. Certkiller .com?

- A.DHCP (Dynamic Host Configuration Protocol)
- B.DNS (Domain Name Service)
- C.WINS (Windows Internet Name Service)
- D.NAT (Network Address Translation)

Answer: B

www. Certkiller .com is a hostname. DNS is responsible for host name to IP address resolution.

Incorrect Answers:

A:DHCP is responsible for automating the assignment of IP configurations to computer systems on a TCP/IP network.

It is not used for name resolution.

C:WINS provides NetBIOS name to IP address resolution in Windows. However, www. Certkiller .com is a host name

and not a NetBIOS name.

D:NAT allows multiple private IP addresses to be mapped to a single public IP address, and allows hosts on a private

network to connect to the Internet. It does not provide name resolution.

References:

David Groth and Toby Skandier,Network+ Study Guide(4th Edition), Sybex,AlamedaCA, 2005, pp. 136-144, 245.

QUESTION 77

Which of the following provides NetBIOS (Network Basic Input/Output System) name to IP (Internet Protocol) address resolution?

- A.ipconfig
- B.LMHOSTS

C.DNS (Domain Name Services)
D.DHCP (Dynamic Host Configuration Protocol)

Answer: B

LMHOSTS and WINS provides NetBIOS name to IP address resolution.

Incorrect Answers:

A:ipconfig displays the current TCP/IP configuration, including the current IP address, DNS configuration, WINS

configuration, and default gateway, on a computer. (188190)

C:DNS provides host name to IP address resolution, not NetBIOS name to IP address resolution.

D:DHCP is responsible for automating the assignment of IP configurations to computer systems on a TCP/IP network.

It does not provide name resolution.

References:

David Groth and Toby Skandier,Network+ Study Guide(4th Edition), Sybex,AlamedaCA, 2005, pp. 136144, 188-190.

QUESTION 78

You work as the network administrator at Certkiller .com. You setup a new mail server in a new domain on the Certkiller .com network. Which DNS records must be created before email can be received from the Internet?

A.A record only.

B.MX (Mail Exchanger) records only.

C.MX (Mail Exchanger) and CNAME (Canonical Name) records.

D.MX (Mail Exchanger) and A records.

Answer: D

The MX record points to the mail exchanger for a particular host. This ensures that email for a particular host will go to

the correct mail exchanger. However, email

addresses use host names but computers user IP addresses. Therefore, we

also need to translate host names to IP addresses. The A (Address) record maps a host name to an IP address.

Incorrect Answers:

A:The A (Address) record maps a host name to an IP address. It does not point to the mail exchanger of the host.

B:The MX record points to the mail exchanger for a particular host. This ensures that email for a particular host will go to

the correct mail exchanger. However, email

addresses use host names but computers user IP addresses. Therefore, we

also need to translate host names to IP addresses. The A (Address) record maps a host name to an IP address.

C:The MX record points to the mail exchanger for a particular host. This ensures that email for a particular host will go

to the correct mail exchanger. However, the CNAME record allows hosts to have more than one name and is not

required for mail delivery.

References:

David Groth and Toby Skandier, Network+ Study Guide (4th Edition), Sybex, Alameda CA, 2005, pp. 138-142.

QUESTION 79

Which of the following are NOT valid WEP (Wired Equivalent Privacy) key lengths?

- A. 32 bit
- B. 40 bit
- C. 64 bit
- D. 128 bit

Answer: A

WEP keys can be 40, 64, or 128 bits long, but not 32 bits long.

Reference:

David Groth and Toby Skandier, Network+ Study Guide (4th Edition), Sybex, Alameda CA, 2005, p. 339.

QUESTION 80

In Mac OS X Server 10.3, shared files and folder permissions can be set to default to _____

- A. CIFS (Common Internet File System) permissions.
- B. NTFS (New Technology File System) permissions.
- C. MAC OS 9 permissions.
- D. Standard UNIX permissions.

Answer: D

Mac OS X is based on the UNIX kernel. As such, it uses UNIX file and folder permissions.

Incorrect Answers:

A: CIFS is part of Samba and provides interoperability between UNIX/Linux servers and Windows clients.

B: NTFS is used in Windows NT. It is not used in Mac OS.

References:

David Groth and Toby Skandier, Network+ Study Guide (4th Edition), Sybex, Alameda CA, 2005, p. 120, 220.

Lon Poole and Dennis R. Cohen, Macworld Mac OS X Bible: Covers Version 10.1, Hungry Minds, New York, 2002, pp. 775-777.

QUESTION 81

Which of the following is the directory technology used by Mac OS X?

- A. iDirectory
- B. eDirectory
- C. Active Directory
- D. Open Directory

Answer: D

QUESTION 82

You work as the network administrator at Certkiller .com. You need to ensure that user can access a share hosted on a Mac OS X server. What must you enable on the Mac OS X server to allow Windows users to connect to shares?

N10-003

- A.AFP
- B.VPN
- C.Windows file and print sharing
- D.DHCP

Answer: C

Incorrect Answers:

D:DHCP is responsible for automating the assignment of IP configurations to computer systems on a TCP/IP network.

It is not responsible to interoperability between Windows and Mac OS X.

References:

David Groth and Toby Skandier,Network+ Study Guide(4th Edition), Sybex,AlamedaCA, 2005, pp. 89-90, 120.

QUESTION 83

How many concurrent connections can a Windows 2000 Professional computer support on a single share?

- A.10
- B.20
- C.30
- D.50

Answer: A

Windows 2000 Professional can have a maximum of 10 simultaneous connections.

References:

Microsoft Official Curriculum,Implementing Microsoft Windows 2000 Professional and Server Workbook, Course

Number: 2152B, Part Number: X05-78414,Module 1: Installing or Upgrading to Windows 2000, 2000, p. 10.

Microsoft Official Curriculum,Implementing Microsoft Windows 2000 Professional and Server Workbook, Course

Number: 2152B, Part Number: X05-78414,Module 7: Providing Network Access to File Resources, 2000, p. 6.

QUESTION 84

You work as a network administrator at Certkiller .com. The Certkiller network has a single Linux server. You need to enable file shares for Windows clients on the Linux server. What network service or daemon must you enable?

- A.BIND
- B.SMB
- C.DHCP
- D.LDAP

Answer: B

SMB is protocol that provides a set of connections, access f

open-source protocol suite that allows interoperability between Linux/UNIX and Windows-based clients.

Incorrect Answers:

A:BIND is found in Novell NetWare, not Linux.

C:DHCP provides IP configurations for hosts on a TCP/IP network.

D:LDAP is a protocol used to access the AD database.

References:

David Groth and Toby Skandier, Network+ Study Guide (4th Edition), Sybex, Alameda CA, 2005, pp. 120.

QUESTION 85

Which UNIX service provides interoperability with Windows file and print sharing?

- A. Mozilla
- B. NFS (Network File Service)
- C. SMB (Server Message Block)
- D. TCL (Terminal Control Language)

Answer: C

SMB is a protocol that provides a set of connections, access f

open-source protocol suite that allows interoperability between UNIX and Windows-based clients.

Incorrect Answers:

A: Mozilla is a web browser. It does not provide file and print sharing

B: The NFS (Network File System) provides file sharing across a UNIX network. NFS is also supported on a number of nonUNIX

platforms such as Windows and Macintosh. However, it does not provide printer sharing.

References:

David Groth and Toby Skandier, Network+ Study Guide (4th Edition), Sybex, Alameda CA, 2005, pp. 120.

Steve Maxwell, UNIX System Administration: A Beginner's Guide, McGrawHill/

Osborne, New York, 2002, p. 512.

QUESTION 86

With regard to NDS (NetWare Directory Services) configuration, which of the following is true?

- A. Remote users can access the tree through dial-in connections.
- B. Mobile users do not require changing the NDS (NetWare Directory Services) name context.
- C. Remote users do not require a special NDS (NetWare Directory Services) object entry.
- D. There are no differences between mobile users and remote users.

Answer: A

QUESTION 87

You work as a network administrator at Certkiller .com. You need to configure a UNIX remote access connection. Which of the following files must you edit?

- A. Devices and dialers
- B. Users and servers
- C. Hosts and security
- D. Syslogs and crontab

Answer: A

QUESTION 88

In a Windows Server 2003 AD (Active Directory) network, which server stores information about resource

objects?

- A.Domain master
- B.Domain tree
- C.Domain controller
- D.Domain configuration

Answer: C

In Windows 2000 and Windows Server 2003, information about network resources are stored in a database called

Active Directory. This Active Directory database exists on all domain controllers in the network.

Incorrect Answers:

- A: In Windows Server 2003, the domain master is responsible for naming domains that are added to the network
- B: A domain tree is a hierarchical collection of domains and sub domains that are related to a root domain.
- D: A domain configuration describes the setup of the domain. This is not a physical location.

Reference:

Michael Cross, Jeffery

A. Martin and Todd

A. Walls, MCSE Exam 70-294: Planning, Implementing, and Maintaining a Windows Server 2003, Syngress, Rockland MA, 2003, pp. 19-24, 259, 505-509.

QUESTION 89

Which of the following will enable Windows 2000 clients to access a UNIX server?

- A. Install TCP/IP (Transmission Control Protocol/Internet Protocol) on the UNIX server
- B. Install TCP/IP (Transmission Control Protocol/Internet Protocol) on the Windows 2000 clients
- C. Install Samba on the UNIX server
- D. Install Samba on the Windows 2000 clients

Answer: C

Samba allow interoperability between Windows clients and Linux/UNIX servers by using TCP/IP installed on the host

server to allow that host to interact with a Windows client or server as if the host server were a Windows file and print server.

Incorrect Answers:

- A, B: TCP/IP is the default protocol suite on both UNIX and Windows, and is installed on both by default.
- D: Samba uses TCP/IP to allow interoperability between Windows clients and Linux/UNIX servers. However, it is installed on the Linux/UNIX server, not the Windows clients.

References:

David Groth and Toby Skandier, Network+ Study Guide (4th Edition), Sybex, Alameda CA, 2005, p. 120.

QUESTION 90

You work as the network administrator at Certkiller .com. You need to setup a laptop to allow remote access to the corporate network via a secure connection through the Internet. What should you do to the laptop to enable the connection?

- A. Install AV (Anti-Virus) software with the latest definitions

N10-003

- B. Install firewall software
- C. Create a PPTP (Pont-to-Pont Tunneling Protocol) connection
- D. Install a NetBEUI (Network Basic Input/Output Extended User Interface) protocol

Answer: C

The PPTP protocol is based on PPP and is used to create a secure virtual connection across the Internet. In essence, it creates a tunnel through the Internet, providing access to the corporate network while retaining network security.

Incorrect Answers:

A: AV software will not secure the connection. It will only prevent the laptop from being infected by known viruses and other malicious software.

B: A f

will not establish a secure connection to the corporate network.

D: The NetBEUI protocol provides support for NetBIOS networks. It does not provide secure connections via the Internet.

References:

David Groth and Toby Skandier, Network+ Study Guide (4th Edition), Sybex, Alameda CA, 2005, pp. 36-37, 86, 302-304, 392-393.

QUESTION 91

When installed on a Windows 2000 server, which of the following allows a Windows-only client to access files on a NetWare 4.1 server?

- A. CSNW (Client Service for NetWare)
- B. GSNW (Gateway Service for NetWare)
- C. Novell NetWare client
- D. DNS (Domain Name Service)

Answer: B

GSNW is a Windows service that is installed on a Windows Server and allows Windows clients to connect through the Windows server to resources on a NetWare server.

Incorrect Answers:

A: CSNW allows a Windows client to access resources on a NetWare server, but must be installed on the Windows client, rather than on a Windows server.

C: The Novell NetWare client provides full NDS interoperability for other operating systems. However, this software is not available for NetWare 4.1. It was introduced with NetWare 4.11.

D: DNS is responsible for host name to IP address resolution. It does not provide interoperability between Windows and NetWare.

Reference:

David Groth and Toby Skandier, Network+ Study Guide (4th Edition), Sybex, Alameda CA, 2005, pp. 138-139, 206-207, 210.

QUESTION 92

Which protocol can you enable for Apple File Service browsing from Server Admin in Mac OS X Server 10.3?

- A. L2TP (Layer 2 Tunneling Protocol)
- B. SLIP (Serial Line Internet Protocol)
- C. NetBIOS (Network Basic Input / Output System)
- D. Rendezvous

Answer: D

You can use Mac OS X Server's Server Admin utility to enable Apple File Service browsing via Network Service

Locator (NSL) and Rendezvous. The latter is an open service discovery protocol that allows devices to be added to

and removed from networks without configuration.

Incorrect Answers:

A: L2TP is a combination of the Microsoft Point-to-Point Tunneling Protocol (PPTP) and Cisco's Layer 2 Forwarding

(L2F) technology. It is designed to support non-TCP/IP protocols in virtual private networks (VPNs) over the Internet.

B: SLIP is used to transmit TCP/IP traffic over a serial connection such as a modem and is used primarily to connect

TCP/IP clients to the Internet or other network.

C: NetBIOS is designed to manage data exchange and network access.

Reference:

David Groth and Toby Skandier, Network+ Study Guide (4th Edition), Sybex, Alameda CA, 2005, pp. 89, 142-143, 296-297, 338, 471.

QUESTION 93

What does a client require in order to share resources in a Windows network?

- A. Mapped to the resources using the host name, followed by the resource name.
- B. Allowed permission to the resources.
- C. Be a member of AD (Active Directory)
- D. Be listed in DNS (Domain Name Service)

Answer: B

A client cannot share resources on a wired network that it does not have access to, and access is controlled through

permissions. Thus, a client needs permissions to a resource before they can share that resource.

Incorrect Answers:

A: The mapping of resources is accomplished through AD and DNS. Therefore, the client does not need to map the

resource by host name and resource name.

C:AD is a database. It is not a group to which a client can have membership. However, the client must have a user

account in AD.

D:DNS is used for name resolution, not for sharing of resources.

References:

David Groth and Toby Skandier, Network+ Study Guide (4th Edition), Sybex, Alameda CA, 2005, pp. 138-142, 204-208.

QUESTION 94

Which of the following options are the minimal settings for connecting a computer to a TCP / IP (Transmission Control Protocol / Internet Protocol) LAN (Local Area Network) while accessing the Internet?

A. IP (Internet Protocol) address, subnet mask, gateway, and DNS (Domain Name Service)

B. IP (Internet Protocol) address and gateway

C. Subnet mask, IP (Internet Protocol) address, and DNS (Domain Name Service)

D. IP (Internet Protocol) address, DNS (Domain Name Service), and gateway

Answer: A

Every host on a TCP/IP network needs a unique IP address and a subnet mask. To connect to the Internet, the host

also needs a gateway, which is an intermediate device that provides connectivity to an external or dissimilar network. To

be able to reach hosts on the internet, the host will need DNS to resolve host names to IP addresses.

Incorrect Answers:

B: The host also needs a subnet mask, and a gateway, which provides connectivity to an external, dissimilar network.

C: The host needs a gateway, which provides connectivity to an external, dissimilar network.

D: The host also needs a subnet mask.

References:

David Groth and Toby Skandier, Network+ Study Guide (4th Edition), Sybex, Alameda CA, 2005, pp. 33, 125-131, 136, 138-139, 145-147.

QUESTION 95

You work as a technician at Certkiller .com. You are assisting their senior technician with terminating a line that is extending the demarcation point for a new DSL (Digital Subscriber Line) circuit. Which tool would you need?

A. A multimeter

B. An optical tester

C. A punch down tool

D. A BERT (Bit-Error Rate Test)

Answer: C

Terminating a line is the process of cutting the actual wires in the cable and inserting them into an IDC (insulation

N10-003

displacement connector). IDCs make contact by cutting through, or displacing, the insulation around a single wire. A

punchdown tool is used to insert the wire in the IDC.

Incorrect Answers:

A:A multimeter is a device that is used to measure voltages and resistances in electronic components. It is not used to

terminate DSL lines.

B:An optical tester is a device that measures the quality of strength of light signals passing through an optical cable.

D:The bit error rate is the percentage of bits that have errors relative to the total number of bits received in a transmission. This indicates how often a data unit has to be retransmitted because of an error. A BERT (bit error rate

test or tester) is a device that measures the bit error rate for a given transmission.

References:

David Groth and Dan Newland,A+Complete Study Guide(2nd Edition), Sybex,AlamedaCA, 2001, pp. 30-34.

David Groth and Toby Skandier,Network+ Study Guide(4th Edition), Sybex,AlamedaCA, 2005, pp. 270, 271-272.

<http://www.auditmypc.com/acronym/BERT.asp>

QUESTION 96

Which of the following tools can be used to test the continuity of a cable?

A.Data analyzer

B.BERT (Bit-Error Rate Test)

C.TDR (Time-Domain Reflectometer)

D.Protocol analyzer

Answer: C

A TDR, which is also called a cable tester, is a device that sends out a signal and measures the time it takes for the

signal to return. A break in the cable will cause the signal to return prematurely and will indicate the presence of, and the

distance to, a break in the cable.

Incorrect Answers:

A:Data analysis generally refers to data analysis in databases. However, data transmitted over a network is done so in

the form of packets and frames.

B:The bit error rate is the percentage of bits that have errors relative to the total number of bits received in a transmission. This indicates how often a data unit has to be retransmitted because of an error. A BERT (bit error rate

test or tester) is a device that measures the bit error rate for a given transmission.

D:A protocol analyzer is software that analyzes and displays the packets it receives from protocols that operate at the four

lower layers of the OSI model.

References:

David Groth and Toby Skandier,Network+ Study Guide(4th Edition), Sybex,AlamedaCA, 2005, pp. 12, 439.

<http://www.auditmypc.com/acronym/BERT.asp>

QUESTION 97

Which of the following functions does RADIUS (Remote Authentication Dial-In User Service) provide for remote access?

- A.Verification
- B.Encryption
- C.Addressing
- D.Tunneling

Answer: A

RADIUS is an authentication technique for remote access. It verifies the user credentials of remote users who attempt to authenticate to the network.

Incorrect Answers:

A, C, D:RADIUS does not provide encryption, addressing or tunneling.

References:

David Groth and Toby Skandier,Network+ Study Guide(4th Edition), Sybex,AlamedaCA, 2005, p. 341.

QUESTION 98

A workstation is configured for dialin connectivity to a remote access server. Which information does the client need to authenticate?

- A.Username and password
- B.IP (Internet Protocol) address and password
- C.IPX (Internet Packet Exchange) address and username
- D.Domain name and password

Answer: A

A username and password is used for authentication purposes.

Incorrect Answers:

A, B, C:The IP address, IPX address, or domain name is not used for authentication, only the username and password.

References:

David Groth and Toby Skandier,Network+ Study Guide(4th Edition), Sybex,AlamedaCA, 2005, pp. 207, 211, 217, 222.

QUESTION 99

How does PAP secure PPP sessions?

- A.By adding a secret key to the password.
- B.By adding a secret key to the username password.
- C.By double encrypting the username and password.
- D.By passing a username and password in plaintext.

Answer: D

PAP is an authentication scheme that transmits username and password unencrypted, in plaintext.

N10-003

Incorrect Answers:

A, B:PAP does not add secret keys to either the username or password.

C:PAP sends username and passwords in plaintext, i.e., with no encryption.

References:

David Groth and Toby Skandier,Network+ Study Guide(4th Edition), Sybex,AlamedaCA, 2005, p. 340.

QUESTION 100

Which of the following authentication protocols requires the use of an NTP server to synchronize the workstations date and time with the server?

- A.Kerberos
- B.RADIUS
- C.PAP
- D.MSCHAP

Answer: A

NTP is required for Kerberos.

Note:You could argue for B as well.

QUESTION 101

Which of the following UNIX commands is used for terminal emulation?

- A.route
- B.emacs
- C.rlogin
- D.ifconfig

Answer: C

The rlogin command connects your terminal on the local host to the remote host and acts as a virtual terminal to the remote system.

Incorrect Answers:

A:route is used to display the IP routing table

B:emacs is a text file editor that can be used to write and edit text files, such as documents or Pascal code.

D:ifconfig is used to display the IP configuration of the computer and is the equivalent of ipconfig in Windows 2000 and winipcfg in Windows 98.

Reference:

David Groth and Toby Skandier,Network+ Study Guide(4th Edition), Sybex,AlamedaCA, 2005, pp. 190.

[http://eswww.](http://eswww.bu.edu/help/unix/using_emacs.html)

[bu.edu/help/unix/using_emacs.html](http://eswww.bu.edu/help/unix/using_emacs.html)

<http://www.computerhope.com/unix/urlogin.htm>

http://linux.about.com/od/commands/l/blcmdl8_route.htm

QUESTION 102

In a Novel Netware 6.0 network, which type of server is used for authentication and also stores information about network resources?

- A.NDS (NetWare Directory Services)

- B.NWLINK
- C.Kerberos
- D.NLM (NetWare Loadable Module)

Answer: A

NDS is a hierarchical directory service that stores information about network resources and is also responsible for processing authentication requests.

Incorrect Answers:

B:NWLINK is a Microsoft developed protocol designed to provide compatibility with IPX/SPX.

C:Novell NetWare does not support Kerberos.

D:An NLM is a module that can be loaded on a Novell Server, providing it with additional functionality.

Reference:

David Groth and Toby Skandier, Network+ Study Guide(4th Edition), Sybex, AlamedaCA, 2005, pp. 211-212, 471.

QUESTION 103

On a Novell 5.0 server, which folder in the default directory is globally accessible by default?

- A.Sys:users
- B.Sys:apps
- C.Sys:system
- D.Sys:shared

Answer: D

In Novell Netware, the volume name ends with a colon (:). The default volume name of the system volume is Sys:.

The top level folders or directories on the volume follow the colon. The default shared folder is Sys:shared. This folder is

globally accessible on the network.

Incorrect Answers:

A:The Sys:userfolder is used to store user files and is not globally accessible by default.

B:The Sys:appsfolder is used to store files and folders for applications on the server and is not globally accessible by default.

C:The Sys:systemfolder is used to store system files and is not globally accessible by default.

QUESTION 104

On a Windows network, how are credentials supplied when a user access a Windows Network resource?

- A.Through the use of a cookie.
- B.Through the use of a cache.
- C.Through the use of a token.
- D.Through the use of a key file.

Answer: C

Windows network uses the Single Logon principle, which allows a user to authenticate once when they logon to the

N10-003

network and not have to provide their credentials for every network resource they want to access. This made possible by the use of a ticket or token that is given to each user that is successfully authenticated. The ticket is then used to access network resources.

Incorrect Answers:

A: A cookie is not really an authentication mechanism. It allows Web designers to store information about the Web site visitor that can be retrieved each time the visitor returns to the Web site as long as the visitor uses the same Web browser and computer system when they access the Web site.

Reference:

David Groth and Toby Skandier, Network+ Study Guide (4th Edition), Sybex, Alameda CA, 2005, pp. 207, 339.
Kris Jamsa, Konrad King and Andy Anderson, HTML & Web Design: Tips & Techniques, McGraw-Hill/Osborne, New York, 2002, p. 402.

QUESTION 105

You work as a network administrator at Certkiller .com. You install a firewall on a server now a client is no longer able to access files shared on that server. What should you do to resolve this problem?

- A. Change the IP (Internet Protocol) address on the client computer.
- B. Reboot the client computer and try connecting again.
- C. Reboot the server.
- D. Unblock the necessary ports.

Answer: D

A firewall filters inbound and outbound traffic based on protocol and port used by the protocol. Therefore, we should ensure that the appropriate ports are open on the firewall to permit communication.

Incorrect Answers:

A: Adding a firewall to a server will not affect IP addressing.

B, C: Communication is being blocked by the firewall, rebooting the client or the server will not open the firewall.

References:

David Groth and Toby Skandier, Network+ Study Guide (4th Edition), Sybex, Alameda CA, 2005, pp. 331-343.

QUESTION 106

Which of the following can be used to cache web pages for future retrieval?

- A. Switch
- B. Web server
- C. Repeater
- D. Proxy service

Answer: D

A proxy server caches web pages for future retrieval, allowing a user's request to be filled quicker and reducing Internet

traffic.

Incorrect Answers:

A:A Switch connects computers together to form a LAN. It does not provide caching of web pages.

B:A web server hosts the actual web sites. It does not provide caching of other web pages.

C:A repeater amplifies the signals and is used to extend the maximum length of a network segment. It does not provide caching of web pages.

References:

David Groth and Toby Skandier,Network+ Study Guide(4th Edition), Sybex,AlamedaCA, 2005, pp. 6, 56, 67-69, 136.

QUESTION 107

You work as a network administrator at Certkiller .com. You need to reduce the bandwidth used between Certkiller and the Internet. Which of the following could be implemented to accomplish this?

- A.WINS (Windows Internet Name Service) server
- B.Proxy server
- C.DHCP (Dynamic Host Configuration Protocol) server
- D.HTTP (Hypertext Transfer Protocol) server

Answer: B

A proxy server handles traffic to the Internet on behalf of the clients on the internal network. It can be configured to

control which the Internet requests can be permitted and which will be denied. This will control which web sites users

can access and which they cannot, reducing Internet bandwidth usage.

Incorrect Answers:

A:A WINS server is used for NetBIOS name resolution in a Windows network.

C:A DHCP server is used to automatically assign TCP/IP configurations to hosts on a network.

D:An HTTP server is a web server that is used to host web sites.

Reference:

David Groth and Toby Skandier,Network+ Study Guide(4th Edition), Sybex,AlamedaCA, 2005, pp. 134-13, 142-144.

QUESTION 108

You work as a network administrator at Certkiller .com. The IT department is experimenting with a new DHCP server. Which of the following actions would ensure that the DHCP server does not impact on clients from other departments?

- A.Create a new subnet for the IT department.
- B.Add a hub for the IT department.
- C.Enable IPX / SPX on the DHCP server.
- D.Ensure NetBEUI is not installed on the DHCP server.

Answer: A

Incorrect Answers:

C:DHCP automates the assignment of IP configurations to computer systems on a TCP/IP network, not on an

N10-003

IPX/SPX network. Thus installing IPX/SPX will have not affect on the DHCP function.

References:

David Groth and Toby Skandier,Network+ Study Guide(4th Edition), Sybex,AlamedaCA, 2005, pp.

QUESTION 109

You work as an administrator at Certkiller .com. You implement packet filtering on the router between the finance department and the marketing department. The following night, a batch script runs that sends a file from the marketing server to the finance FTP (File Transfer Protocol) server, but it does not work. What should be done?

- A.You should make sure port 21 is open on the router.
- B.You should change the batch script to run during the day.
- C.You should make sure ICMP (Internet Control Message Protocol) is enabled on the router.
- D.You should set the batch script to run with elevated privileges.

Answer: A

FTP uses TCP ports 20 and 21 for data and control respectively. Therefore, you should ensure that these ports are open on the router.

Incorrect Answers:

B:The time at which the batch script would not affect the

C:ICMP is a Network Layer protocol used for Network Layer management and control, while FTP is an Application

Layer protocol. The two will not affect each other.

D:The permissions on the script could affect its operation. However, we should first check if both FTP ports are open.

References:

David Groth and Toby Skandier,Network+ Study Guide(4th Edition), Sybex,AlamedaCA, 2005, pp. 112, 121-123.

QUESTION 110

You work as a network engineer at Certkiller .com. You have just implemented two VLANs (Virtual Local Area Network) on a switch. Which device will be required to pass traffic among the VLANs (Virtual Local Area Network)?

- A.Router
- B.No additional device needed
- C.Another switch
- D.A hub

Answer: A

VLAN-capable switches use the switch management software to segment a network within the switch itself.

This saves

you the expense of additional network hardware or recabling. However, each VLAN corresponds to a different IP

subnet. Therefore a router is required to change the packets between VLANs, even though the destination host is

connected to the same switch.

Incorrect Answers:

B:Although VLANs saves you the expense of additional network hardware or recabling, you do need a router, because each VLAN corresponds to a different IP subnet. Therefore a router is required to change the packets between VLANs.

C, D:A VLAN is created on a switch by assigning ports to a VLAN. It does not require the use an additional switch or a hub.

References:

David Groth and Toby Skandier,Network+ Study Guide(4th Edition), Sybex,AlamedaCA, 2005, pp. 153-155.

QUESTION 111

What is the purpose of a VLAN (Virtual Local Area Network)?

- A.Enforce better security.
- B.Add more users.
- C.Limit the network bandwidth.
- D.Reduce the number of subnets.

Answer: D

VLANs allow you to configure virtual subnets on the switch itself, rather than requiring separate routers and other network equipment.

Incorrect Answers:

A:A VLAN is not a security feature.

B:VLANs allows you to move users more easily between virtual networks. It does not allow you to add more users.

C:VLANs can be used to manage and reduce bandwidth usage. It cannot be used to place a limit on network bandwidth.

Reference:

David Groth and Toby Skandier,Network+ Study Guide(4th Edition), Sybex,AlamedaCA, 2005, pp. 151-153.
Kennedy Clark,Cisco LAN Switching(CCIE Professional Development), Cisco Press,IndianapolisIN, 1999, pp. 163-164.

QUESTION 112

The Certkiller Human Resources department requires an internal web site designed to be accessible to an external recruiting agency to update job postings. Which of the following terms describe the web site function?

- A.Intranet
- B.Internet
- C.Extranet
- D.Homepage

Answer: C

An extranet is similar to an intranet, which is made up of all networks under a single administrative control. The exception is that an extranet is and expansion of the intranet to include a few external or outside networks.

Incorrect Answers:

N10-003

A: An intranet is made up of all networks under a single administrative control and can be thought of as an internal internetwork. Thus resources made available to intranet users are only available to users on that internetwork. In this scenario we want an internal web site to be accessible to an external recruiting agency. The external recruiting agency's network will not be under the control of the administrator of the internal internetwork. Therefore, this cannot be an intranet.

B: The Internet is a global commercial conglomerate of TCP/IP internetworks that is often referred to as the World Wide Web (WWW).

D: A homepage is the default Web page that the web browser opens when you start the browser.

Reference:

David Groth and Toby Skandier, Network+ Study Guide (4th Edition), Sybex, Alameda CA, 2005, p. 104.

QUESTION 113

Certkiller .com wants to outsource the installation of an internal web server with access to employees only. Which of the following terms best describes this web server?

- A. Extranet server
- B. VPN (Virtual Private Network) server
- C. RADIUS (Remote Authentic Dial-In Service) server
- D. Intranet server

Answer: D

An intranet is made up of all networks under a single administrative control and can be thought of as an internal internetwork. Thus resources made available to intranet users are only available to users on that internetwork. In this scenario we want an internal web server to be accessible to employees only. This would be an intranet server.

Incorrect Answers:

A: An extranet is similar to an intranet, which is made up of all networks under a single administrative control. The

exception is that an extranet is an expansion of the intranet to include a few external or outside networks. In this

scenario we want an internal web server to be accessible to employees only, and not to outside users.

B: A VPN is a connection between two systems that uses the Internet as its backbone.

C: A RADIUS server is an authentication server used to authenticate remote dialup connections.

Reference:

David Groth and Toby Skandier, Network+ Study Guide (4th Edition), Sybex, Alameda CA, 2005, pp. 104, 302-304, 341.

QUESTION 114

The AV (AntiVirus)

software provides optimum protection on a network when it is installed on all _____

N10-003

- A. workstations connected to the Internet.
- B. servers.
- C. workstations and servers.
- D. workstations with disk drives.

Answer: C

To provide optimum protection on the network, you should ensure that all systems, workstations and servers included, have AV software installed on them.

Incorrect Answers:

A: Installing AV software on only the workstations connected to the internet will leave the other workstations and servers vulnerable to LAN based viruses that can be introduced to the network through disk drives.

B: Installing AV software on only the servers will leave all workstations vulnerable to LAN based viruses that can be introduced to the network through disk drives and Internet based viruses.

D: Installing AV software on only the workstations with disk drives will leave the other workstations and servers vulnerable to Internet based viruses.

References:

David Groth and Toby Skandier, Network+ Study Guide (4th Edition), Sybex, Alameda CA, 2005, pp. 392-394.

QUESTION 115

In order to maximize uptime during a brownout, what type of UPS (Uninterruptible Power Supply) should be implemented?

- A. Surge
- B. Online
- C. Spike
- D. Standby

Answer: B

An online UPS, also called 'true' UPS, provides continuous power to the computer from its battery pack which is continually charged by an inverter running off the mains power supply. During a brown out, which is a short power

Incorrect Answers:

A: A surge protector controls the amount of voltage, current (amps), and noise that can get through to your computer.

They are designed to protect the computer against long lasting increases in voltage, which are called surges, and short

bursts of high voltage, which are called spikes. However, a surge protector does not provide power of its own.

C: A spike is a short burst of high voltage. It is not a type of UPS.

D: A standby UPS uses switching technology to switch the system from DC current to its battery pack when the power

level drops below a predefined voltage. However, the switching requires a short period of time during which the computer will have no power. This could lead to erratic computer behavior.

References:

N10-003

David Groth and Toby Skandier, Network+ Study Guide (4th Edition), Sybex, Alameda CA, 2005, pp. 372-377.
<http://www.pcguides.com/ref/power/ext/ups/typesOnline-c.html>

QUESTION 116

You work as a network administrator at Certkiller .com. You are required to provide fault-tolerant electrical power for the data center. Which one of these devices should you install?

- A. A tone generator
- B. A diesel-powered generator
- C. An automobile generator
- D. A signal generator

Answer: B

You can use UPS (uninterruptible power supplies), as well as gas or diesel-powered generators to provide fault-tolerant electrical power.

Incorrect Answers:

A, D: A tone generator and a signal generator are used to test cables. They do not provide fault-tolerant electrical power.

C: An automobile generator, also known as an alternator, provides AC current of a low voltage (12-24 V). Computer systems use DC current of a higher voltage.

References:

David Groth and Toby Skandier, Network+ Study Guide (4th Edition), Sybex, Alameda CA, 2005, pp. 372-373, 438.

QUESTION 117

What is the desired result when implementing fault tolerance?

- A. It maintains standards within the IEEE (Institute of Electrical and Electronics Engineers)
- B. It completely eliminates all faults
- C. It ensures production is not impacted in the event of a failure
- D. It improves throughput

Answer: C

Fault tolerance describes a system's ability to respond to computer and network problems automatically and thus reducing the impact on the system. Thus, the aim of fault tolerance is to ensure that a system is not adversely affected in the event of a failure.

References:

David Groth and Toby Skandier, Network+ Study Guide (4th Edition), Sybex, Alameda CA, 2005, p. 368.

QUESTION 118

Which of the following RAID (Redundant Array of Independent Disks) levels uses a disk mirroring technique to provide fault tolerance?

N10-003

- A.RAID-0 (Redundant Array of Independent Disks)
- B.RAID-1 (Redundant Array of Independent Disks)
- C.RAID-3 (Redundant Array of Independent Disks)
- D.RAID-5 (Redundant Array of Independent Disks)

Answer: B

RAID-1 is a disk fault tolerance system in which two disks are exact mirrors of each other. Should the one disk fail, the system would still be operable, the failed disk can be replaced, and the mirror rebuilt.

Incorrect Answers:

A:RAID-0 is not a fault tolerance system. It uses striping on all disks to improve performance but does not use parity to provide fault tolerance.

C:RAID-3 uses striping and parity on a dedicated drive to provide fault tolerance.

D:RAID-5 uses striping and parity drive to provide fault tolerance.

References:

David Groth and Toby Skandier,Network+ Study Guide(4th Edition), Sybex,AlamedaCA, 2005, pp. 381-382.

QUESTION 119

Which of the following do NOT represent fault-tolerant strategies?

- A.Link redundancy
- B.UPS (Uninterrupted Power Supply)
- C.Fail over
- D.X.25

Answer: D

X.25 is a Data Link Layer protocol that does not provide high reliability.

Incorrect Answers:

A:Link redundancy is the use of backup links. This is a fault tolerant feature.

B:UPS is a faulttolerant feature for the supply of power to a PC.

C:Fail over is the use of an identical but inactive device that monitors the active device for failure. On failure, the failover device becomes the active device. This is a fault tolerant feature.

Reference:

David Groth and Toby Skandier,Network+ Study Guide(4th Edition), Sybex,AlamedaCA, 2005, pp. 369-370.

QUESTION 120

Which one of the following provides a faulttolerant storage system containing five disks and a single controller that will function if a single disk fails?

- A.A striped set array without parity
- B.A RAID-0 (Redundant Array of Independent Disks) array
- C.A striped set array with parity
- D.A duplexed RAID-1 (Redundant Array of Independent Disks)

N10-003

Answer: C

A striped set array with parity provides fault tolerance for multiple disks and can have a hot or cold spare.

Incorrect Answers:

A:A striped set array without parity is not a fault tolerance system. Parity is required for fault tolerance.

B:RAID-0 is not a fault tolerance system. It uses striping on all disks to improve performance but does not use parity to provide fault tolerance.

D:RAID-1 is a disk fault tolerance system in which two disks are exact mirrors of each other. RAID-1 does not use striping or parity. Duplexing is similar to mirroring but uses separate disk controllers.

References:

David Groth and Toby Skandier,Network+ Study Guide(4th Edition), Sybex,AlamedaCA, 2005, pp. 377382.

QUESTION 121

Which of the following fault tolerant or disaster recovery implementations is the MOST expensive?

A.Cold site

B.Warm site

C.Hot site

D.Dynamic site

Answer: C

In a hot site, every computer system and every bit of information has a redundant copy. This provides 100% fault

tolerance for systems that must be up 100% of the time. Hot sites are strictly faulttolerant implementations, not disaster

recovery implementations. Budgets for this type of fault tolerant implementation are typically large because each

computer system must have a redundant copy.

Incorrect Answers:

A:Cold sites rely on back ups for data recovery. This implementation has no fault tolerance and, hence, no expense,

except for back up equipment.

B:Warm sites are not as expensive as hot sites because it requires redundant copies on critical network components,

such as servers, rather than redundant copies of all computer systems.

D:There is no dynamic site in fault tolerant or disaster recovery implementations.

References:

David Groth and Toby Skandier,Network+ Study Guide(4th Edition), Sybex,AlamedaCA, 2005, pp. 369372.

QUESTION 122

You work as the network administrator at Certkiller .com. You perform full backups on Sundays and incremental backups every day EXCEPT Sunday on the Web server. The backups start at 10 a.m. and end by 12 p.m. The Web server crashes on Wednesday night. You need to restore the Web server from backup.

Which backup sets must you use to restore the Web server?

A.Sunday full backup as well as Wednesday incremental backup.

B.Sunday full backup as well as Tuesday and Wednesday backups.

C.Sunday full backup as well as Monday, Tuesday, and Wednesday backups.

N10-003

D.Sunday full backup as well as Monday, Tuesday, Wednesday, and Thursday backups.

Answer: C

Full backups backup all the data a system, regardless of what backup was previous preformed. However, the system crashed on Wednesday night. The full backup performed on Sunday will thus not be up to date. Fortunately, incremental backups are preformed every day, other than Sunday. Incremental backups backup only the data that was added or modified since the last backup. This means that we must apply all incremental backups made between Sunday and the point of failure. Thus, we should apply the Sunday full backup as well as Monday, Tuesday, and Wednesday backups.

Incorrect Answers:

A:Incremental backups backup only the data that was added or modified since the last backup. Thus, if we restore the data from the last full backup, and the data from the last incremental backup, we will loose the data that was added or changed between Sunday and Wednesday.

B:Incremental backups backup only the data that was added or modified since the last backup. Thus, if we restore the data from the last full backup, and the data from the incremental backup performed on Tuesday and Wednesday, we will loose the data that was added or changed between Sunday and Tuesday.

D:The failure occurred on Wednesday night and the last full backup was performed on the Sunday, thus, the only Thursday backup would be from the previous week and would be out of date.

References:

David Groth and Toby Skandier,Network+ Study Guide(4th Edition), Sybex,AlamedaCA, 2005, pp. 387-390.

QUESTION 123

You work as a network administrator at Certkiller .com. Certkiller .com has a Windows network with only Windows 2000 clients. You recently added a DNS server to the network and deployed AD. Users have been instructed to update their TCP/IP configuration to ensure they will use the correct DNS server. What command should the users input?

- A.nbtstat -RR
- B.nslookup
- C.ipconfig /renew
- D.winipcfg

Answer: C

In Windows 2000, you use the ipconfig /renew command to renew the TCP/IP configuration. However, we should first run the ipconfig /release command to release the current configuration.

Incorrect Answers:

A:nbtstat rris

N10-003

used to release and refresh NetBIOS names on resource servers in the WINS database.

B:nslookup displays information about a particular domain name, the name servers that serve it, and how they are configured.

D:winipcfg is the Windows 9x version of ipconfig. However, we have only Windows 2000 clients on the network.

References:

David Groth and Toby Skandier, Network+ Study Guide (4th Edition), Sybex, Alameda CA, 2005, pp. 186-188, 194.

QUESTION 124

Which of the following utilities will identify the number of hops from a client to a destination host on a routed network?

A.nbtstat

B.nslookup/dig

C.netstat

D.tracert/traceroute

Answer: D

When troubleshooting a connection to a site, you can use tracert or traceroute to count the number of hops from the source to the destination host.

Incorrect Answers:

A:nbtstat can be used to track NetBIOS over TCP/IP statistics, display incoming and outgoing NetBIOS over TCP/IP

connections details, and resolve NetBIOS names. It does not count the number of hops between a source and destination host.

B:nslookup displays information about a particular domain name, the name servers that serve it, and how they are

configured. dig is the UNIX version of this utility. Neither counts the number of hops between a source and destination host.

C:netstat displays the inbound and outbound TCP/IP connections on a computer. It does not count the number of hops between a source and destination host.

References:

David Groth and Toby Skandier, Network+ Study Guide (4th Edition), Sybex, Alameda CA, 2005, pp. 167-180, 191, 194-195.

QUESTION 125

A user cannot reach the Certkiller .com web site, but can access other web sites. What command can be used to diagnose the problem?

A.arp

B.ipconfig

C.netstat

D.tracert

Answer: D

tracert displays a list of router interfaces that a TCP/IP packet passes through on its way to a destination, including destinations on the Internet. This list includes all the DNS names and IP addresses of the routers that the packet is passing through. It also counts the number of hops between a local computer and a destination host.

Incorrect Answers:

A:arp translates IP addresses to MAC addresses. It is primarily used for resolving duplicate IP addresses.

B:ipconfig displays the current TCP/IP configuration, including the current IP address, DNS configuration, WINS configuration, and default gateway, on a computer.

C:netstat is used to display the inbound and outbound TCP/IP connections on a local computer. It provides packet statistics, such as the number of packets that have been sent and received, the number of errors, etc.

References:

David Groth and Toby Skandier, Network+ Study Guide (4th Edition), Sybex, Alameda CA, 2005, pp. 164-169, 186-191.

QUESTION 126

You suspect that SMTP virus has infected your workstation. All your email programs are closed. Which of the following utilities could you use to see if there are any open SMTP sockets?

A.nbtstat

B.netstat

C.arp

D.nslookup

Answer: B

netstat is used to display the inbound and outbound TCP/IP connections, including SMTP connections, on a local computer. It provides packet statistics, such as the number of packets that have been sent and received, the number of errors, etc.

Incorrect Answers:

A:nbtstat is used to display NetBIOS over TCP/IP statistics, to display statistics for incoming and outgoing NetBIOS over TCP/IP connections, and to resolve NetBIOS names.

C:arp translates IP addresses to MAC addresses. It is primarily used for resolving duplicate IP addresses.

D:nslookup displays information about a particular domain name, the name servers that serve it, and how they are configured.

References:

David Groth and Toby Skandier, Network+ Study Guide (4th Edition), Sybex, Alameda CA, 2005, pp. 164-169, 174-175, 194-195.

QUESTION 127

You work as a network administrator at Certkiller .com. You notice suspicious IP traffic on the local subnet. After successfully pinging the source, which utility can you use to find the associated MAC address?

- A. ipconfig
- B. nbtstat
- C. arp
- D. tracert

Answer: C

arp translates IP addresses to MAC addresses. It displays a list of IP addresses and their corresponding MAC addresses.

Incorrect Answers:

A: ipconfig displays the current TCP/IP configuration, including the current IP address, DNS configuration, WINS

configuration, and default gateway, on a computer.

B: nbtstat is used to display NetBIOS over TCP/IP statistics, to display statistics for incoming and outgoing NetBIOS

over TCP/IP connections, and to resolve NetBIOS names.

D: tracert displays a list of router interfaces that a TCP/IP packet passes through on its way to a destination, including

destinations on the Internet. This list includes all the DNS names and IP addresses of the routers that the packet is

passing through. It also counts the number of hops between a local computer and a destination host.

References:

David Groth and Toby Skandier, Network+ Study Guide (4th Edition), Sybex, Alameda CA, 2005, pp. 164-165, 174-175, 188-191.

QUESTION 128

Which of the following commands can be used to check for duplicate IP address on a network?

- A. ping
- B. traceroute
- C. find
- D. arp

Answer: D

arp translates IP addresses to MAC addresses. It is primarily used for resolving duplicate IP addresses.

Incorrect Answers:

A: ping is used to test connectivity between two hosts. It does not indicate the duplication of IP addresses on the network.

B: traceroute displays a list of router interfaces that a TCP/IP packet passes through on its way to a destination, including

destinations on the Internet. This list includes all the DNS names and IP addresses of the routers that the packet is

passing through. It also counts the number of hops between a local computer and a destination host.

C: find is not a TCP/IP utility.

References:

David Groth and Toby Skandier, Network+ Study Guide (4th Edition), Sybex, Alameda CA, 2005, pp. 164-166, 185-186, 188-191.

QUESTION 129

Which of the following commands would display adapter names, IP (Internet Protocol) address, subnet mask, gateway, and DNS (Domain Name Service) on a Windows 98 workstation?

- A. winipcfg /all
- B. nbtstat -a
- C. nslookup -a
- D. ifconfig /all

Answer: A

winipcfg, ipconfig and ifconfig displays the current TCP/IP configuration, including the current IP address, DNS

configuration, WINS configuration, and default gateway, on a computer. winipcfg is the Windows 9x version used on

Windows 95, Windows 98 and Windows Millennium Edition clients. These commands support three switches: /all,

which displays the current TCP/IP conf

DHCP; and /renew, which requests a new TCP/IP conf

Incorrect Answers:

A: nbtstat is used to display NetBIOS over TCP/IP statistics, to display statistics for incoming and outgoing NetBIOS

over TCP/IP connections, and to resolve NetBIOS names. The a

switch displays a remote computer's NetBIOS name

table, which lists all the NetBIOS names that the remote computer knows.

C: nslookup displays information about a particular domain name, the name servers that serve it, and how they are

configured

D: ifconfig /all is the UNIX/Linux equivalent of winipcfg /all. It will provide the same information as winipcfg

/all but only on UNIX and Linux computers.

References:

David Groth and Toby Skandier, Network+ Study Guide (4th Edition), Sybex, Alameda CA, 2005, pp. 174-177, 186-190, 194-195.

QUESTION 130

What command is used to view all of the TCP/IP (Transmission Control Protocol/Internet Protocol) configuration on a Windows 98 client?

- A. ifconfig /all
- B. winipcfg /all
- C. ipconfig /TCP (Transmission Control Protocol) release
- D. winipcfg /release

Answer: B

winipcfg, ipconfig and ifconfig displays the current TCP/IP configuration, including the current IP address,

N10-003

DNS

configuration, WINS configuration, and default gateway, on a computer. winipcfg is the Windows 9x version used on Windows 95, Windows 98 and Windows Millennium Edition clients. These commands support three switches: /all, which displays the current TCP/IP configuration; /renew, which requests a new DHCP configuration; and /release, which releases the current DHCP configuration.

Incorrect Answers:

A: ipconfig is the UNIX/Linux version of winipcfg. It is used on UNIX and Linux computers, not on Windows 98 computers.

C: ipconfig is the Windows NT version of winipcfg. It is used on Windows 2000, Windows XP and Windows Server 2003 computers, not on Windows 98 computers.

D: The /release switch releases the TCP/IP configuration obtained from DHCP.

References:

David Groth and Toby Skandier, Network+ Study Guide (4th Edition), Sybex, Alameda CA, 2005, pp. 186-190.

QUESTION 131

You work as a network technician at Certkiller .com. Certkiller .com has a Windows network. You need to troubleshoot NetBIOS (Network Basic Input/Output System) over TCP/IP (Transmission Control Protocol/Internet Protocol) from Workstation1 to Workstation2. Which utility should you use?

- A. ping
- B. tracert
- C. nbtstat
- D. netstat

Answer: C

nbtstat is used to display NetBIOS over TCP/IP statistics, to display statistics for incoming and outgoing NetBIOS over TCP/IP connections, and to resolve NetBIOS names.

Incorrect Answers:

A: ping is used to test connectivity between hosts. It is not used to test NetBIOS over TCP/IP.

B: tracert displays a list of router interfaces that a TCP/IP packet passes through on its way to a destination, including destinations on the Internet. This list includes all the DNS names and IP addresses of the routers that the packet is

passing through. It also counts the number of hops between a local computer and a destination host.

C: netstat is used to display the inbound and outbound TCP/IP connections on a local computer. It provides packet statistics, such as the number of packets that have been sent and received, the number of errors, etc.

References:

David Groth and Toby Skandier, Network+ Study Guide (4th Edition), Sybex, Alameda CA, 2005, pp. 167-169, 174-177, 184-191.

QUESTION 132

Which of the following commands displays the MAC (Media Access Control) address of a given computer?

N10-003

- A.nslookup
- B.ipconfig /all
- C.nbtstat
- D.netstat

Answer: B

ipconfig /all displays the current TCP/IP configuration, including the current IP address, MAC address, DNS configuration, WINS configuration, and default gateway, on a computer. (188-190)

Incorrect Answers:

A:nslookup displays information about a particular domain name, the name servers that serve it, and how they are configured

C:nbtstat is used to display NetBIOS over TCP/IP statistics, to display statistics for incoming and outgoing NetBIOS

over TCP/IP connections, and to resolve NetBIOS names. The a switch displays a remote computer's NetBIOS name

table, which lists all the NetBIOS names that the remote computer knows. (174-177)

D:netstat is used to display the inbound and outbound TCP/IP connections on a local computer.

References:

David Groth and Toby Skandier,Network+ Study Guide(4th Edition), Sybex,AlamedaCA, 2005, pp. 174-177, 186-190,194-195.

QUESTION 133

After patching and rebooting a network DHCP (Dynamic Host Configuration Protocol) server, some clients who were able to access resources begin to lose connectivity. What utility can be used to regain connectivity to the network?

- A.nbtstat
- B.arp
- C.tracert/traceroute
- D.ipconfig/ifconfig

Answer: D

ipconfig and ifconfig displays the current TCP/IP configuration, including the current IP address, DNS configuration,

WINS configuration, and default gateway, on a computer.ipconfig is the Windows NT version while ifconfig is the

UNIX/Linux version of the utility. These commands support three switches: /all, which displays the current TCP/IP

new TCP/IP configuration from the DHCP server.

Incorrect Answers:

A:nbtstat is used to display NetBIOS over TCP/IP statistics, to display statistics for incoming and outgoing NetBIOS

over TCP/IP connections, and to resolve NetBIOS names. The a switch displays a remote computer's NetBIOS name

table, which lists all the NetBIOS names that the remote computer knows.

B:arp translates IP addresses to MAC addresses. It is primarily used for resolving duplicate IP addresses.

N10-003

C:tracert/traceroute displays a list of router interfaces that a TCP/IP packet passes through on its way to a destination, including destinations on the Internet. This list includes all the DNS names and IP addresses of the routers that the packet is passing through. It also counts the number of hops between a local computer and a destination host.
References:

David Groth and Toby Skandier, Network+ Study Guide (4th Edition), Sybex, Alameda CA, 2005, pp. 164-166, 174-177, 188-191.

QUESTION 134

Identify the utility being used given the output:

```
Interface: 206.212.36.18 on Interface 1
Internet Address Physical Address Type
206.212.36.900-00-21-64-91-12 Dynamic
206.212.36.1200-00-21-1b-4a-a7 Dynamic
```

- A. netstat
- B. arp
- C. nbtstat
- D. tracert/traceroute

Answer: B

arp translates IP addresses to MAC addresses. It is primarily used for resolving duplicate IP addresses and displays a list of IP addresses and their corresponding MAC addresses as shown in the output above.

Incorrect Answers:

A: netstat is used to display the inbound and outbound TCP/IP connections on a local computer. It provides packet statistics, such as the number of packets that have been sent and received, the number of errors, etc.

C: nbtstat is used to display NetBIOS over TCP/IP statistics, to display statistics for incoming and outgoing NetBIOS over TCP/IP connections, and to resolve NetBIOS names.

D: tracert/traceroute displays a list of router interfaces that a TCP/IP packet passes through on its way to a destination, including destinations on the Internet. This list includes all the DNS names and IP addresses of the routers that the packet is passing through. It also counts the number of hops between a local computer and a destination host.

References:

David Groth and Toby Skandier, Network+ Study Guide (4th Edition), Sybex, Alameda CA, 2005, pp. 164-169, 174-175, 191.

QUESTION 135

Given the following output, which utility was used?

```
Interface 10.10.10.1 on Interface 0x1000004
Internet
Address Physical Address Type
10.10.10.500-e0-29-62-0d-dedynamic
```

10.10.10.1100-00-08-fd-97fastatic

- A.arp
- B.traceroute
- C.ping
- D.ipconfig

Answer: A

arp translates IP addresses to MAC addresses. It is primarily used for resolving duplicate IP addresses and displays a list of IP addresses and their corresponding MAC addresses as shown in the output above.

Incorrect Answers:

B:traceroute displays a list of router interfaces that a TCP/IP packet passes through on its way to a destination, including destinations on the Internet. This list includes all the DNS names and IP addresses of the routers that the

packet is passing through. It also counts the number of hops between a local computer and a destination host.

C:ping is used to test connectivity to a remote host.

D:ipconfig displays the current TCP/IP configuration, including the current IP address, DNS configuration, WINS

configuration, and default gateway, on a computer.

References:

David Groth and Toby Skandier, Network+ Study Guide (4th Edition), Sybex, Alameda CA, 2005, pp. 164-166, 184, 188-191.

QUESTION 136

Which command generated the following output?

Active Connections

Proto Local Address Foreign Address State

TCP Certkiller 1:3006 192.168.0.2:Microsoft Established

TCP Certkiller 1:3021 192.168.0.246:HTTP Established

- A.nbtstat
- B.netstat
- C.arp
- D.ipconfig

Answer: B

netstat is used to display the inbound and outbound TCP/IP connections on a local computer, including the protocol, port number, IP address of the remote host, and the connection state.

Incorrect Answers:

A:nbtstat is used to display NetBIOS over TCP/IP statistics, to display statistics for incoming and outgoing NetBIOS over TCP/IP connections, and to resolve NetBIOS names. (174-177)

C:arp translates IP addresses to MAC addresses. It is primarily used for resolving duplicate IP addresses (164-166)

D:ipconfig displays the current TCP/IP configuration, including the current IP address, DNS configuration,

WINS

configuration, and default gateway, on a computer. (188-190)

References:

David Groth and Toby Skandier, Network+ Study Guide (4th Edition), Sybex, Alameda CA, 2005, pp. 164-169, 174-177, 188-190.

QUESTION 137

The diagnostic tool would produce the following output?

```
1 Router1 (192.168.0.1) 2.0 ms 1.0 ms 2.0 ms
2 Server.net.com (4.150.6.3) 18.0ms 12.0ms 32.0ms
3 time.net.com (2.12.14.1) 240ms 120ms 300ms
```

- A. traceroute
- B. ping
- C. ifconfig
- D. winipcfg

Answer: A

tracert displays a list of router interfaces that a TCP/IP packet passes through on its way to a destination, including destinations on the Internet. This list includes all the DNS names and IP addresses of the routers that the packet is passing through as shown in the output above.

Incorrect Answers:

B: ping is used to test connectivity between two hosts by sending an echo request to the remote host. The output from this command would indicate the replies from the remote host.

C, D: winipcfg, ipconfig and ifconfig displays the current TCP/IP configuration, including the current IP address, DNS configuration, WINS configuration, and default gateway, on a computer. winipcfg is the Windows 9x version used on

Windows 95, Windows 98 and Windows Millennium Edition clients. These commands support three switches: /all,

which displays the current TCP/IP conf

DHCP; and /renew, which requests a new TCP/IP conf

References:

David Groth and Toby Skandier, Network+ Study Guide (4th Edition), Sybex, Alameda CA, 2005, pp. 174-177, 186-190, 194-195.

QUESTION 138

A business with a DSL (Digital Subscriber Line) modem lost connectivity and the secretary changed one of the network settings to try to fix it. The settings are now:

IP address: 128.210.5.21

Subnet mask: 255.0.0.0

Gateway: 128.210.5.1

DNS server: 128.210.5.11

Given the information above, which of the following identifies the settings that has changed?

N10-003

- A.IP (Internet Protocol) address
- B.Subnet mask
- C.Gateway
- D.DNS (Domain Name Service) server

Answer: B

The IP addresses 128.210.5.21, used by the host, 128.210.5.1, used by the gateway, and 128.210.5.11, used by the DNS server, are all class B IP addresses. Class B IP addresses use the subnet mask 255.255.0.0, not 255.0.0.0, which

is used for class A IP addresses. Thus, the subnet mask is incorrect and is thus the setting that has been changed.

References:

David Groth and Toby Skandier, Network+ Study Guide (4th Edition), Sybex, Alameda CA, 2005, pp. 126-128.

QUESTION 139

You work as a network technician at Certkiller .com. You have just installed a new NIC (Network Interface Card) in a computer and attached a cable to connect the computer to a hub. If the NIC (Network Interface Card) is functioning correctly and the network is up, which of the following will you see on the NIC (Network Interface Card)?

- A.The amber light is flashing occasionally and the green light is lit steadily.
- B.The amber light is flashing continually, the green light is lit steadily, and neither light will be on until data is transferred.
- C.The amber light is lit and steady and the green light is flashing continually.
- D.The amber light is flashing occasionally, the green light is lit steadily, and neither light will be on until data is transferred.

Answer: A

and an amber light that flashes when collisions occurs. Collisions are common on an Ethernet network.

Therefore the amber light will flash occasionally.

References:

David Groth and Toby Skandier, Network+ Study Guide (4th Edition), Sybex, Alameda CA, 2005, pp. 430-431.

QUESTION 140

Which LED on a NIC should you check FIRST to identify the problem when a workstation suddenly fails to connect to the network?

- A.Link
- B.Activity
- C.Collision
- D.Power

Answer: A

When troubleshooting a network problem you should check if there is a physical connection between the NIC and the

hub or switch. The link LED on the NIC indicates that there is a connection to the network and should be the first thing

you check.

Incorrect Answers:

B,D:A NIC will not have a Power LED or an Activity LED. These are found on connectivity device such as modems, routers, hubs and switches.

C:The collision LED indicates that an Ethernet collision has occurred. This light will blink occasionally because collisions

are common on Ethernet networks. However, you should first check that there is a connection to the network.

References:

David Groth and Toby Skandier,Network+ Study Guide(4th Edition), Sybex,AlamedaCA, 2005, pp. 411-412.

QUESTION 141

You work as the network administrator at Certkiller .com. You have provided a user with full access rights to a folder share. When the user opens a file in the folder share, she finds that she cannot modify the file contents. What is the most likely cause of this problem?

- A.The group rights filter has been changed through the GPO to disallow file access.
- B.The file registered has been pulled from cache memory and is not writeable.
- C.The file has been opened by another user and is open for read only.
- D.The file has been pulled from the backup source not the tree directory.

Answer: C

QUESTION 142

You work as the network technician at Certkiller .com. You are troubleshooting a connectivity problem to the www. Certkiller .com web site. You receive a time out when you ping the web site by name. You verify the TCP/IP configuration on the local computer. You successfully ping to the default gateway and the web server by IP address.Which is the probable cause of this problem?

- A.The DNS server is down.
- B.The DHCP is down.
- C.The LAN is down.
- D.The router is down.

Answer: A

In this case you can ping the IP address but not the host name. Therefore there is a problem with host name to IP address resolution. DNS is responsible for host name to IP address resolution and is the most probable cause of the problem.

Incorrect Answers:

B:DHCP is responsible for automating the assignment of IP configurations to computer systems on a TCP/IP network.

C, D:you can ping the IP address of both the web server and the default gateway, therefore there can be no problem with the LAN or the router.

References:

N10-003

David Groth and Toby Skandier, Network+ Study Guide (4th Edition), Sybex, Alameda CA, 2005, pp. 136-144, 184.

QUESTION 143

You work as a network technician at Certkiller .com. Certkiller user complains that she can no longer attach to a server using its host name; however, she can attach to it using the IP (internet Protocol) address. Why?

- A. The server is in the wrong subnet.
- B. The server that they are trying to connect to is not registered in DHCP (Dynamic Host Configuration Protocol).
- C. The server that they are trying to connect to has lost its registration in DNS (Domain Name Service).
- D. The server that they are trying to connect to has WINS (Windows Internet Name Service) enabled.

Answer: C

DNS is responsible for the translation of host names to IP addresses. In this scenario, the user cannot ping by host name but can ping by IP address. The problem thus lies with name resolution. It is possible that the server has lost its registration in DNS.

Incorrect Answers:

A: The ping utility is used to test connectivity to a remote host. Ping traffic is able to pass through routers. Therefore the subnet on which the destination host resides is not of relevance. Also, the user is able to ping the server by IP address.

B: DHCP is used to automate the assignment of TCP/IP configurations to DHCP hosts. This configuration includes IP address, subnet mask, DNS server, WINS server and default gateway. In this scenario, the user is able to ping the server by IP address. Therefore the server has an appropriate TCP/IP configuration. Thus, the problem cannot be with DHCP leasing.

D: WINS is used for NetBIOS name to IP Address resolution. However, the user is attempting to connect to a server by host name. Host name to IP address resolution is provided by DNS.

References:

David Groth and Toby Skandier, Network+ Study Guide (4th Edition), Sybex, Alameda CA, 2005, pp. 138-144, 185-186.

QUESTION 144

You work as an administrator at Certkiller .com. An end user complains that he cannot log in to the network, although he could yesterday. Last night you replaced an ISA (Industry Standard Architecture) Token Ring NIC (Network Interface Card) with a PCI (Peripheral Component Interconnect) Token Ring NIC (Network Interface Card) in the user's computer on a 16 Mbps (Megabits per second) LAN (Local Area Network).

What should you do NEXT to resolve this problem?

- A. Check the MAU (Multistation Access Unit)
- B. Check the processor speed
- C. Check the user password
- D. Check the NIC (Network Interface Card)

N10-003

Answer: D

When troubleshooting, you should check the condition that changed first, as this is the most likely cause of the problem.

In this case we changed the NIC. Therefore, we should check the NIC to ensure that it is operating properly.

Incorrect Answers:

A:Token ring uses a logical ring topology but a physical star topology in which the MAU is the central device connecting the various stations. Thus, if there was a problem with the MAU, more than one user would be affected.

Also, you should first check the condition that changed since the system last worked, in this case, the NIC.

B:The processor did not change. It should therefore be operating at the same speed as before. Also, the processor speed has no bearing on network connectivity.

C:that changed since the system last worked, in this case, the NIC.

References:

David Groth and Toby Skandier, Network+ Study Guide (4th Edition), Sybex, Alameda CA, 2005, pp. 57-58, 65, 416-417.

QUESTION 145

You are the network administrator at Certkiller .com. A user complains that she cannot access resources on the network. The ping command from the user's computer to a server fails by both host name and IP address. When you run the ipconfig command, you receive an IP (Internet Protocol) address that is not in the correct subnet. What is the probable cause of this problem?

A.The DHCP (Dynamic Host Configuration Protocol) server has lost connection to the DNS (Domain Name Service).

B.Someone has enabled an additional DHCP (Dynamic Host Configuration Protocol) server.

C.The WINS (Windows Internet Name Service) is offline.

D.The DNS (Domain Name Service) is offline.

Answer: B

It seems a rogue DHCP server was enabled on the network. The user's computer probably received its lease from the

rogue DHCP server, which does not have the same address pool as the authorized DHCP server.

A:DNS is required for host name to IP address resolution. If the DHCP server loses connection to the DNS server, it

will not be able to lease IP addresses on the network. However, the IP addresses that have been leased will still be in place.

C, D:WINS and DNS are required for NetBIOS name to IP address resolution and host IP address resolution respectively. However, ping by IP address failed, therefore we cannot assume that the problem is related to name resolution.

References:

James Chellis, Paul Robichaux and Matthew Sheltz, MCSA/MCSE: Windows Server 2003 Network Infrastructure

Implementation, Management, and Maintenance Study Guide, Sybex, Alameda CA, 2003, pp. 229-230.

QUESTION 146

You work as an administrator at Certkiller .com. You configure DHCP (Dynamic Host Configuration Protocol) services for the network using a PDC (Primary Domain Controller) and BDC (Backup Domain Controller) each with a range of 192.168.0.1 to 192.168.0.254 and a class subnet of 255.255.255.0. However, DHCP (Dynamic Host Configuration Protocol) errors are occurring. How can these errors be resolved?

100

A.

Change the default subnet to 255.255.0.0 to increase the number of allowable IP (Internet Protocol) addresses to prevent collisions.

B.The machines are holding IP (Internet Protocol) addresses in cache memory. Reboot to renew IP (Internet Protocol) address.

C.Configure BootP (Boot Protocol) on the server when the IP (Internet Protocol) class subnets are split prior to implementing the scope.

D.Split the scope addresses between the servers assigning 192.168.0.1 through 192.168.0.127 for the PDC (Primary Domain Controller) and 192.168.0.128 through 192.168.0.254 for the BDC (Backup Domain controller).

Answer: D

In this scenario, we have two DHCP servers leasing the same IP address scope. This is the cause of the DHCP errors

as both DHCP servers are trying to lease the same addresses. We can overcome these problems by removing one of

the DHCP servers, or by splitting the IP address scope between the two.

Incorrect Answers:

A:The IP address range 192.168.0.1 through 192.168.0.127 is a class C range which uses the 255.255.255.0 subnet

mask. The subnet mask 255.255.0.0 is used for class B. Changing the subnet mask to 255.255.0.0 would thus not be

the correct option.

B:DHCP leases are held for the duration of the DHCP lease period and are not renewed every time the machine reboots. You must use the winipcfg/ipconfig/ifconfig utility to release and renew a DHCP lease.

C:BootP is required to forward DHCP traffic over a router and should be configured on the router, not the DHCP

server.

References:

James Chellis, Paul Robichaux and Matthew Sheltz,MCSA/MCSE: Windows Server 2003 Network Infrastructure

Implementation, Management, and Maintenance Study Guide, Sybex, Alameda CA, 2003, pp. 223-224, 230, 254.

David Groth and Toby Skandier,Network+ Study Guide(4th Edition), Sybex,AlamedaCA, 2005, pp. 186-190.

QUESTION 147

You cannot reach a web site on a host computer but you can ping the host name and Telnet to the host name. What is the source of the problem?

N10-003

- A.The host does not have a DNS entry.
- B.The host HTTP is down.
- C.The host does not have a WINS entry.
- D.The host is down.

Answer: B

Web browsers use HTTP to access web sites. If HTTP is down or port 80, which is used for HTTP traffic, is blocked, you won't be able to access the web site.

Incorrect Answers:

A:DNS is used to provide host name to IP Address translation, thus, if you can ping and telnet to the host name, then

there can be no problem with DNS.

C:WINS provides NetBIOS name to IP Address translation. This is not required to access a web site.

D:ping is used to test connectivity to a remote host. If the remote host is down, ping will not be successful.

References:

David Groth and Toby Skandier,Network+ Study Guide(4th Edition), Sybex,AlamedaCA, 2005, pp. 117, 136-144, 184.

QUESTION 148

You work as a network administrator at Certkiller .com. You have just added a new DNS (Domain Name Service) server to a network and removed the old DNS (Domain Name Service) server. The IP (Internet Protocol) address of the new server is different, and the DHCP (Dynamic Host Configuration Protocol) server was updated to reflect this change. Certain computers can connect to www. Certkiller .com while others cannot. Which of the following computers will be able to connect to www. Certkiller .com?

- A.Any computer that has not released and renewed their DHCP (Dynamic Host Configuration Protocol) lease.
- B.Any statically assigned workstation.
- C.Any computer that has released and renewed their DHCP (Dynamic Host Configuration Protocol) lease.
- D.Any computer that does not have a NIC (Network Interface Card)

Answer: C

Computers must release and renew their DHCP leases in order to receive the new configuration that has been updated on the DHCP server. Once they receive this new configuration, they will be able to access the new DNS server.

Incorrect Answers:

A:Computers that have

not released and renewed their DHCP leases will still be configured with the IP address for the old DNS server. Only

when they renew the DHCP leases will the computers be configured with the updated DHCP settings.

B:Computers with static IP addresses don't get their TCP/IP configurations from DHCP. Therefore they won't the

updated configurations from DHCP and will not be able to connect to the new DNS server.

D:Computers that do not have a NIC don't require an IP address as they have no network connectivity.

References:

James Chellis, Paul Robichaux and Matthew Sheltz,MCSA/MCSE: Windows Server 2003 Network

Infrastructure

Implementation, Management, and Maintenance Study Guide, Sybex, Alameda CA, 2003, pp. 223-227.

QUESTION 149

You work as a network administrator at Certkiller .com. You change the lease time of the DHCP scope from one week to one day. What affect will this have on the end users?

- A.The users will have to relogon every day now.
- B.The users will have to manually release and renew their IP addresses to continue working on the network.
- C.The users will not be affected by the change.
- D.The users will have to shut their computers down for the duration of the lease to obtain a new lease.

Answer: C

Changing the lease time will not affect the currently assigned IP configurations. The current IP settings will still be valid

but will now be renewed earlier. Thus, the users will not be affected by the change.

Incorrect Answers:

A:DHCP does not determine how often a user must relogon to the computer. It only provides IP configurations settings to the computer.

B:Changing the lease time will not affect the currently assigned IP configurations. The current IP settings will still be valid

but will now be renewed earlier.

D:This doesn't make sense in a network environment. If the lease time is increased to 30 days, no work will be done for

a month - definitely not!

References:

David Groth and Toby Skandier,Network+ Study Guide(4th Edition), Sybex,AlamedaCA, 2005, pp. 144, 154.

QUESTION 150

You work as a network administrator at Certkiller .com. Your DNS server has just suffered a catastrophic failure. What affect will this have on the DNS clients?

- A.They will be unable to renew their IP addresses.
- B.They will be unable to reference a server by host name.
- C.They will be unable to reference a server by NetBIOS name.
- D.They will be unable to renew their IPX address.

Answer: B

DNS is responsible for host name to IP address resolution. Thus, if the DNS server is down, name resolution from host

name to IP address will not be possible; thus DNS clients will not be able to ref

Incorrect Answers:

A:The DHCP server is responsible for assigning and renewing IP addresses, not the DNS server.

C:WINS is responsible for NetBIOS name to IP addresses resolution. DNS is responsible for host name to IP address resolution.

D:There is not DHCP system for IPX.

References:

David Groth and Toby Skandier,Network+ Study Guide(4th Edition), Sybex,AlamedaCA, 2005, pp. 136-142,144.

QUESTION 151

You work as the network administrator at Certkiller .com. The Certkiller network consists of two subnets: Subnet A and Subnet B. The DHCP (Dynamic Host Configuration Protocol) server in Subnet A fails. The DHCP (Dynamic Host Configuration Protocol) server in Subnet B is set with a DHCP (Dynamic Host Configuration Protocol) addresses. What needs to be done to correct this problem?

A.Install a proxy server on Subnet A

B.Install a DHCP (Dynamic Host Configuration Protocol) relay agent on a server in Subnet B

C.Install a DHCP (Dynamic Host Configuration Protocol) relay agent on the DHCP (Dynamic Host Configuration

Protocol) server in Subnet B

D.Install a DHCP (Dynamic Host Configuration Protocol) relay agent on a server in Subnet A

Answer: D

The DHCP server in Subnet A failed so we can assume that the DHCP clients on Subnet A cannot reach a DHCP

server to renew their DHCP leases. This can be overcome by installing a DHCP relay agent on the affected subnet.

Note:This is a vague question. The real problem here is that the DHCP server in Subnet B has a DHCP address but the

other DHCP server has failed. This means that the DHCP server in Subnet B cannot get a DHCP lease, unless there is

another DHCP server on the network. We should preferably configure the DHCP server with a static IP address.

Incorrect Answers:

A:A proxy server is used to protect a network from attacker on the Internet. It is not used to forward DHCP requests.

B, C:The DHCP server in Subnet A failed so we can assume that the DHCP clients on Subnet A cannot reach a DHCP server to renew their DHCP leases. This can be overcome by installing a DHCP relay agent on the network.

However, the DHCP relay agent should be installed on the affected Subnet, not Subnet B.

References:

James Chellis, Paul Robichaux and Matthew Sheltz,MCSA/MCSE: Windows Server 2003 Network Infrastructure

Implementation, Management, and Maintenance Study Guide, Sybex, Alameda CA, 2003, pp. 228, 356-357.

QUESTION 152

If a rogue residential gateway that is running DHCP (Dynamic Host Configuration Protocol) is installed in a network, and the computers in the network have static IP (Internet Protocol) addresses assigned, what problems might occur on the network?

A.There will be no Internet access

B.The computer IP (Internet Protocol) address will change.

C.There should be no problems.

N10-003

D. There will be a routing loop between the residential gateway and the original router.

Answer: A

The network computers have statically assigned IP addresses, the gateway address might not be configured, in which case the network computers might use the rogue gateway and would thus, not be able to connect to the Internet.

Incorrect Answers:

B: The network computers' IP addresses are static addresses and can only be changed manually. The presence of a

rogue residential gateway will not change the static IP addresses.

C: There would be no problems if the gateway address was configured statically on the network computers.

However,

the gateway address is not configured, the network computers might use the rogue gateway and would not be able to

connect to the Internet.

D: A router can update its routing table automatically, to discover which networks are attached to the other routers, or

the routing table can be updated manually by the network administrator. This routing table is used to decide how

packets should be delivered and helps prevent routing loops.

References:

David Groth and Toby Skandier, Network+ Study Guide (4th Edition), Sybex, Alameda CA, 2005, pp. 72-76, 125-127, 145-148.

QUESTION 153

You work as a network administrator at Certkiller .com. You need to reduce the bandwidth used between Certkiller and the Internet. Which of the following could be implemented to accomplish this?

A. WINS (Windows Internet Name Service) server

B. Proxy server

C. DHCP (Dynamic Host Configuration Protocol) server

D. HTTP (Hypertext Transfer Protocol) server

Answer: B

A proxy server handles traffic to the Internet on behalf of the clients on the internal network. It can be configured to

control which the Internet requests can be permitted and which will be denied. This will control which web sites users

can access and which they cannot, reducing Internet bandwidth usage.

Incorrect Answers:

A: A WINS server is used for NetBIOS name resolution in a Windows network.

C: A DHCP server is used to automatically assign TCP/IP configurations to hosts on a network.

D: An HTTP server is a web server that is used to host web sites.

Reference:

David Groth and Toby Skandier, Network+ Study Guide (4th Edition), Sybex, Alameda CA, 2005, pp. 134-13, 142-144.

QUESTION 154

Which of the following could cause a complete network failure on a physical bus network?

- A. One of the networked workstations is powered off.
- B. One of the networked workstations is using the DLC (Data Link Protocol).
- C. A terminator has been removed from the end of the bus trunk cable.
- D. A terminator has been installed on the end of the bus trunk cable.

Answer: C

The two open ends of the bus trunk cable must be terminated to prevent signal bounce. Should the terminator be removed, the entire network will fail. The entire network will also fail if a single connector becomes faulty or a break in the bus trunk cable occurs.

Incorrect Answers:

A: A bus topology has a very low fault tolerance. A failure of any node on the network will bring the entire network

down. However, while a workstation is powered off, its NIC (Network Interface Card) is still functional, and thus the

network is still functional.

B: The bus topology does use data link protocols as it is based at the Data Link Layer of the OSI.

D: The bus trunk cable must be terminated at both ends.

References:

David Groth and Toby Skandier, *Network+ Study Guide* (4th Edition), Sybex, Alameda CA, 2005, pp. 10-11, 12, 52.

David Groth, *Network+ Study Guide* (2nd Edition), Sybex, Alameda CA, 2001, pp. 11-12, 23.

David Groth and Dan Newland, *A+ Complete Study Guide* (2nd Edition), Sybex, Alameda CA, 2001, pp. 313-314.

QUESTION 155

You work as the network administrator at Certkiller .com. The Certkiller network consists of twenty users wired to a switch. The switch is connected to a router for Internet access. A single user reports that she is unable to access the Internet. All other users can access the Internet. Which of the following items should you check to solve the problem?

A. The network card of the problematic machine, the port on the switch that uplinks to router, and the patch cable from

the problematic machine to the switch.

B. The patch cable from the problematic machine to the switch, the port on switch that the problematic machine is

plugged into, and the external interface on the router.

C. The network card of the problematic machine, the port on the switch that the problematic machine is plugged into,

and the patch cable from the problematic machine to the switch.

D. The port on the switch that the problematic machine is plugged into, the network card of the problematic machine,

and the uplink port on the switch.

Answer: C

The problem is affecting only one user. Therefore we should assume that the problem is related a networking

element

from the user's computer to the switch. This could be the NIC on the problem computer, the cable that attached the problem computer to the switch, or the port on the switch to which the problem computer is connected.

Incorrect Answers:

A: The problem is affecting only one user. Therefore we should assume that the problem is related a networking element

from the user's computer to the switch. Anything beyond the switch should not be faulty. The port on the switch that

uplinks to router should also not be faulty as all users would not be able to access the internet if it were faulty.

B: The problem is affecting only one user. Therefore we should assume that the problem is related a networking element

from the user's computer to the switch. Anything beyond the switch should not be faulty. The external interface on the

router should also not be faulty as all users would not be able to access the internet if it were faulty.

D: The problem is affecting only one user. Therefore we should assume that the problem is related a networking element

from the user's computer to the switch. Anything beyond the switch should not be faulty. The uplink port on the switch

should also not be faulty as all users would not be able to access the internet if it were faulty.

References:

David Groth and Toby Skandier, Network+ Study Guide (4th Edition), Sybex, Alameda CA, 2005, pp. 413-415, 417, 441-442.

QUESTION 156

You work as a network engineer at Certkiller .com. You have six workstations that are numbered 16 and are

installed sequentially in a physical ring topology. Workstation 3 fails. How would you remove Workstation 3 from the network without moving the other workstations?

A. Connect Workstation 2 and Workstation 4 using a barrel connector.

B. Add a 75 ohm terminator to Workstation 2 and Workstation 4.

C. Connect Workstation 2 and Workstation 4 using an RJ45 (Registered Jack) coupler.

D. Add a 50 ohm terminator to Workstation 2 and Workstation 4.

Answer: A

The physical ring topology consists of a closed continuous loop of cable in which each computer is connected to the

computer in front of it and the computer behind it in the ring. Data is transferred in only one direction from one node to

the next by means of a token. Because data can move in only one direction, a failure of a single node can cause disruption to the entire network. Should a failure occur, you can use a barrel connector to bypass the faulty node.

Incorrect Answers:

B, D: The physical ring topology requires a cable in a closed continuous loop to create the ring. This loop does

not have

terminators as terminators would break the loop.

C:RJ-45 connectors are used on Ethernet networks which use twisted pair cables. Token ring networks use BNC connectors and co-axial cable.

References:

David Groth and Toby Skandier, Network+ Study Guide (4th Edition), Sybex, Alameda CA, 2005, pp. 13-14, 17-20, 53.

QUESTION 157

You work as a network engineer at Certkiller .com. Ten workstations numbered 1 through 10 are installed sequentially on a physical bus network. A request was made to separate workstations 1 through 5 and workstation 6 through 10 into two separate networks. You cut the cable between workstations 5 and 6. What else, if anything, must you do to complete the job?

A. ~~Do nothing; the job has been successful~~

B. Install a terminator on the severed end of the bus trunk cable connecting workstations 1 through 5.

C. Install a terminator on the severed end of the bus trunk cable connecting workstations 6 through 10.

D. Install terminators on both severed end of the bus trunk cable.

Answer: D

In a bus topology, the bus trunk cable must be terminated at both ends. Therefore you must install terminators on both

severed end of the bus trunk cable.

References:

David Groth and Toby Skandier, Network+ Study Guide (4th Edition), Sybex, Alameda CA, 2005, pp. 10-11.

QUESTION 158

You work as a network administrator at Certkiller .com. Certkiller .com has a medium-sized network with a mixture of different platform computers. The network contains multiple subnets located across a large geographical area. Over half of the subnets contain a WAP (Wireless Access Point) for Internet access. The users on a particular subnet complain of downtime. Upon further troubleshooting, you notice that each day the downtime lasts approximately an hour around midday. You realize that this period of downtime is affecting wireless users only. You travel to the troubled subnet around midday and connect using a wired workstation, but the wireless laptop will not connect. You notice that the WAP (Wireless Access Point) in use is 802.11g. Which of the following would be an appropriate action to address this problem?

A. Upgrade all affected computers to a uniform platform running in ad-hoc mode

B. Eliminate any sources of RFI (Radio Frequency Interference) around the WAP (Wireless Access Point)

C. During the affected time, connect the WAP (Wireless Access Point) directly into the router

D. Change the WAP (Wireless Access Point) and all affected computers to operate in ad-hoc mode

Answer: B

802.11g uses the 2.4 GHz range which is also used by appliances such as microwaves. The connectivity problem

occurs at around lunch time, which seems to indicate that the increased use of microwaves at around this time is causing

RFI (Radio Frequency Interference). We should thus attempt to eliminate this RFI.

Incorrect Answers:

A, D: In ad hoc

mode, two wireless devices can communicate directly, without the need for a WAP. However, RFI (Radio Frequency Interference) will still affect the devices, making connectivity a problem.

C: Connecting the WAP directly to the router will not overcome the RFI (Radio Frequency Interference) that is affecting the wireless signal.

References:

David Groth and Toby Skandier, Network+ Study Guide (4th Edition), Sybex, Alameda CA, 2005, pp. 251, 252, 255.

QUESTION 159

You work as an administrator at Certkiller .com. Certkiller .com has two 100BASE-TX hubs, Hub A and Hub B.

B. The hubs are connected by a 3 meter (9.84 feet) straight-through patch cable. The hosts on Hub A are unable to communicate with the hosts on Hub B. What can you do to resolve the problem?

- A. Install switches instead of hubs
- B. Update all clients with Hub A as their default gateway
- C. Replace the patch cable that connects Hub A to Hub B with a crossover patch cable
- D. Update clients on Hub A as their default gateway and update clients on Hub B as their default gateway

Answer: C

The Ethernet connections on the two hubs are physically and electronically the same medium-dependent interface crossover (MDI-X) port, therefore, you need a crossover cable to connect the two hubs, and not a straight-through cable.

Incorrect Answers:

A: Switches are intelligent hubs. They perform the same function as hubs but reduce collisions by forwarding packets only to the destination host rather than broadcasting packets to all connected hosts.

B, D: Hubs do not have IP addresses. They connect hosts on a single LAN and thus cannot serve as gateways.

References:

David Groth and Toby Skandier, Network+ Study Guide (4th Edition), Sybex, Alameda CA, 2005, pp. 57, 67-69, 290-292, 436-437.

QUESTION 160

You work as a network technician at Certkiller .com. You are troubleshooting a network problem using a utility to capture network packets. When you review the captured data, you notice that you have only captured broadcast packets and packets from your own computer. Why?

- A. You do not have permission to capture other packets.
- B. You are connected to a switch when trying to capture packets.
- C. The router is blocking the packets to the workstation.
- D. You are using an evaluation copy of the software utility.

Answer: B

QUESTION 161

What happens if the wrong WEP (Wired Equivalent Privacy) key is entered into a wireless device?

- A.The network is accessible, but the data will be garbled.
- B.Data can be sent but not received.
- C.The network is not accessible.
- D.The network is only accessible using the SSID (Service Set Identifier).

Answer: C

WEP requires that both the wireless computer and the WAP (wireless access point) be configured with the same encryption key in order for the two to communicate. If one of the two has the wrong WEP key, communication will not

be possible and the network will not be accessible.

References:

David Groth and Toby Skandier, Network+ Study Guide(4th Edition), Sybex, Alameda CA, 2005, p. 254.

QUESTION 162

A Mac OS X 10.3 Kerberos user experiences an authentication failure when trying to access a kerberized service provided by Mac OS X Server 10.3. Which of the following steps might resolve the issue?

- A.Install Kerberos client software for Mac OS X 10.3 on the user's computer.
- B.Synchronize all Kerberos principal's clocks using a network time server.
- C.Ensure that the IP address of the user's computer to allow the user to access the service.
- D.All of the above.

Answer: B

QUESTION 163

You work as a web master at Certkiller .com. The Certkiller .com website is hosted on a Linux machine. Users complain that they receive a forbidden error message when visiting the Certkiller .com web site. You log onto the Linux server and changes to the directory where the web site pages are stored. What should you do NEXT?

- A.Rename the webpage files
- B.Change the symbolic link
- C.Change the web port to 8080 on the client
- D.Change the permissions of the directory

Answer: D

Incorrect Answers:

A:Forbidden error messages are received when a client doesn't have permissions to access a web page.

Renaming the

web page will not change the permissions on them.

B:The symbolic link indicates whether the connection is secure or not. It will not prevent a web page from opening.

C:HTTP uses TCP port 80. Changing to port 8080 will prevent the client from accessing any web site.

QUESTION 164

You work as a network technician at Certkiller .com. There are three identical desktop computers on the

N10-003

Certkiller .com network. However, one of the computers cannot connect to the other computers. You check the network interface card in the problematic computer and find that neither the link light nor the activity light is illuminated. You swap the network cable with a cable that is known to be operational, but the lights still do not illuminate on the NIC or the corresponding port on the switch. What would be your next troubleshooting step?

- A.Switch to a crossover cable.
- B.Reinstall the NIC.
- C.Change ports on the switch.
- D.Enter the correct TCP/IP settings.

Answer: C

Incorrect Answers:

A:A crossover cable is used if the two ports or interfaces are physically and electronically the same. However, we are checking connectivity between a workstation and a switch. The NIC on the workstation has a medium dependent interface (MDI) port while the switch has a medium dependent interface-crossover (MDI-X) port. Therefore, we would use a straight-through cable and not a crossover cable to connect the two.

B:The first step in troubleshooting is always to isolate the problem. Thus far we have verified that the cable is not the problem. The next logical step would be to check the port on the switch by connecting the cable to a different port. If that does not resolve the problem then we can rightfully suspect that the problem lies with the NIC.

D:The LED lights on the NIC and on the corresponding port on the switch are illuminated when there is physical connectivity between the NIC and the switch. This connectivity is not dependent on the TCP/IP setting on the computer.

References:

David Groth and Toby Skandier,Network+ Study Guide(4th Edition), Sybex,AlamedaCA, 2005, pp. 290-292, 415-416,436-437.

QUESTION 165

In the following exhibit, identify the network topology in use.

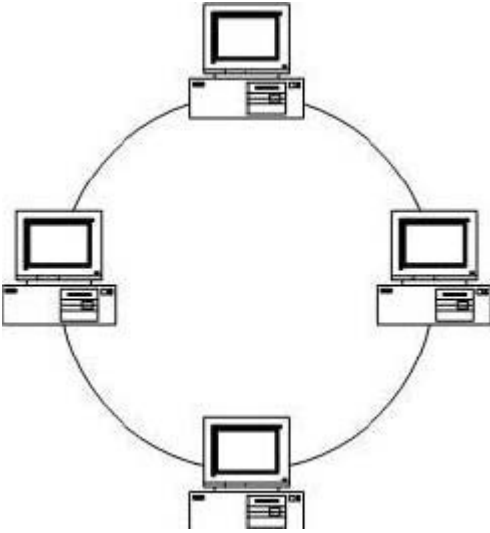

- A. A bus topology.
- B. A ring topology.
- C. A star topology.
- D. A mesh topology.

Answer: B

In a ring topology the clients are connected to each other to form a closed loop.

QUESTION 166

Which networking topology is capable of connecting computers along a single linear segment?

- A. A bus topology
- B. A ring topology
- C. A star topology
- D. A mesh topology

Answer: A

Explanation: A bus topology connects computers along a single linear segment.

Incorrect Answers

B: A ring topology arranges the computers in a ring.

C: A star topology has a central hub (or switch) and each computer is directly connected to this hub.

D: In a mesh topology all devices are directly connected.

QUESTION 167

The Certkiller trainee technician wants to know which two network technologies makes use of the same media access

method. What will your reply be? (Choose two)

- A. Token Ring
- B. Ethernet
- C. AppleTalk
- D. FDDI

Answer: A, D

Explanation: Both FDDI and Token Ring use a token that travels around a ring.

Incorrect Answers

B:Ethernet use the CSMA/CD access technology.

C:AppleTalk is a protocol not a network technology.

QUESTION 168

Which topology should you recommend in a scenario where your company is planning to rebuild its network infrastructure and you are requested to provide a topology that will be both scalable and easy to troubleshoot?

A.A bus topology

B.A ring topology

C.A star topology

D.A mesh topology

Answer: C

Explanation: A star topology is easy to expand and easy to troubleshoot as well.

Note:One drawback with the star topology is the amount of cabling that must be used.

Incorrect Answers

A:A bus topology does not scale well. It might also be difficult to find troubleshoot a failed bus segment.

B:A ring network does not scale very well.

D:In a mesh topology all network devices are interconnected which it quite unscalable.

QUESTION 169

IEEE 802.5 maps to which of the following?

A.Voice data transmissions

B.Token bus

C.Ethernet

D.Token Ring

Answer: D

Explanation: The IEEE 802.5 standard defines token ring.

Incorrect Answers

A:Voice data transmissions does not map directly to any IEEE 802.x standard.

B:Token bus is defined in IEEE 802.4.

C:The IEEE 802.3 standard defines Ethernet.

QUESTION 170

What term is used to refer to the physical layout of components on a network?

A.backbone

B.protocol

C.segment

D.topology

Answer: D

Explanation: The topology is the pattern used to connect the computers together.

Incorrect Answers

A:The backbone is the highspeed connections that connect different LANs.

B:Networked computers use protocols to communicate.

C:A segment is only one part of the network.

QUESTION 171

The new Certkiller trainee technician wants to know which of the following network topologies is the most faulttolerant and has the most redundancy. What will your reply be?

A.BUS

B.RING

C.STAR

D.MESH

E.None of the above

Answer: D

Explanation: In a meshed topology every device is directly connected to all other devices.

Incorrect Answers

A:A bus is a single network segment. If this segment breaks the whole network stops to function.

B:If a single link in a ring network fails, the whole ring fails.

C:The central hub in a star topology is a single point of failure.

QUESTION 172

In the following exhibit, identify the network topology in use.

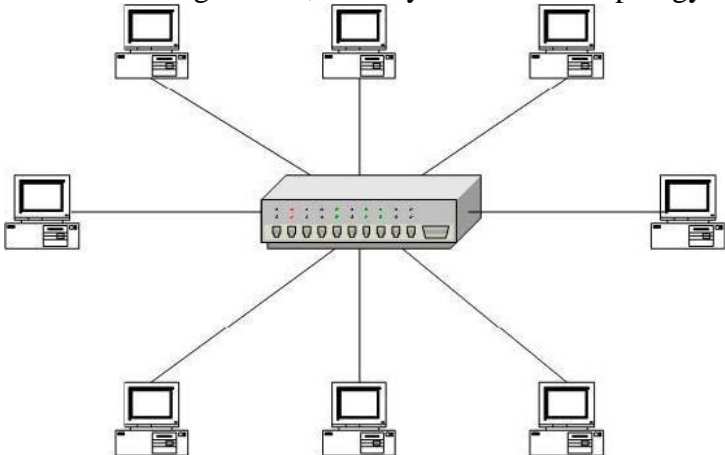

A.A bus topology.

B.A ring topology.

C.A star topology.

D.A mesh topology.

Answer: C

In a star topology the clients are connected to a hub.

QUESTION 173

You are building a small home network. You want to use a network topology that requires the least hardware and cabling. What topology will you use?

- A.A bus topology.
- B.A ring topology.
- C.A star topology.
- D.A mesh topology.

Answer: A

A bus network requires only a single cable trunk.

QUESTION 174

You are building a small home network. You want to use a network topology that is the easiest to reconfigure. What topology will you use?

- A.A bus topology.
- B.A ring topology.
- C.A star topology.
- D.A mesh topology.

Answer: C

A star topology requires virtually no reconfiguration.

QUESTION 175

To which of the following does a patch cable connect to in a token ring network?

- A.A workstation to a router
- B.Two workstations
- C.Two MAU's together

Answer: C

Explanation: MAUs are hubs in a token ring network. Two MAUs are interconnected with a patch cable.

Incorrect Answers

A:In a token ring environment a workstation would not be directly connected to a router.

B:Two workstations are connected with a standard STP/UTP cable.

QUESTION 176

You are building a small home network. You want to use a network topology that connects computers via multiple paths. What topology will you use?

- A.A bus topology.
- B.A ring topology.
- C.A star topology.
- D.A mesh topology.

Answer: D

In a mesh topology every node is connected to three or more other nodes.

QUESTION 177

Users on the token ring network segment are experiencing slow response time. What could be the cause of this problem?

- A. The network segment is open.
- B. The network is experiencing late collisions due to cable length.
- C. The network token passing is delayed due to large file transfers.
- D. The network is experiencing early collisions due to cable length.

Answer: C

Large file transfers could slow down the traffic on a token ring network. A token ring segment that has an open segment would not function at all. There are no collisions on token ring networks. Data is transferred in a token.

QUESTION 178

You are the network administrator at your company. The company has its headquarters in New York and a small branch office in Salem. The Salem office has a token ring network that is connected to the head office via WAN links.

The company's network is shown in the following exhibit

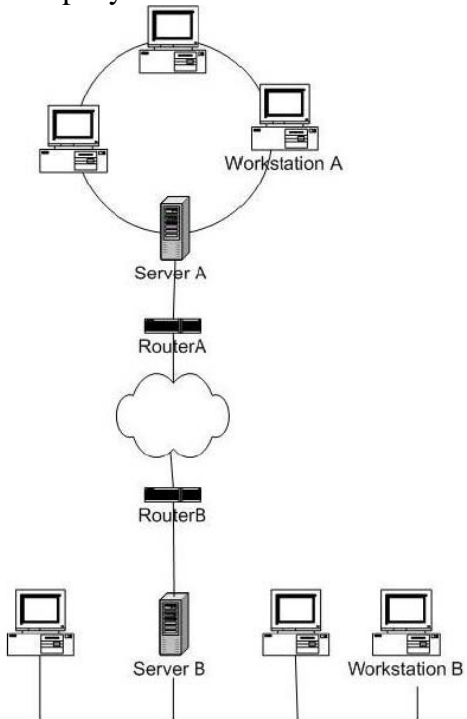

The user of Workstation B complains that he cannot retrieve files from Server B. However, Workstation A is able to retrieve files from Server B.

What is the most likely cause of this problem?

- A. Bus failure
- B. Router B failure

- C.Token Ring failure
- D.Incorrect gateway on Workstation B

Answer: A

The failure must be between Workstation B and Server B. A possible source of the failure is the bus network (or the patch cables, or the NIC of the workstation).

QUESTION 179

You are the network administrator for your company. The company has a large multiring network. At 11 P.M. a user

complains that she can no longer communicate on the network. She could earlier.

What should be your first step in troubleshooting this problem?

- A.Isolate the ring
- B.Restore the ring
- C.Isolate the client machine
- D.Remove the failing section
- E.Repair the defective component

Answer: A

First we should isolate the ring and troubleshoot it locally.

QUESTION 180

You are researching network topologies. In which IEEE specification will you find the specifications for a logical ring topology?

- A.802.3
- B.802.5
- C.802.12
- D.802.11a

Answer: B

The 802.5 standard defines a Token ring network.

QUESTION 181

You are designing a mission critical network. You want to ensure that no network node is compromised by a single link failure. Which networking topology should you use?

- A.bus
- B.star
- C.ring
- D.mesh

Answer: D

In a mesh topology each device is connected to at least three other devices.

QUESTION 182

Which of the following media access methods is used for an IEEE 802.5 network?

- A.Polling
- B.Token passing.
- C.Demand priority.
- D.Carrier sense multiple access/collision detection.
- E.Carrier sense multiple access/collision avoidance.

Answer: B

Explanation: The 802.5 standard defines a Token ring network. Token Ring networks use Token passing.

QUESTION 183

Which of the following access methods does Gigabit Ethernet make use of?

- A.ATM
- B.CSMA/CD
- C.Frame Relay
- D.Token passing

Answer: B

Explanation: Ethernet, including Gigabit Ethernet, use the CSMA/CD (Carrier Sense Multiple Access with Collision Detection) access method.

Incorrect Answers

- A, C: ATM and Frame Relay are used for WAN connections, not for Ethernet networks.
 - D: Token ring and FDDI used token passing.
-

QUESTION 184

Standards for CSMA/CD specified by which IEEE 802.x sublayer?

- A.802.1
- B.802.2
- C.802.3
- D.802.4
- E.802.5

Answer: C

Explanation: IEEE 802.3 defines Carrier Sense Multiple Access with Collision Detection (CSMA/CD) Access Method and Physical Layer Specifications.

Incorrect Answers

- A: 802.1 is oriented towards WAN connections.
 - B: 802.2 defines the Logical Link Control. It is used both by 802.3 and 802.5.
 - D: 802.4 describes the token bus standard, not a popular implementation.
 - E: The 802.5 standard defines a Token ring network.
-

QUESTION 185

What connector is used to connect an external transceiver to a NIC?

[N10-003](#)

- A.ST
- B.SC
- C.AUI
- D.BNC
- E.RJ45

Answer: C

An AUI connector connects the clients via an external transceiver to a Thicknet coaxial cable.

QUESTION 186

What connector would you use in a 10BASE2 environment?

- A.STP
- B.BNC
- C.RJ11
- D.RJ45

Answer: B

10Base2 networks uses Thinnet coaxial cables. BNC connectors are used to connect clients to a Thinnet coaxial cable.

QUESTION 187

Which IEEE standard describes the Physical layer for a token ring network?

- A.802.1
- B.802.2
- C.802.3
- D.802.4
- E.802.5

Answer: E

802.5 is the Standard for Token ring networks.

QUESTION 188

Which of the following cable types is most susceptible to crosstalk?

- A.UTP
- B.STP
- C.coaxial
- D.fiber optic

Answer: A

Unshielded twisted pair cables are most crosstalk susceptible.

QUESTION 189

You are the network technician at your company. You are in the process of upgrading the company's

10BaseT
network to a 100BaseT

N10-003

network. You have replaced the 10BaseT switch with a 100BaseT switch. You tell your assistant to install the patch cables to connect the workstations to the switch. What patch cables should your assistant use?

- A.RG-58 Coax
- B.RG-62 Coax
- C.Category 3 UTP
- D.Category 5 UTP

Answer: D
Category 5-UTP cables are used in a 100Base-T network.

QUESTION 190

You are the network technician at your company. You are in the process of upgrading the company's 10Base-T network to a 100Base-T network. You have replaced the NICs in the workstations and servers. You have also replaced the 10Base-T switch with a 100Base-T switch. You tell your assistant to install the patch cables. What patch cables should your assistant use?

- A.RG-58 Coax
- B.RG-62 Coax
- C.Category 3 UTP
- D.Category 5 UTP

Answer: D
100Base-T networks require Category 5 UTP cabling.

QUESTION 191

You are the IT supervisor at your company. A network technician is unsure of where to use a 1000BaseCX patch cable. What should you advise her?

- A.1000Base-CX patch cable has a maximum length of 3 kilometers and is usually used for fibre optic connections between nodes.
- B.1000Base-CX patch cable has a maximum length of 25 meters and is usually used for short-haul copper connections within wiring closets.
- C.1000Base-CX patch cable has a maximum length of 100 meters and is usually used for copper connections between workstations and the wiring closet.
- D.1000Base-CX patch cable has a maximum length of 550 meters and is usually used for fibre optic connections between workstations and the wiring closet.

Answer: B
1000BASE-CX is intended for short-haul copper connections (25 meters or less) within wiring closets.

QUESTION 192

You are the network technician at your company. Your company has a 10Base-T network. You want to

N10-003

improve network response time and decide to upgrade the network to 100Base-TX. You replace the company's 10Base-T switch with a new 100Base-TX switch. The NIC in the workstations are auto-negotiating 10/100 cards that do not require replacement.

After you install the new switch, you discover that no workstation can communicate on the network.

However, your laptop that you use for troubleshooting purposes works perfectly when plugged directly into a port on the 100Base-TX switch.

You remove the 100Base-TX switch and reinstall the old 10Base-T switch. The workstations can now communicate on the network again. What is the problem with the 100Base-TX switch?

- A. The company is using Category 5 cabling
- B. The company is using 10-foot patch cables.
- C. The company is using Category 3 patch cables.
- D. The total segment length to the workstations from the switch is less than 300 feet.

Answer: C

Category 3 patch cables only supports speeds of 10Mbps not 100Mbps.

Category 5 cabling is required, there is no problem with 10-foot patch cables, and the maximum segment length in a

100Base TX network is 100 meters (330 feet).

QUESTION 193

You are installing a NIC for 10Base-T network. On the exhibit below, click the 10Base-T NIC.

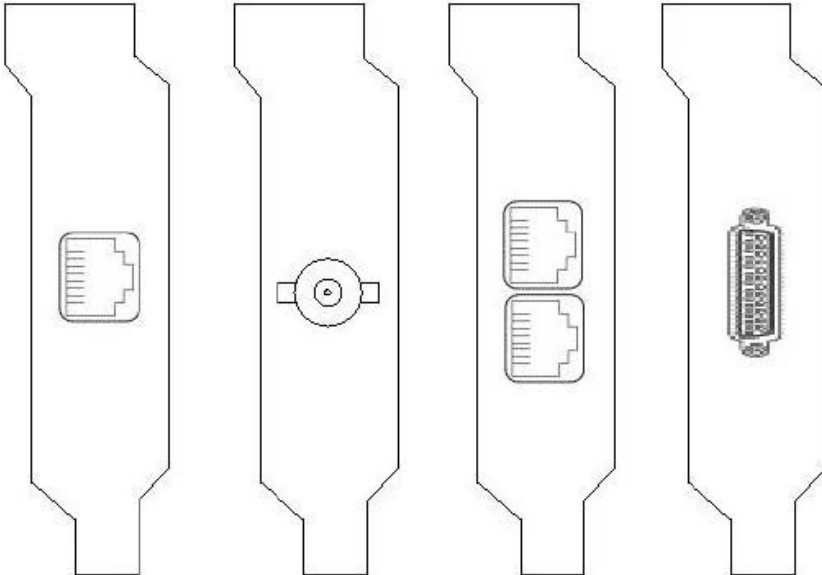

Answer:

N10-003

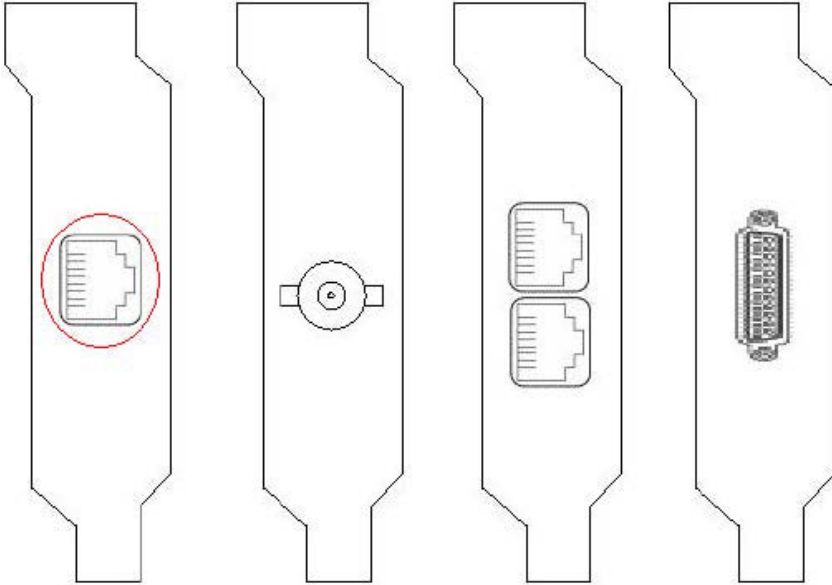

Explanation:

A 10Base-T network use CAT 5 cabling and RJ-45 connectors.

The NIC with the BNC connector is used for 10Base2 networks.

The card with two RJ-11 connectors is a modem card with a line in and line out for a standard telephone connector.

The AUI connector is used for 10Base5 networks.

QUESTION 194

You are the IT supervisor at a large company. A trainee network technician is replacing a 100Base-T switch with a 100Base-FX switch. He informs you that the media connectors do not fit. Which media connectors should he use?

- A.coaxial
- B.fiber optic
- C.Category 2 UTP
- D.Category 5 UTP

Answer: B

A 100Base-FX network uses fiber optic cabling.

QUESTION 195

You are building a large network. You want to avoid the problems of cross-talk. What cable types should you use?

- A.UTP
- B.STP
- C.coaxial
- D.fiber optic

Answer: D

There is never any cross-talk in fiber optic cables.

QUESTION 196

You are a network technician. A customer comes to you with a fiber connector that uses a twisttype attachment mechanism. He asks you to identify the connector. What would you tell the customer?

- A.It is a FC connector
- B.It is a ST connector
- C.It is a SC connector
- D.It is a MT-RJ connector

Answer: B

An ST (twist-on) connector uses atwist-type attachment mechanism.

QUESTION 197

You are building a network using 10 Mbps Ethernet adapters. Client machines are located at a maximum distance of

150 meters from the hub. What network transmission medium can you use to connect the client machines to the hub?

- A.10Base2
- B.10Base5
- C.100Base-T
- D.100Base-LX

Answer: A

10Base2 has a maximum speed of 10Mbps and a maximum distance of 185 meters, while 10Base5 has a maximum

distance of 500 meters.

100Base-T has a maximum distance of 100 meters. There is no 100Base-LX medium.

QUESTION 198

You are building a small home network that will use vampire taps. Which transmission medium would you require to connect the clients?

- A.UTP
- B.STP
- C.coaxial cable
- D.fiber optic cable

Answer: C

Vampire taps are used to connect clients to Thicknet coaxial cables.

QUESTION 199

You are building a 10Base2 network. What media will you use?

- A.UTP cable with RJ-45 connectors
- B.UTP cable with RJ-11 connectors
- C.STP cable with RJ-45 connectors
- D.RG-58 cable with T-connectors

[N10-003](#)

Answer: D

10Base2 network use Thinnet coaxial cables (RG-58 cable), T-connectors and BNC Terminators.

QUESTION 200

Task: Click the BNC Connector



Answer:



Explanation:

The upper connector is a BNC connector and the lower connector is a RJ-45 connector.

QUESTION 201

You are installing a 1000Base-T NIC in Workstation. What is the maximum segment length of a 1000Base-T segment?

- A. 100 meters
- B. 325 meters
- C. 550 meters
- D. 3 kilometers

Answer: A

Like 10Base-T and 100Base-T, the maximum distance of a 1000Base-T segment is 100 meters.

QUESTION 202

How many pair of wires does a 10Base-T cable use?

- A.one
- B.two
- C.three
- D.four

Answer: B

A 10Base-T cable use two pair of wires.

QUESTION 203

You are building an Ethernet network. Each node is approximately 150 meters from the hub. Which network transmission medium cannot be used in this network?

- A.10Base2
- B.10Base5
- C.10Base-T
- D.10Base-FX

Answer: D

10Base-T networks have a maximum speed of 10Mbps and maximum distance of 100 meters.

10Base2 networks have a maximum distance of 185 meters.

10Base5 networks have a maximum distance of 500 meters.

10Base-FX networks have a maximum distance of 3 kilometers.

QUESTION 204

You are a network administrator at your company. The company is adding a new department to its 100BASE-TX network. You place a switch in the wiring closet for the new department and plug a certified drop from the router into the switch. You also use certified premise wiring connected into the switch for connection to the wall outlets. All workstations connected to the wall outlets are identical. Later, some users complain that they their workstations do not function properly however, other workstations do function properly.

What is the most likely cause of this problem?

- A.You used Category 5 cables.
- B.The jacks used for the wall outlets are RJ-45.
- C.The patch cables are only using two pairs.
- D.The lengths of the premise wiring cables are shorter than 100 meters.

Answer: C

A possible cause of the problem could defective patch cables.

QUESTION 205

Due to employee complaints of high temperatures in the office, Certkiller Inc. recently installed a number of fans.

However, users complain of slow LAN and WAN activity. In your troubleshooting activity you ascertained that nothing on the UTP CAT5 network has changed to cause this.

N10-003

What do you think is responsible for the slow activity?

- A.AMI
- B.EMI
- C.MIB
- D.DMI

Answer: B

Explanation: Unshielded twisted-pair (UTP) cabling is effected by electromagnetic interference (EMI). Real-life sources of EMI are high frequency transceivers, electric motors (used for fans for example), and common fluorescent light fixtures.

QUESTION 206

What amount of wire pairs is used in a 100Base-T4 cable?

- A.One
- B.Two
- C.Three
- D.Four

Answer: D

Explanation: A 100Base-T4 cable normally has four pairs of wire.

QUESTION 207

Which of the following connectors connects a v.90 modem to the telephone network?

- A.ST
- B.SC
- C.BNC
- D.RJ-11
- E.RJ-45

Answer: D

Explanation:

V.90 modems are analog and use the telephone line. RJ-11 is a standard telephone connector.

Incorrect Answers

A, B:SC and ST connectors are used for fibre optic cabling.

C:BNC is used in coaxial cable networks.

E:RJ-45 connectors are used for UTP and STP cabling.

QUESTION 208

Which hardware device is capable of creating an electrical signal on a wire so it can be located by a technician in the wiring closet?

- A.Tone locator

[N10-003](#)

- B. Tone generator
- C. Crossover cable
- D. Hardware locator

Answer: B

Explanation: The tone generator is a device that you connect to a cable at one end, and which transmits a signal over the cable.

Incorrect Answers

A: The tone locator is a separate device that has a probe capable of detecting the tone generator's signal, either by

touching it to the conductor in the cable, or simply by touching it to the insulation on the outside of the cable.

C: A crossover cable connects two similar networked devices such as two PCs or two hubs.

D: There is no such thing as a hardware locator.

QUESTION 209

Task

Click the RJ-45 Connector



Answer:

N10-003

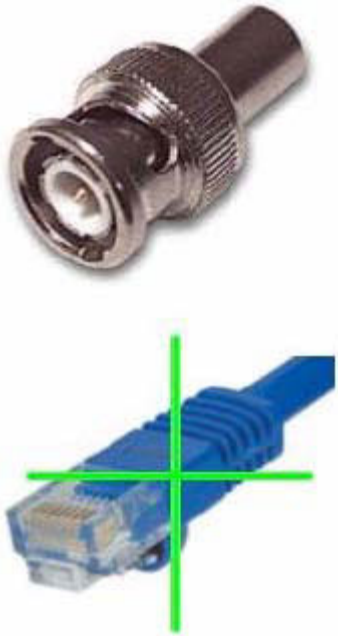

Explanation:

The upper connector is a BNC connector while the lower connector is a RJ-45 connector.

QUESTION 210

You are installing a NIC for 10Base2 network. On the exhibit below, click the 10Base2 NIC.

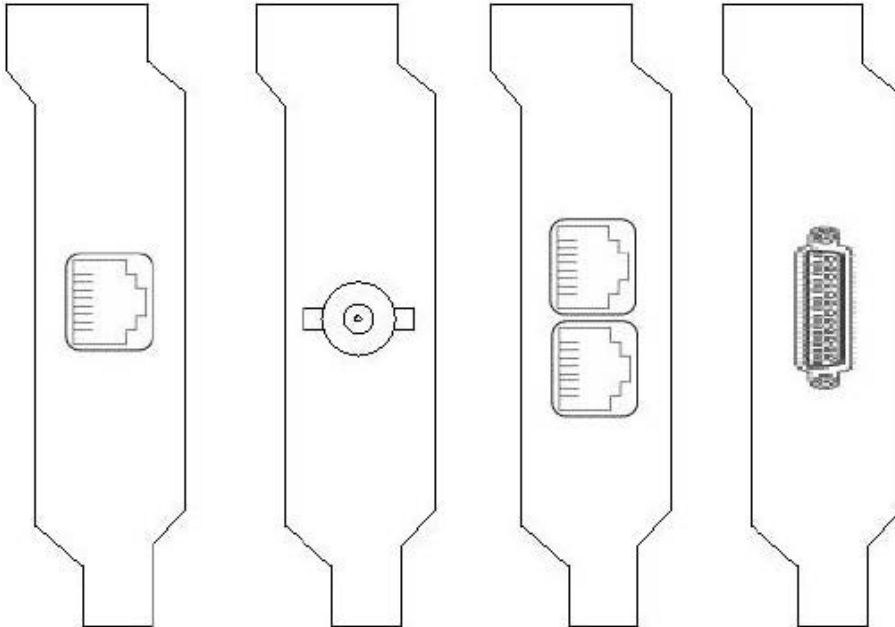

Answer:

N10-003

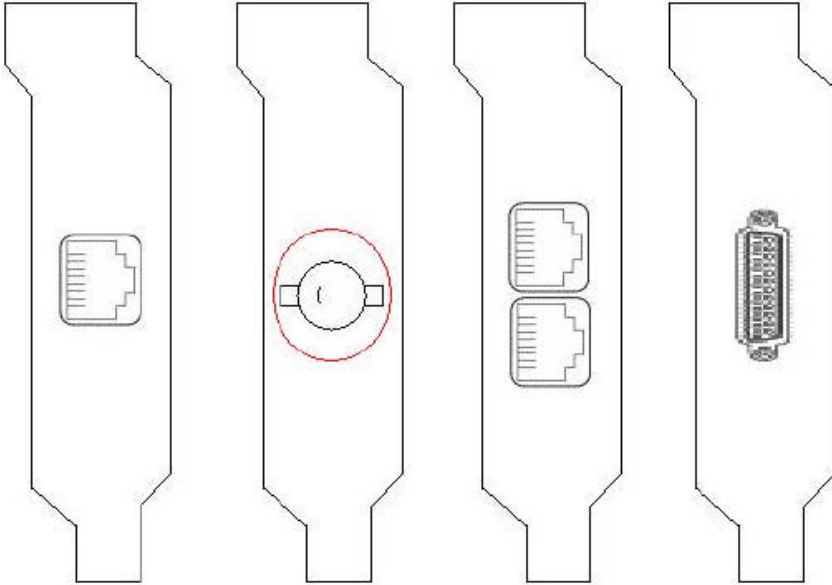

Explanation:

A 10Base-T network use CAT 5 cabling and RJ-45 connectors.

The NIC with the BNC connector is used for 10Base2 networks.

The card with two RJ-11 connectors is a modem card with a line in and line out for a standard telephone connector.

The AUI connector is used for 10Base5 networks.

QUESTION 211

On the following exhibit, click the coaxial port.

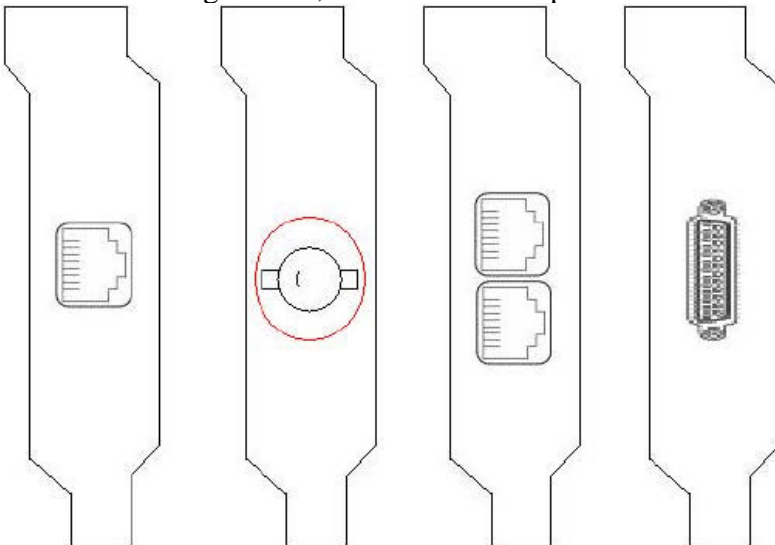

Answer:



N10-003

Explanation:

Don't select the AUI port to the left or the fiber optic port to the right.

QUESTION 212

The Certkiller trainee technician wants to know what the maximum length of a Gigabit Ethernet segment using multimode fiber optic cable is. What will your reply be?

- A.100 meters
- B.325 meters
- C.550 meters
- D.3 kilometers

Answer: C

Explanation: Gigabit Ethernet support distances of 550m for multimode fiber links.

Single mode fiber supports distances of 5 kilometers.

Incorrect Answers

Gigabit Ethernet using Category 5 UTP has the maximum distance of 100 meters.

QUESTION 213

A user wants to place a 10BASE-T network printer at a location in the warehouse. The printer is installed in the warehouse and is connected to the 10BASE-T hub in a nearby administration building. However, the printer is not functional.

What is cause of the problem?

- A.The cabling used is not Category 5.
- B.The 10BASE-T hub uses RJ-45 connectors.
- C.The length of the cable is greater then 100 meters.
- D.The printer uses an AUI connector to connect to its 10BASE-T transceiver.

Answer: C

Explanation: The maximum cable distance is 100 meters in a 10BaseT network. A greater distance could cause inoperability.

Incorrect Answers

A:Only Category 5 is required in a 10BaseT network.

B:A 10Base T network printer use UTP/STP cabling and has a RJ45 connector, just as a 10Base T hub.

D:AUI connectors is only used in 10Base5 network, not in 10BaseT network

QUESTION 214

Which of the following connectors can be used in conjunction with fiber optic cabling? (Choose two)

- A.SC
- B.ST
- C.AUI

- D.BNC
- E.RJ-11
- F.RJ-45

Answer: A, B

Explanation:

A:An SC connector is a pushstyle connector that uses fiber.

B:The ST connector is used for fiber optic.

Incorrect Answers

C:AUI is used for 10Base5.

D:BNC is used for 10Base2.

E:RJ-11 is for the phone socket.

F:RJ-45 is for UTP and STP cabling.

QUESTION 215

What can you tell the Certkiller trainee technician is the maximum length of a 100Base-T Ethernet UTP segment?

- A.100 meters
- B.325 meters
- C.185 meters
- D.550 meters

Answer: A

Explanation: The maximum length of an UTP segment is 100 meters.

QUESTION 216

Which medium can you use to connect a Small OfficeHome Office (SOHO) computer to an external DSL modem?

- A.RG-58 coaxial
- B.Category 5 UTP
- C.Single-Mode Fiver Optic
- D.RS-232 serial cable

Answer: B

Explanation: The computer is connected to the DSL modem with a standard Category 5 UTP cable.

QUESTION 217

Which of the following statements most aptly describes an SC connector?

- A.A BNC-style connector that uses fiber.
- B.A push-style connector that uses fiber.
- C.A six-position connector that uses UTP.
- D.An eight-position connector that uses UTP.

Answer: B

Explanation: An SC connector is a push-style connector that uses fiber.

Incorrect Answers

A: BNC cabling is used with coaxial cable, not for fiber cabling.

C, D: A SC connector is used for fiber, not with UTP.

QUESTION 218

Which line would you recommend to a customer in need of 1.5 megabits per second (Mbps) connection to the Internet?

A. T1

B. DS0

C. 56 Kbps

D. BRI ISDN

Answer: A

Explanation: T1 provides 1.544 Mbps.

Incorrect Answers

B: DS0 only provides 64Kbps.

C: We need 1.5Mbps, which is 27 times faster than 56Kbps.

D: BRI ISDN only provides 128Kbps.

QUESTION 219

Study the Exhibit below carefully:

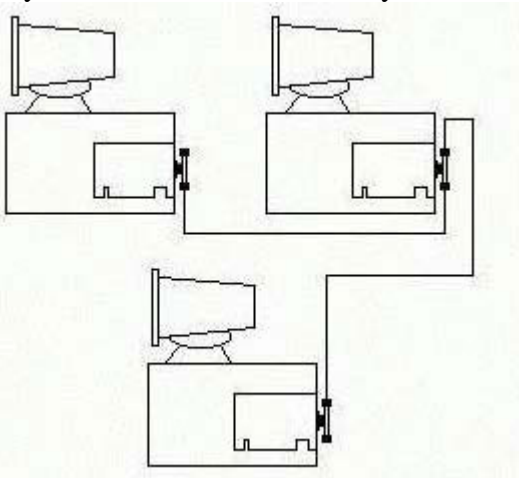

Users on the network are complaining of slow performance on the network as shown in the exhibit. There are also high

occurrences of collisions. What can be the cause of the problem?

A. Category 3 cabling is used.

B. There is a loose 50 ohm terminator.

C. Multimode fiber is used instead of Single-Mode fiber.

D. A BNC T connector is disconnected from a machine but both cables are still connected to the BNC T.

N10-003

Answer: B

Explanation:

networks must be terminated with 50 ohm terminators at each end. A loose 50 ohm terminator would result in bouncing signals which would slow down the network due to high occurrence of collisions.

Incorrect Answers

A:Category 3 cabling is used in a star topology, not in a bus topology.

C:Fiber cabling cannot be used in a bus topology 10Base2 network.

D:A disconnected T connector in a 10Base2 network would stop all traffic on the network.

QUESTION 220

For a connection over a distance of more than 1 km, which Ethernet implementation would you use?

A.10Base2

B.10Base5

C.10BaseT

D.10BaseFX

Answer: D

Explanation: Fiber must be used for connections over 1000 meters in length. 10BaseFX use fiber.

Incorrect Answers

A:10Base2 has a maximum connection distance of 185 meters.

B:10Base5 has a maximum connection distance of 500 meters.

C:10BaseT has a maximum connection distance of 100 meters.

QUESTION 221

Which 100 Mbps networking standard makes use of only two pairs of a Category 5 UTP cable?

A.10BaseT

B.100BaseT4

C.100BaseTX

D.100BaseVG

Answer: C

Explanation: 100BaseTX uses two UTP pairs (four wires) in a Category 5 UTP cable

Incorrect Answers

A:10BaseT requires Category 3 UTP.

B:100BaseT4 requires Category 3 UTP.

D:100BaseVG requires Category 3 unshielded twisted pair (UTP) cable

QUESTION 222

Which of the following IEEE specifications does CSMA/CD map to?

A.802.2

B.802.4

N10-003

- C.802.3
- D.802.6

Answer: C

Explanation: CSMA/CD is better known as Ethernet. Ethernet is defined in the IEEE 802.3 standard.

Incorrect Answers

- A:802.2definesLogical Link Control. It is used both by 802.3 and 802.5.
- B:802.4describesthe token bus standard, not a popular implementation.
- D:802.6definesa MAN (Metropolitan Area Network) standard.

QUESTION 223

Which of the following are the most common IEEE standards? (Choose three)

- A.802.3
- B.802.4
- C.802.2
- D.802.5

Answer: A, C, D

Explanation:

- A:802.3 is the Ethernet standard. It is the most common IEEE standard.
- C:802.2definesLogical Link Control. It is used both by 802.3 and 802.5.
- D:802.5 defines token ring.

Incorrect Answers

- B:802.4describesthe token bus standard, not a popular implementation.

QUESTION 224

Which of the following is capable of converting media types?

- A.Transceiver
- B.Hub
- C.Switching Hub
- D.Gateway
- E.All of the above

Answer: D

QUESTION 225

You are the network technician at your company. You move a workstation from the Sales Department to a new office. The workstation has a 10BaseT NIC to connect to the network. You would like to improve a faster connection for the workstation and easier access for the user. The workstation is 10 meters from the wall plug. The wall plug is another 90 meters from the wiring closet. The wiring closet is 3 meters from the hub. After connecting the patch cable, you discover that you cannot connect to the network.

You consider replacing the NIC with a 100baseTX

NIC. What would this accomplish?

- A.This will meet the objective of connecting to the network. It does not provide a faster connection for the

N10-003

workstation

and easier access for the user.

B.This will only meet the objective of a faster connection for the workstation and easier access for the user.

C.This will meet the objective of connecting to the network. It will also provide a faster connection for the workstation

and easier access for the user.

D.This will not meet the objective of connecting to the network. Nor will it provide a faster connection for the workstation or easier access for the user.

Answer: D

Explanation: The first problem is that UTP that is used in a 10BaseT network has a maximum distance of 100 meters.

Currently there are 103 meters between your computer and the hub. This is not fixed by changing the NIC of your

computer. Thus network connectivity is not accomplished.

Furthermore, just using a faster NIC would not improve speeds as long as 10BaseT cabling still is in use or easier

access for the users.

QUESTION 226

You are a network technician at your company. A network user complains that when he turns the lights on in the office,

he cannot connect to the network. With the light off, he can access the network.

What could be the cause of this problem?

A.There is a voltage drop when the lights are turned on.

B.The NIC needs to be replaced.

C.The cabling system is faulty.

D.All of the above.

Answer: C

Explanation: There is a cabling problem. There is interference between the network cabling and the power cabling.

Incorrect Answers

A:The problem is constant when the lights are on, not just when the lights are turned on.

B:The NIC works fine when the lights are off.

D:A) and B) are false.

QUESTION 227

You are the network administrator at your company. Your company is moving into a new building.The building has

network jacks labeled 10BaseT jacks for the workstation.However, when you connect a workstation to a jack and

plug the patch cable from the patch panel to the hub, you do not get a link light on the NIC or the hub.You have tried to

N10-003

replace both patch cables with known, good patch cables. It still does not work.
What should you do next?

- A. Hook a protocol analyzer to the hub.
- B. Reinstall the network interface card driver.
- C. Test the cable from wall jack to patch panel.
- D. Replace the workstation patch cable with a crossover cable.

Answer: C

Explanation: We should analyze the cable. It could be the cause of the problem.

Incorrect Answers

A: It seems likely that this is a physical problem, not a network configuration problem.

B: It seems likely that this is a physical problem, not a driver problem.

D: A crossover cable should not be used between the PC and the wall jacket. Crossover cables are used to connect

two similar devices, for example two hubs, or two PCs.

QUESTION 228

You want to implement a Gigabit Ethernet system. Which connectors could you use in such a network? (Choose all that apply.)

- A. ST
- B. SC
- C. AUI
- D. BNC
- E. RJ-45

Answer: B, E

Gigabit Ethernet standards are defined by 1000BASE-xx for fiber and shielded copper cabling. 1000Base-xx is defined

in 802.3z and includes the following three standards:

1. 1000BASE-SX defines operation with short (850nm) wavelength lasers using a dual SC connector.
2. 1000BASE-LX defines operation with long (1300nm) wavelength lasers using a dual SC connector.
3. 1000BASE-CX defines operation with 150-Ohm shielded balanced copper cables up to 25m (jumper cables). 1000Base-CX use over shielded twisted pair cabling and RJ-45 connections.

QUESTION 229

On the following exhibit, click the AUI port.



Answer:

N10-003



Explanation:

Don't select the coaxial port in the middle or the fiber optic to the right.

QUESTION 230

In the following exhibit, click the fiber optic port.



Answer:



Explanation:

Don't select the AUI port (to the left), or the coaxial port in the middle.

Category 5 cables and RJ-45 outlets should be used. Length up to 100 meters are supported in a 100BASE-TX network.

QUESTION 231

You are a network Technician at your company. You install a 10BaseT NIC into a Windows 95 workstation.

You are

now busy configuring it on an Ethernet network. You configure the IRQ and I/O base address for the NIC.

What else

must you do for the NIC to operate successfully on the network?

- A. Install network client software.
- B. Connect the cable to the MAU.
- C. Connect the cable to the network card.
- D. Install the terminator at the network card.

Answer: A, C

Explanation:

A: We need to install network client software, such as network drivers and network protocols.

C: We must physically connect the workstation to the network through the network card.

Incorrect Answers

B: MAU are specialized hubs used only in token ring network. There is no general requirement to connect a workstation to a MAU.

N10-003

D:Terminators are only used on Coaxial cable networks such as 10Base2 (Thinnet) and 10Base5 (Thicknet). However, this workstation uses a 10-BaseT NIC so it cannot be connected to these networks.

QUESTION 232

You are the supervisor of the IT Department at your company. A technician added a MAU and workstations to the Marketing Department. However, employees in the Marketing Department that are connected to the new MAU can communicate with each other but not with users on the original MAU. How should the technician resolve this problem?

- A.Set the new MAU to full duplex.
- B.Connect the uplink ports to each other on the MAU.
- C.Connect the ring in port to the ring out port on each MAU.
- D.Connect the ring in port to the ring in port and ring out port to ring out port in each MAU.

Answer: C

The ring in port of one MAU should be connected to the ring out port of the other MAU.

QUESTION 233

You are the supervisor of the IT Department at your company. Because of network growth, you instructed a technician to add a new MAU to the network. However, users connected to the new MAU are not able to connect to the network. The network analyzer shows connectivity from the NICs to the RJ45 plugged into the MAU.

What is the most likely cause of this problem?

- A.MAU is set at full duplex
- B.CSU/DSU is disconnected
- C.The ring in and ring out ports between MAUs are misconfigured.
- D.The ring in port of one MAU is connected to a ring out port of other MAU.

Answer: C

A possible cause of this problem is that the new MAU been incorrectly connected to the existing network. The ring in on one MAU should be connected to the ring out on the other MAU.

QUESTION 234

You have just built a small home network that is connected to the Internet via a modem. You, however find that you cannot connect to Host X from your workstation.

A visual examination of your network card, you hub, your router and your modem reveals all link lights are lit. Your network is shown in the following exhibit:

N10-003

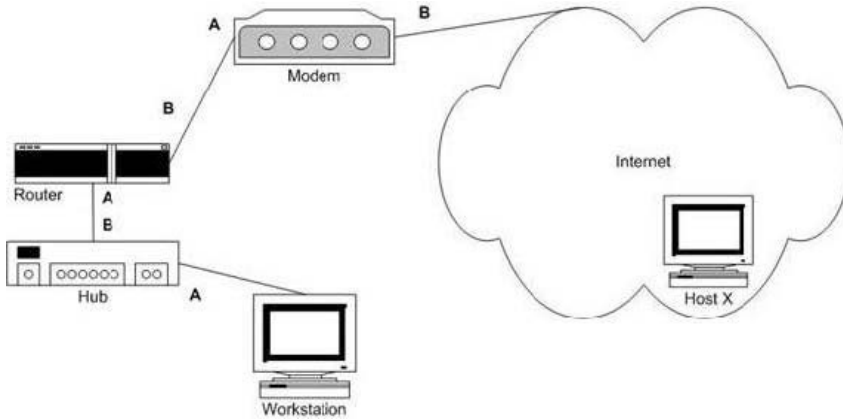

Which component is the most likely cause of this problem?

- A. Misconfigured hub
- B. Misconfigured router
- C. Misconfigured modem
- D. Misconfigured NIC at the workstation

Answer: D

The modem, router, and the hub seem to be working. The most likely is a problem with the local workstation

QUESTION 235

Which device is capable of connecting a computer to a digital data service provided by the local telephone company?

- A. V.34 modem.
- B. Fax machine.
- C. LAN adapter.
- D. ISDN adapter.

Answer: D

Explanation: ISDN (and possibly DSL as well) is a digital service provider by the local telephone company.

Incorrect Answers

- A: A V.34 modem uses the telephone line, but with analog signaling.
- B: A FAX machine uses the telephone line, but with analog signaling.
- C: A LAN adapter cannot be used to connect to the telephone line.

QUESTION 236

You have just built a small home network that is connected to the Internet via a modem. You, however, find that you

cannot connect to Host X from your workstation.

A visual examination of your network card, your hub, your router, and your modem reveals that lights are lit

except the

light in interface A of the hub.

Your network is shown in the following exhibit:

N10-003

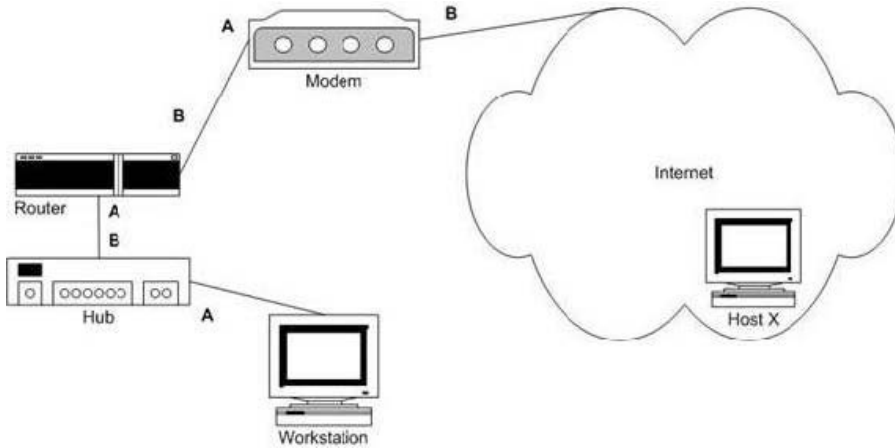

What component is the most likely cause of this problem?

- A. The hub
- B. The router
- C. The modem
- D. The patch cable

Answer: D

Explanation: A faulty patch card might prevent communication on an interface. The light on the interface would not be lit.

Incorrect Answers

- A: Other lights, in particular interface B, on the hub is lit. The hub is not likely to cause the problem.
- B: The router is not connected to the hub.
- C: The modem is not connected to the hub.

QUESTION 237

Which of the following devices usually provides hardware data loopback capabilities? (Choose two)

- A. modems
- B. bridges
- C. Ethernet hubs
- D. CSU/DSUs
- E. Wireless access points

Answer: C, D

Explanation: CSU/DSU provide hardware data loopback testing capabilities. Ethernet hubs also typically provide loopback capabilities.

QUESTION 238

Which of the following devices provides a path between a node on one LAN and a node on another LAN? (Choose three)

- A. A hub

N10-003

- B.A bridge
- C.A router
- D.A switch
- E.A managed hub

Answer: B, C, D

Explanation:

B:A bridge connects two networks segment.

C:A router routes traffic between different networks.

D:A switch works like a hub, but it reduces broadcasts and provides better bandwidth.

Note:An unmanaged hub is a black box that has a prescribed job to do and does it according to its design. In general,

there is no way to alter its operations through a network interface.

A managed hub has at least alerting capabilities with some type of SNMP or HTTP mechanism that might allow an

administrator to change the operation of the hub in some way for instance, to shut down a port connecting to a certain

system or device.

Incorrect Answers

A:A hub is used to connect network devices within a LAN.

E:A managed hub is just a hub which can be configured.

QUESTION 239

NO: 5

Which of the following devices can you use to connect computers with wireless adapters to a network?

- A.A hub
- B.A router
- C.A switch
- D.An access point

Answer: D

Explanation: Access points isused to connect wireless computers to the network.

Incorrect Answers

A, B, C:Hubs, routers and switches connects devices with wires.

QUESTION 240

The Data Link Layer is capable of supporting the operation of various devices. Which of the following devices operates

at the Data Link layer? (Choose all that apply.)

- A.Hub
- B.NICs
- C.Router
- D.Switches
- E.Bridges

N10-003

Answer: B, D, E

B:The data link layer is concerned with physical addressing, the MAC addresses which are stored in the NICs.

D:Layer-2 switches are fast because they do not look at the Network layer header information, looking instead at the

frame's hardware addresses before deciding to either forward the frame or drop it.

E:A bridge is used to break larger network segments into smaller network segments. It works much like a repeater, but

because a bridge works solely with Layer 2 protocols and layer 2 MAC sublayer addresses, it operates at the Data

Link layer.

Incorrect Answers

A:Hubs work at the physical layer.

C:Routers work at the network layer.

QUESTION 241

What UART chip is necessary to provide a modem connection of 115200 bps?

A.85.xx

B.65.xx

C.100.xx

D.165.xx

Answer: D

Explanation: Most computers today have 16550 UART chips for both of their serial ports, which can run as fast as

256 Kbps.

QUESTION 242

Which of the following connectors can be used with external SCSI interfaces? (Choose three.)

A.DB-25 Female

B.Centronics-36

C.Centronics-50

D.High density 68-pin

E.DB-9 Male

F.RJ-11

Answer: A, C, D

Explanation:

A:DB-25 female adapter are used on some older SCSI implementations.

C:The earliest SCSI implementations used a 50-pin Centronics connector for external connections

D:Later SCSI implementations use unique 50-pin HighDensity or 68-pin High-Density connectors on their cables.

Incorrect Answers

B:A 36-pin Centronics connector is used to connect to printer (print device).

N10-003

E:DB-9 male cannot be used as a SCSI connector. It has too few connectors.
F:RJ-11 is used to connect a telephone.

QUESTION 243

Which hub type is capable of boosting signal strength?

- A.Passive hubs
- B.Hybrid hubs
- C.Token hubs
- D.Active hubs

Answer: D

Explanation: Active hubs regenerate the signals.

Incorrect Answers

A:Passive hubs just distributethe signals.

B:The notion of hybrid hubs would apply the USB hubs that are both bus powered and self-powered.However, a hybrid hub could be either passive or active.

C:MAU are hubs that are used in token rings. MAUs are not called token hubs.

QUESTION 244

You are the administrator of the Certkiller network which consists of 250 nodes.You want to implement video conferencing, but your network is performing poorly.Through network work analysis software, you determine that the hub is the bottleneck.Which device should you install in place of the hub to address the problem of the bottleneck?

- A.A MAU
- B.A switch
- C.A repeater
- D.A transceiver

Answer: B

Explanation: Thecapacity on the hub areshared by all ports, but a switch increases performance by giving each port on the switch the full capacity. For example, on a 100Mbps switch each port has 100Mbps capacity at all times.

Incorrect Answers

A:A MAU is a specialized hub used in token ring networks.

C:A repeater only regenerates the signal. It does not affect the speed.

D:A transceiver is used to connect the network adapter with the network media. It is not a bottleneck, it is just a connector.

QUESTION 245

Which of the following header fields can be used to route datagrams?

- A.A port address
- B.A MAC address

- C.A source address
- D.A destination address

Answer: D

Explanation: A router uses the destination address to decide where to send the data next when it routes data.

Incorrect Answers

A:The port address is used when filters are applied, not to route data.

B:Routers work at the network layer of the OSI model. MAC address belongs to the Data Link layer. Switches and

bridges use MAC addresses to forward data in the correct direction.

C:The source address is not used when routing data.

QUESTION 246

You have just built a small home network that is connected to the Internet via a modem. You, however find that you

cannot connect to Host X from your workstation.

A visual examination of your network card, you hub, your router and your modem reveals that the link lights on the

interface A of the router and interface B of the hub are not lit.

Your network is shown in the following exhibit:

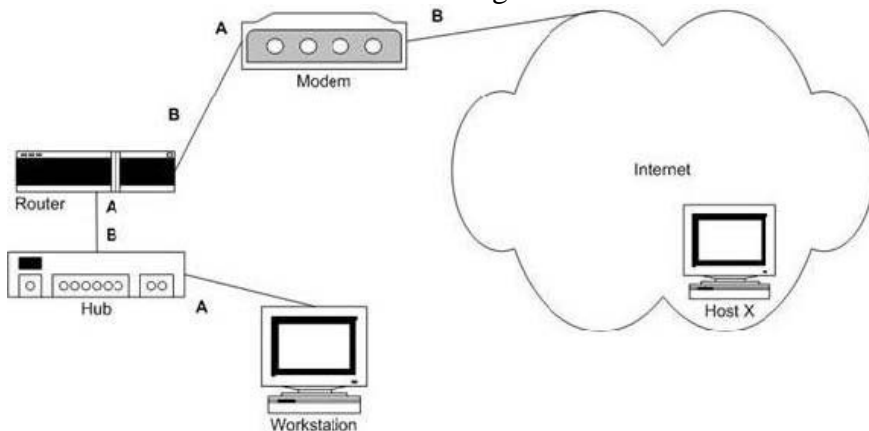

Which component is LEAST likely to have failed?

- A.The hub
- A.The modem
- B.The router
- C.The patch cable

Answer: B

Explanation:

The modem is not related to this problem.

The problem is between the router and hub. It could a problem with the router, the port, the hub, or it could be the

patch cable between the hub and the router that is bad.

QUESTION 247

Which router on your segment is the destination for all the packets that are destined for the remote network?

- A. Bridge
- B. Switch
- C. Default Gateway

Answer: C

Explanation: All non-local traffic must pass the router.

Incorrect Answers

A: A bridge only connects two network segments.

C: A switch is just a more efficient hub. A switch transmits data-

QUESTION 248

Which of the following types of hubs is limited to supporting distances of less than 30 meters (100 feet)?

- A. An active hub
- B. A hybrid hub
- C. A passive hub
- D. A switching hub

Answer: C

Explanation: Maximum distance between a Passive Hub and an Active Hub or a workstation is 30 meters.

Incorrect Answers

A: Active hubs support 100m in a 100BaseT network for example.

B: A hybrid hub would be a hybrid between a switch and hub. Switching hubs do support 100 meters of distance in a

100BaseT network for example.

D: Short for portswitching

hub, a special type of hub that forwards packets to the appropriate port based on the

packet's address. Switching hubs do support 100 meters of distance in a 100BaseT network for example.

QUESTION 249

Which of the following represents a multiport device capable of connecting network segments and allowing full bandwidth on all ports?

- A. Repeater
- B. Hub
- C. Switch
- D. MAU
- E. All of the above

Answer: C

Explanation: A switch allows full bandwidth on all ports.

Incorrect Answers

A: A repeater only repeats the signals.

N10-003

B:A hub splits the available bandwidth between the ports on the hub.

D:A MAU is a hub used in token ring network.

QUESTION 250

You are the network technician at your company. You install a new PCI 100BaseT NIC in a Windows 95

workstation. However, the workstation cannot see any of the other computers on the network. The other workstations

on the network are operating correctly. You verify that the configuration settings for the NIC are correct. You also

ensure that the patch cable is not faulty.

What additional troubleshooting method should you take?

A. Do an internal MAU loopback.

B. Do an external MAU loopback.

C. Do an internal hardware loopback.

D. Do an external hardware loopback.

Answer: D

Explanation: We should test the NIC. This can be accomplished by using an external hardware loopback.

Incorrect Answers

A, B: MAUs are hubs used in token ring networks. Ethernet networks do not use MAUs.

C: There is no such thing as an internal hardware loopback.

QUESTION 251

You want to configure a workstation for dialup

networking. You install an ISA internal modem in the workstation using

the standard settings. The modem operates on COM2. However, you cannot initialize the modem.

What is the most likely cause of this problem?

A. Conflict with IRQ3.

B. Conflict with IRQ4.

C. Incorrect IP addressing.

D. Incorrect IPX addressing.

Answer: A

Explanation: This is a likely hardware conflict problem. Two devices are using the same IRQ. COM2 uses IRQ3.

Incorrect Answers

B: COM2 does not use IRQ4.

C, D: This is not a network configuration problem. You don't have to configure network protocols in order to initialize a modem.

QUESTION 252

You need to connect a Token Ring network to an AppleTalk network. What device should you use?

- A.hub
- B.bridge
- C.switch
- D.gateway

Answer: D

A gateway is used to connect dissimilar systems. Here the gateway is used to connect two dissimilar networks.

QUESTION 253

You want to connect a remote office to a corporate network. The only available service is an analog data service provided by the local telephone company. What device would you need to make use of this service?

- A.Fax machine
- B.V.90 modem
- C.ISDN adapter
- D.LAN adapter

Answer: B

A V.90 modem is used to connect local ISP using the telephone line.

QUESTION 254

What network device is used to connect multiple computers to create a single logical network segment?

- A.hub
- B.NIC
- C.router
- D.bridge

Answer: A

A hub connects multiple computers to create a single logical network segment.

QUESTION 255

You work as a network administrator for a company that has a Web server located behind a firewall. The company's network is shown in the following exhibit:

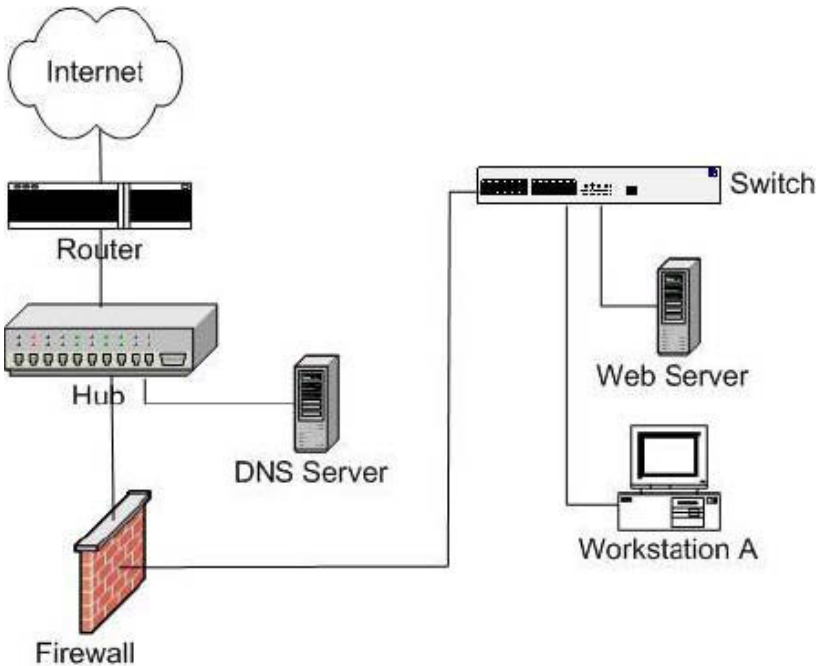

External Web users who connect to the Web server from the Internet complain of intermittent connectivity to the Web server. The user of Workstation A is not experiencing any connectivity problem to the Web server. However, she is complaining that she cannot access the Internet. You confirm that the user can connect to the firewall.

What is the probable cause of this problem?

- A. High utilization on the router
- B. High utilization on the Web server.
- C. A jabbering NIC in the Web server
- D. A jabbering NIC in the DNS server
- E. A bad cable between Workstation A and the switch.
- F. A bad cable between the Web server and the switch.

Answer: A

High utilization of the router could explain both problems.

High utilization of the Web server could not cause intermittent Internet connectivity.

QUESTION 256

Your network consists of two network segments. After moving a workstation from one segment to the other segment, you discover that the workstation can no longer communicate on the network. The network is shown in the following exhibit:

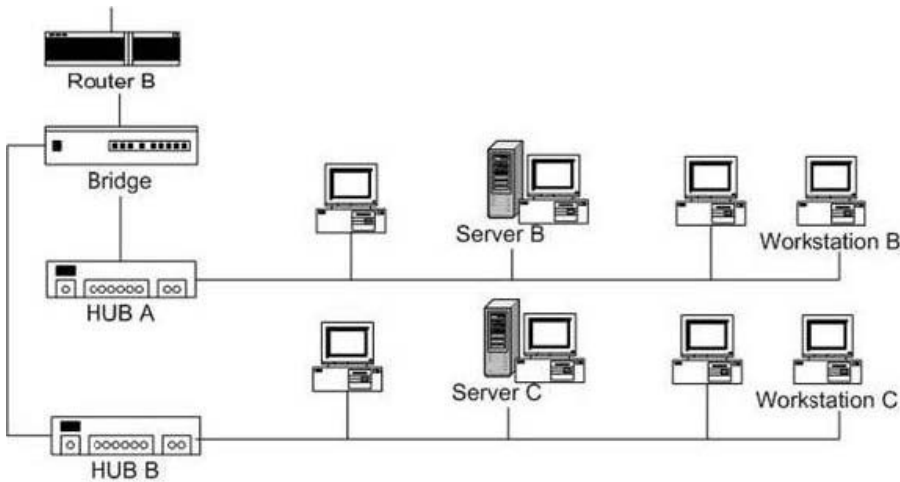

What is the most likely cause of this problem?

- A.hub A
- B.hub B
- C.bridge
- D.router B
- E.patch cable

Answer: E

The problem is only for one particular computer. A possible cause of the problem is the patch cable connecting the computer to the Network.

The other alternatives do not apply since they would affect several computers.

QUESTION 257

You want to build a network in which data transmission is based only on MAC addresses. Which network devices pass data based solely on the MAC address? (Choose all that apply.)

- A.hub
- B.router
- C.bridge
- D.Layer2 switch

Answer: C, D

MAC addresses are placed on Layer 2, the Data link layer, of the OSI model. MAC addresses are stored in Network adapters.

C:A bridge is used to connect two network segments. A bridge operates at the Data link layer and uses a table of learned MAC addresses to forward data to the correct destination.

D:Ordinarily switches work at layer 2 of the OSI layer. These switches use MAC addresses to forward data to the correction destination.Layer 3 switches are able to work both at layer 2 and layer 3.

Incorrect Answers

A:A hub operates at the physical layer, layer 1,forwardingsignals.

B:A router operates at the network layer, layer 3. Typically a router use IP addresses to route data throughout

the
network.

QUESTION 258

You are implementing an ISDN connection to the Internet. How many 64 Kbps channels does a BRI ISDN connection support?

- A.1
- B.2
- C.3
- D.12

Answer: B

A BRI ISDN connection supports two 64Kbps channels.

QUESTION 259

You are building a sophisticated network. One of your objectives is to avoid unnecessary network traffic. You therefore do not want to use network devices that direct the data packet to all hosts on the LAN segment. What device should you avoid using?

- A.hub
- B.router
- C.switch
- D.gateway

Answer: A

A hub directs data packets to all devices connected to the hub.

QUESTION 260

You work as a network technician for your company. The NIC on one of the company's workstations has failed. You replace the NIC but now the workstation cannot log on to the server. What should you do to determine the most likely cause of the problem?

- A.Reboot the server
- B.Reboot the workstation
- C.Run diagnostics on the server's NIC
- D.Run diagnostics on the workstation's NIC

Answer: D

The replaced device should be checked.

QUESTION 261

You are in the process of dividing a large IP network into smaller subnets. Which of the following statements holds true

for IP subnets? (Choose all that apply.)

- A.An IP router connects two subnetworks.
- B.Each subnetwork behaves as if it were independent.
- C.Nodes on different subnetworks cannot communicate with each other.
- D.Routing between nodes on different subnets is transparent to the users.

N10-003

Answer: A, B, D

IP subnetworks are connected by IP routers which enables communication between the subnets. Each IP subnetwork can function independently. Users are not directly aware of the routing between the subnets.

QUESTION 262

You work at the help desk of an ISP. A customer calls to complain about the speed of his ISDN line. He is using a single BRI ISDN circuit switched B channel. What should his transmission rate be?

- A.56 Kbps
- B.64 Kbps
- C.128 Kbps
- D.258 Kbps
- E.512 Kbps

Answer: C

The transmission rate of a single (out of two) BRI ISDN B channel is 64Kbps.

QUESTION 263

You work as a network administrator for a company that has a Web server located behind a firewall. The company's network is shown in the following exhibit:

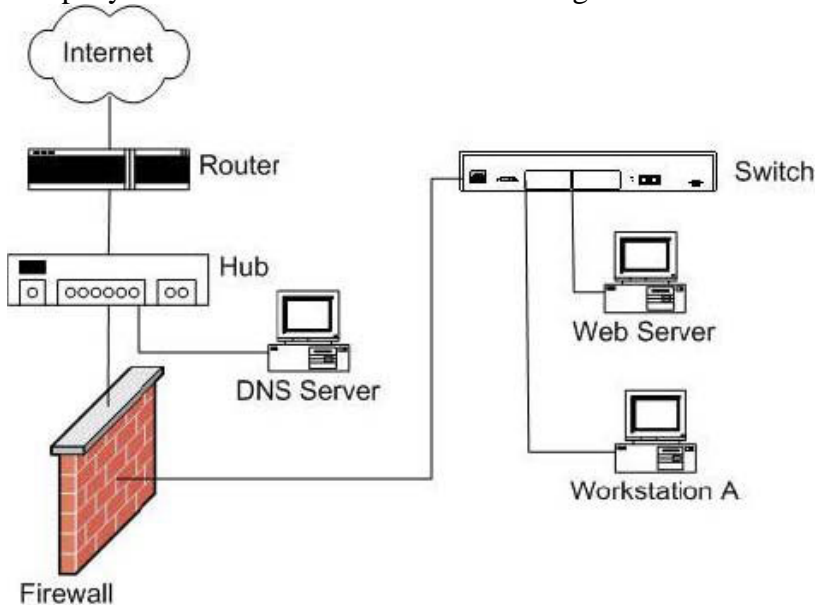

External Web users who connect to the Web server from the Internet complain of slow connectivity to the Web server. In addition, the user of Workstation A complains that she cannot access the internet. You confirm that the user can connect to the firewall.

What is the probable cause of this problem?

- A.High utilization on the router
- B.High utilization on the Web server.
- C.A jabbering NIC in the Web server
- D.A jabbering NIC in the DNS server
- E.A bad cable between Web server and the switch

N10-003

F.A bad cable between Workstation A and the switch

Answer: C

The problem only concerns connectivity to the Web server. A jabbering NIC on the web server could cause slow access.

A bad cable would cause interruptions of the communication, not slow access.

A jabbering NIC on the DNS server would cause problems for all DNS traffic, including internet access.

QUESTION 264

You work as a network technician for your company. Your company has a Token Ring network. The NIC on one of the company's workstations has failed. You replace the NIC but now the workstation cannot communicate with the server.

What is the most likely cause of this problem?

- A.The NIC has the wrong gateway
- B.The NIC has the wrong IP address
- C.The NIC is set for the wrong speed.
- D.The NIC has the wrong subnet mask
- E.The NIC is plugged into the wrong slot.

Answer: C

All NICs on a token ring network must operate at the same speed.

QUESTION 265

You work as a network technician for your company. You need to check the electrical signals being sent out of a port on a NIC. Which device would you require?

- A.An amp meter
- B.A tone generator
- C.A crossover cable
- D.A hardware loopback

Answer: D

A hardware loopback checks outgoing signals of a device.

QUESTION 266

Of which network utility is the following printout from?

```
Internet AddressPhysical AddressType
10.36.14.920060087543d7static
197.45.367.42205332450000dynamic
123.34.34.34205354670000dynamic
```

- A.NETSTAT
- B.NBTSTAT
- C.ARP
- D.Ipconfig

Answer: C

N10-003

Explanation: The exhibit displays entries that contain both IP address and MAC address (Physical Address). These entries are contained in the ARP cache and could be displayed with the "arp" command.

Incorrect Answers

A: Netstat displays information about the traffic generated by the various TCP/IP protocols.

B: Nbtstat.exe displays information on the NetBIOS over TCP/IP connections.

D: Ipconfig is used to display and configure IP.

QUESTION 267

A user is experiencing problems in accessing the local Intranet web site. How will you go about determining whether the problem is related to this user's workstation only?

A. Run WINIPCFG.

B. Try accessing the Intranet from another workstation.

C. Run TRACERT to the Intranet from the user's workstation.

D. Try to PING the Intranet from the user's workstation.

Answer: B

Explanation: We should try to access the local web site from another computer. If that is possible, we would have reason to believe that the problem was only the workstation of this user.

Incorrect Answers

A, C, D: If we are troubleshooting the computer locally we could not be sure if the problem is related to this workstation alone. We must use other workstations as well.

QUESTION 268

What does one call the unique number that is stamped onto every Ethernet card ever made?

A. Hosts Address

B. Serial Number

C. IP Address

D. MAC Address

Answer: D

Explanation: Every Network Adapter has a unique Media Access Control (MAC) address.

Incorrect Answers

A: A host address is a logical address, not a physical address, typically an IP address.

B: Network adapters have MAC addresses not serial numbers.

C: A network adapter could be configured with different IP addresses.

QUESTION 269

Which of the following is a valid MAC address?

N10-003

- A.0x000000F7
- B.255.255.255.244
- C.00:04:75:0D:81:G2
- D.00:B0:D0:5A:E1:B5
- E.0103FBA1:00000001

Answer: D

A MAC consists of six hexadecimal numbers. The highest possible hexadecimal number is FF:FF:FF:FF:FF:FF. thus,

G2 is not a valid hexadecimal number. The first three bytes contain a manufacturercode,the last three bytes contain a unique station ID.

QUESTION 270

NO: 5

You are analyzing a NIC's MAC address. The MAC address is 00 04 75 94 D4 5C. What do the last three octets identify?

- A.The device ID
- B.The type of device
- C.The manufacturer of the device
- D.The network address of the device

Answer: A

This is a MAC address. The first three bytes contain a manufacturercode,the last three bytes contain a unique station ID.

QUESTION 271

Which of the following is the OSI layer responsible for establishing, managing, and terminating communications between two computers?

- A.Layer 7
- B.Layer 6
- C.Layer 5
- D.Layer 4
- E.Layer 3
- F.Layer 2
- G.Layer 1

Answer: C

Explanation: The OSI Layer 5 (Session Layer) controls the establishment the establishing, managing and terminating communications sessions between presentation layers.

Incorrect Answers

A:OSI Layer 7 The application layer is where the user/applications access the network.

N10-003

B:OSI Layer 6 The presentation layer formats data for display by the application.

D:OSI Layer 4 The transport layer provides for both reliable and unreliable delivery and error correction before retransmit.

E:OSI Layer 3 The network layer provides logical addressing which device us for path destinations.

F:OSI Layer 2 The data link layer combines bits into bytes and bytes into frames, provided access to media using

MAC addresses, and error detection.

G:OSI Layer 1 (physical layer) is responsible to move bits between devices and specifies voltage, wire speed and pin-out cables.

QUESTION 272

A switch is used to link network nodes. According to industry standards, at which OSI layer does a switch operate?

- A.Network
- B.Physical
- C.Transport
- D.Data Link

Answer: D

A switch operates at OSI layer 2 (Data-link)

QUESTION 273

You are troubleshooting a network problem using the OSI reference model. You are focusing on the layer that is

responsible for dividing data into frames so it can be sent across a network.

What layer are you dealing with?

- A.Application
- B.Presentation
- C.Session
- D.Transport
- E.Network
- F.Data Link
- G.Physical

Answer: D

The Transport layer disassembles DATA into segments by TCP.

QUESTION 274

You want to use the OSI reference model to troubleshoot a NIC (Network Interface Card). Which OSI layers will you focus on? (Choose all that apply.)

- A.Session
- B.Network
- C.Physical
- D.Data link
- E.Transport

N10-003

- F.Application
- G.Presentation

Answer: C, D

A Network Interface Card (NIC) operates at the physical and the data link layer of the OSI model.

QUESTION 275

Signals are placed on a cable at which of the following layers of the OSI model?

- A.The Physical Layer
- B.The Data Link Layer
- C.The Network Layer
- D.The Transport Layer

Answer: A

Explanation: The physical layer is responsible to move bits between devices and specifies voltage, wire speed and pinout cables.

Incorrect Answers

B:The data link layer combines bits into bytes and bytes into frames, provided access to media using MAC addresses, and error detection.

C:The network layer provides logical addressing which device us for path destinations.

D:The transport layer provides for both reliable and unreliable delivery and error correction before retransmit.

QUESTION 276

You need to troubleshoot OSI Network layer addressing. Which of the following protocols would you check? (Choose all that apply.)

- A.IP
- B.IPX
- C.TCP
- D.SPX
- E.NetBEUI

Answer: A, B

The IP and IPX protocols are OSI network layer protocols.

QUESTION 277

Which of the following OSI layer 4 protocols provide connectionless-oriented services? (Choose all that apply.)

- A.IP
- B.PPP
- C.TCP
- D.UDP
- E.ICMP

Answer: D
UDP provided connectionless services.

QUESTION 278

You want to use the OSI reference model to troubleshoot a repeater. Which OSI layer will you focus on?

- A.Session
- B.Network
- C.Physical
- D.Data link
- E.Transport
- F.Application
- G.Presentation

Answer: C
A repeater regenerates the signals and work on the physical OSI layer.

QUESTION 279

Which of the protocols mentioned below is used across the Internet for time synchronization purposes?

- A.NTP
- B.NCP
- C.NTFS
- D.NNTP

Answer: A

Explanation: Network Time Protocol (NTP) is an Internet standard protocol which enables client computers to maintain system time synchronization

QUESTION 280

POP is identified by which TCP/IP port number?

- A.21
- B.23
- C.25
- D.80
- E.110

Answer: E

Explanation: POP use TCP port 110.

Incorrect Answers

- A:FTP uses TCP port 21.
 - B:Telnet use TCP port 23.
 - C:SMTP use TCP port 25.
 - D:HTTP uses TCP port 80.
-

QUESTION 281

Which of the following network protocols makes use of zone to provide interoperability between Macintosh users?

- A.TCP/IP
- B.IPX/SPX
- C.NetBEUI
- D.AppleTalk

Answer: D

Explanation: The AppleTalk protocol use zones to divide the network into segments.

Incorrect Answers

- A:TCP/IP uses the network mask to divide the network into segments.
- B:IPX/SPX use network numbers to divide the network into segments.
- C:NetBEUI only use broadcasts.

QUESTION 282

Which protocol is capable of collecting network management information?

- A.SGML
- B.SMTP
- C.SNMP
- D.SMDS

Answer: C

Explanation: Simple Network Management Protocol (SNMP) is used to monitor network traffic.

Incorrect Answers

- A:SGML (Standard Generalized Markup Language) is a markup language and is not used for network management.
- B:Simple Mail Transfer Protocol (SMTP) is used for email.
- D:Switched Multimegabit Data Service (SMDS) is a WAN networking technology used for communication over public data networks. It is not used to monitor networks.

QUESTION 283

A contractor added a DHCP server to the Certkiller 200node network. The contractor was instructed to use the same range of address that was being used previously. You, the network administrator, are able to make manual changes to

most of the machines, but some machines are in locked areas.

Which error messages should you expect to encounter on those machines?

- A.IP address conflicts
- B.IPX address conflict
- C.NIC address conflicts
- D.Server address conflicts

N10-003

Answer: A

Explanation: In this scenario we are migrating a network from static IP addresses to dynamic IP addresses. The same IP

address range should be used. If we keep some static addresses the DHCP server could at some point lease an address

that already is in use. This would result in an IP address conflict.

Note: A DHCP server automates IP configuration of computers.

Incorrect Answers

B: DHCP is a TCP/IP tool, not a IPX tool.

C: NIC addresses are physical addresses and cannot be configured.

D: On an IP network servers do not have special addressing.

QUESTION 284

A Windows NT workstation is moved from one network segment to another within your local network.

However, after

the move, you find that the workstation is no longer able to connect to one of the Windows NT servers it previously

used. The workstation is configured to use NetBEUI. What is the most likely source of the problem?

A. The workstation is making use of routable protocol.

B. The workstation is making use of a nonroutable protocol.

C. The router between the segments is blocking port 139.

D. The router between the segments is blocking port 193.

Answer: B

Explanation: NetBEUI is a nonroutable protocol. NetBEUI traffic cannot reach outside the local network segment.

Incorrect Answers

A: NetBEUI is non-routable.

C, D: NetBEUI is a broadcast only protocols and NetBEUI traffic will be blocked by a router.

QUESTION 285

Which two items will enable you to connect a Windows 9x machine to a Novell server? (Choose two)

A. NetWare

B. IPX/SPX

C. NetBEUI

D. Client for NetWare Networks.

Answer: B, D

Explanation: The client needs a protocol that is supported by NetWare. The native protocol of NetWare is SPX/IPX.

We also need software which enables the client to emulate a Novell client. We can use client for NetWare Networks.

Incorrect Answers

A:NetWare is the name of Novell's network OS.

C:NetBEUI is not supported by Novell.

QUESTION 286

At Certkiller there are several LANs. Which of the following protocols can you use on these LANs to make LAN to

LAN communication possible? (Choose three.)

A. IPX/SPX

B. LAT

C. PPP

D. TCP/IP

E. NetBEUI

F. AppleTalk

Answer: A, D, F

Explanation:

IPX/SPX, TCP/IP, and AppleTalk are all routable protocols and can all be used for interLAN communication.

Incorrect Answers

B: LAT does not apply here.

C: PPP is used for WAN connections connecting LANs. PPP cannot be used as a LAN protocol

E: NetBEUI is not routable and can therefore not be used when LAN to LAN communication is required.

QUESTION 287

Which of the following TCP/IP protocols can be used by your email client to download mail from the server?

A. FTP

B. POP3

C. SMTP

D. SNMP

Answer: B

Explanation: POP3 is the most recent version of a standard protocol for receiving email.

POP3 is a client/server

protocol in which email

is received and held for users by their email

server.

Note: POP stands for Post Office Protocol.

Incorrect Answers

A: FTP is used to transfer files.

C: SMTP is used for sending email

and for communication between email

servers.

D:SNMP is used to monitor network traffic.

QUESTION 288

Which of the following can you use to transfer a file from a UNIX server to yours?

- A.Netstat
- B.FTP
- C.Telnet
- D.NBTSTAT

Answer: B

Explanation: FTP (File Transfer Protocol) can be used to transfer files between different computer systems.For example between UNIX and Windows computers.

Incorrect Answers

- A:Netstat displays information about the traffic generated by the various TCP/IP protocols.
 - C:Telnet is used for remote login.
 - D:Nbtstat.exe displays information on the NetBIOS over TCP/IP connections.
-

QUESTION 289

You are installing a NetWare based server system. You have 10 Windows 95 workstations and 4Unixworkstations.

What do you have to install on the Windows 95 systems that will allow you to connect to the NetWare server? (Choose two)

- A.Novell Client for Microsoft Windows systems
- B.Novell Client for Windows
- C.Microsoft Client for Novell NetWare
- D.Novell install suite

Answer: B, C

Explanation: We can either use the Novell Client forWindows,or the Microsoft Client for Novell NetWare.

Incorrect Answers

- A, D:There are no such things.
-

QUESTION 290

You want to browse an NDS tree on a Windows 95/98 system. What client software is will enable you to do so? (Select two)

- A.Novell Client for Windows
- B.Microsoft Client for Novell NetWare
- C.Novell Client for Microsoft Windows systems
- D.Novell install suite

Answer: A, B

N10-003

Explanation: We can either use the Novell Client for Windows, or the Microsoft Client for Novell NetWare. This would

allow the Windows client to connect to the Novell Server and browse the NDS (Novell Directory Services) tree.

Incorrect Answers

C, D: There are no such things.

QUESTION 291

Which of the following is a necessity on your workstation when you want to implement a full suite of network card

diagnostics?

A. Router

B. Hardware loop

C. Protocol analyzer

D. Additional NIC

Answer: B

Explanation: A hardware loop adapter is used to enable the full troubleshooting of a network adapter.

Incorrect Answers

A: A router is used to route data throughout a network.

C: A protocol analyzer is used to analyze traffic on a network.

D: Another network adapter is not required.

QUESTION 292

The following options represent TCP/IP protocols. Which one will be used by a UNIX server to send email to another

UNIX server?

A. POP3

B. SNMP

C. SMTP

D. FTP

Answer: C

Explanation: Simple Mail Transport Protocol (SMTP) is the protocol that email servers use to transmit messages to each other across the Internet.

Incorrect Answers

A: Post Office Protocol (POP3) is one of the protocols that email clients use to retrieve their messages from an email server.

B: Simple Network Management Protocol (SNMP) is a network management protocol.

D: FTP is used for file transfers.

QUESTION 293

You will encounter the need for the most administrative overhead in which of the following routing methods?

N10-003

- A.Bridging
- B.Static
- C.Dynamic
- D.Relay

Answer: B

Explanation: Static routing requires manual configuration of the routing tables. The administrator must add and delete each single route. This can easily get out of hand if the routing tables are large.

Incorrect Answers

A:Bridging is not a routing method. Bridges works at the Data Link layer, layer 2, of the OSI model. Routing takes place at the Network Layer, layer 3.

C:Dynamic routing is automatic. Routers exchange routes between themselves. It requires little or no administrative effort.

D:Relaying is not a routing method.

QUESTION 294

Which of the following protocols will you tell the Certkiller trainee technician to use to connect NT and Netware 5?

(Choose two)

- A.IP
- B.IPX
- C.NetBEUI
- D.DLC

Answer: A, B

Explanation:

A:IP is supported by all modern network operating systems including NT and NetWare.

B:Novell made IPX. Windows support IPX/SPX with the NWLink protocol.

Incorrect Answers

C:NetBEUI is not supported by NetWare 5.

D:DLC is mainly used in IBM mainframes and HP legacy printers.

QUESTION 295

Of the possibilities mentioned below, which are connectionless? (Choose two)

- A.TFTP
- B.NetBEUI
- C.FTP
- D.HTTP

Answer: A, B

N10-003

Explanation:

A:TFTP, Trivial FTP is connectionless.

B:NetBEUI uses broadcasts and is therefore connectionless.

Note:Using connectionless protocols packets are sent over the network without regard to whether they actually arrive

at their destinations. There are no acknowledgments or guarantees.

Incorrect Answers

C:FTP is a connectionoriented application layer TCP/IP tool.

D:HTTP runs of TCP and TCP is connectionoriented.

So HTTP is not connectionless.

QUESTION 296

You implement an application layer proxy server on your network. You now want to implement an Internet protocol

can work with this proxy server.

Which protocols can you use? (Choose all that apply.)

A.FTP

B.HTTP

C.PPTP

D.Telnet

Answer: A, B

Explanation: Application layer proxies are applications running on the firewall, which users on one or both sides of the

firewall can communicate with.

The most common example of an application layer proxy is an HTTP proxy. There also exist FTP proxies which also

work at the application layer.

QUESTION 297

You have installed two routers on your network. You now need to implement protocols that can be routed.

Which

protocols should you implement? (Choose all that apply.)

A.IP

B.IPX

C.TCP

D.NetBEUI

E.NetBIOS

Answer: A, B

Explanation: IP and IPX are network layered protocols and both can be routed.

Incorrect Answers

C:TCP is a transport layer protocol. Network layerprotocol arerouted.

D:NetBEUI is broadcast only and it is not routable.

E:NetBIOS is not a protocol in itself.

QUESTION 298

You are the network administrator for your company. Since 9:30 p.m. users have been complaining of slow access time.

The problem seems to be affecting the whole network. You verify that all workstations, servers, hubs and routers are connected correctly and that there are no conflicts.

You want to isolate the problem. How can you accomplish this?

A. Use loopback hardware.

B. Use the Network Monitor.

C. Issue the NBTSTAT command.

D. Issue the NETSTAT command.

Answer: B

Explanation: We need to monitor the network traffic to find out what is causing all the network traffic.

Incorrect Answers

A: Loopback hardware is used to test the NIC of a computer.

C: Nbtstat.exe is a Windows commandline

program that displays information about the NetBIOS over TCP/IP

connections that Windows uses when communicating with other Windows computers on the TCP/IP LAN.

D: NETSTAT is a command-line program that displays information about a computer's current TCP/IP network connections and about the traf

however it would be better to monitor the network traffic.

QUESTION 299

You are the network technician for a small company. Your company has a Windows NT network. Your company amalgamates with two other small companies. The one company has a Novel NetWare network and the other company has a UNIX network. You need to connect these three networks using a device that can translate between the dissimilar network protocols.

What device do you require?

A. A router

B. A bridge

C. A switch

D. A gateway

Answer: D

Explanation: A gateway can translate between different protocols. A gateway can operate on most of layers in the OSI model.

Incorrect Answers

A: A routing routes data throughout the network. It does not translate protocols. Routers work at the network layer.

N10-003

B:A bridge is used to physically connect two network segments. A bridge works at the Data link layer.

C:A switch connects hosts on a network. It can also function as a router.

QUESTION 300

How will the server know what service incoming packets are intended for in an environment where a UNIX server is

configured to host a web site and an FTP site on the internet?

- A.Protocol ID
- B.Port number
- C.Host header
- D.TCP address

Answer: B

Explanation: Both HTTP and FTP use the TCP protocol. HTTP use TCP port 80 and FTP use TCP port 21. The server will use the port number to distinguish between the traffic.

Incorrect Answers

A:Both HTTP and FTP use the TCP protocol.

C:Host headers are used by web servers to distinguish between virtual sites. It is not used to distinguish between protocols.

D:TCP does not have any address. IP is the address part of the TCP/IP protocol.

QUESTION 301

You are the network technician at your company. You are configuring a Windows NT 4.0 laptop for dialup networking. The laptop will be used by a telecommuter. The telecommuter will use the laptop to dial into a Microsoft Windows NT 4.0 Remote Access Server. Once connected, the telecommuter will need access to a UNIX machine.

What should you install on the laptop? (Choose all that apply.)

- A.TCP/IP Protocol
- B.NetBEUI Protocol
- C.Remote Access Service
- D.Novell Remote Console
- E.IPX/SPX Compatible Protocol
- F.Dial Up Networking

Answer: A, F

We must use the TCP/IP protocol which is the native protocol of UNIX machines.

We also need Dialup networking.

Not C:RAS (remote access service) can only been run on the server.

QUESTION 302

Your supervisor instructs you to start Samba on a UNIX/LINUX server. What benefits does Samba provide? (Choose

all that apply.)

- A.Web access

N10-003

- B.Telnet access
- C.Server access
- D.Print server access

Answer: C, D

A Samba server provides a centralized server authentication and the print server service.

QUESTION 303

You are the network administrator at your company. Your company has Windows NT and Apple Macintosh workstations on its network. You install a network print device on the network. Later, users of Macintosh workstations complain that they are unable to print to the new network print device but can print to any of the other printers on the network. Windows NT users have no problem printing to the device. You reset the printing device.

What should you do next?

- A.Replace the printing device.
- B.Verify the printer connection to the printing device.
- C.Plug the Macintosh network cable in to a different port on the hub.
- D.Ensure that AppleTalk is an installed protocol on the printing device.

Answer: D

Apple clients, with no additional software, require the use of the AppleTalk protocol for printing.

QUESTION 304

Which of the following communication protocols utilize a vector distance protocol to maintain routing table information?

- A.TCP/IP
- B.NetBEUI
- C.IPX/SPX
- D.AppleTalk

Answer: A, C

TCP/IP and IPX/SPX are routable protocols. They use a vector distance protocol to maintain routing table information.

NetBEUI and AppleTalk are not routable.

QUESTION 305

You are a network administrator at your company. Your company has a firewall that blocks all communication. You, however, want to allow users to send email messages. What protocol should you allow through the firewall so that users can send email messages?

- A.FTP
- B.TFTP
- C.POP3
- D.SMTP
- E.SNMP

Answer: D

The Simple Mail Transfer Protocol (SMTP) in most email programs to send email messages. POP3 is used to receive email messages.

QUESTION 306

You are troubleshooting an IP network. Which protocol can you use for error reporting on the network?

- A.SMTP
- B.ICMP
- C.NNTP
- D.SNMP

Answer: B

The Internet Control Message Protocol (ICMP) is used for IP error reporting and IP maintenance traffic.

QUESTION 307

Which dial-up protocol is capable of passing multiple LAN protocols across the wire?

- A.PPP
- B.SLIP
- C.POTS
- D.TCP/IP

Answer: A

PPP is able to encapsulate different network protocols such as NetBEUI, IPX/SPX, and TCP/IP.

QUESTION 308

You are a network administrator at Certkiller , Inc. You install a new workstation to the Certkiller network. However, the new workstation cannot connect to the network. You verify that TCP/IP information on the workstation is configured correctly. The user uses a static IP address in the correct range for the segment and the subnet mask is correct.

Why is the user not able to connect to the network?

- A.The DHCP server is not available.
- B.The static IP address is a duplicate of one already in use.
- C.A static IP address cannot be used on a network using DHCP.
- D.The user does not have permissions to add a static IP address.

Answer: B

Two workstations cannot use the same IP address on the same network. This might be the reason of the problem.

The other alternatives are false.

QUESTION 309

Which OSI layer is responsible for sequencing?

N10-003

- A.The Physical Layer
- B.The Transport Layer
- C.The Data Link Layer
- D.The ApplicationLayer
- E.The Presentation Layer

Answer: C

Explanation: The data link layer combines bits into bytes and bytes into frames, provided access to media using MAC addresses, and error detection. Furthermore, it provides sequencing of frames.

Incorrect Answers

A:The physical layer is responsible to move bits between devices and specifies voltage, wire speed and pinout cables.

B:The transport layer provides for both reliable and unreliable delivery and error correction before retransmit.

D:The application Layer is where the user/applications access the network.

E:The Session Layer controls the establishment the establishing, managing and terminating communications sessions between presentation layers.

QUESTION 310

The new Certkiller trainee technician wants to know which OSI layerdoes a bridge operateunder. What will your reply be?

- A.The Session Layer
- B.The Data Link Layer
- C.The Transport Layer
- D.The Network Layer

Answer: B

Explanation: Bridges work at the Data Link layer, layer 2, of the OSI model. Bridges use MAC address to forward data to the correction destination.

Incorrect Answers

A,C:No particular network device work at the session or at the transport layer.

D:Routers work at the network layer.

QUESTION 311

Which of the following OSI layers makes sure that packets are delivered error free and without any losses?

- A.The Network Layer
- B.The Transport Layer
- C.The Physical Layer
- D.The Data Link Layer

Answer: B

N10-003

Explanation: The transport layer provides for both reliable and unreliable delivery and error correction before retransmit. The transport layer ensures that packets are delivered error free, in sequence, and without losses.

Incorrect Answers

A: The network layer provides logical addressing which devices use for path destinations.

C: The physical layer is responsible to move bits between devices and specifies voltage, wire

D: The data link layer combines bits into bytes and bytes into frames, provides access to media using MAC addresses, and error detection. speed and pinout cables.

QUESTION 312

You have been requested to connect three network segments where one segment is using TCP/IP and NetBEUI, and the other two segments use NetBEUI alone. Which hardware device will you find is the most appropriate to use?

- A. A hub
- B. A router
- C. A gateway
- D. A brouter

Answer: D

Explanation: A brouter could bridge NetBEUI traffic and route TCP/IP traffic. This would be the most effective solution.

Incorrect Answers

A: A hub would connect the two network segments, however network performance would decrease.

B: NetBEUI is not routable. NetBEUI traffic would not be able to pass the router.

C: A gateway is not necessary. No translation between protocols is required.

QUESTION 313

At which OSI layer do Routers operate?

- A. The Transport Layer
- B. The Network Layer
- C. The Data Link Layer
- D. The Application Layer

Answer: B

Explanation: Routers work at layer 3 of the OSI model, the Network layer. Routers route traffic.

QUESTION 314

There are different OSI layers. At which layer do Email and FTP services work?

- A. The Presentation Layer
- B. The Session Layer
- C. The Application Layer

Answer: C

Explanation: E-mail and FTP services operate at the application layer of the OSI layer. Other application layer protocols/services are Telnet, SMTP, SNMP, DNS, and HTTP.

QUESTION 315

UDP resides at which layer of the OSI model?

- A.session
- B.network
- C.physical
- D.transport
- E.data-link
- F.application
- G.presentation

Answer: D

Explanation: UDP is connectionless transport layer protocol

QUESTION 316

You are troubleshooting a network device that operates at the Network and Data Link layers of the OSI reference model. Which of the following components are you troubleshooting?

- A.A NIC.
- B.A Router.
- C.A Bridge.
- D.A Brouter.

Answer: D

Explanation:

A brouter combines the function of a bridge and a router. A router operates at the Network layer while a bridge operates at the Data Link layer. Thus, a brouter operates both at the Network and the Data Link layer.

Incorrect Answers

- A:A NIC operates at the Data Link Layer.
 - B:A router operates only at Network layer.
 - C:A bridge operates only at the Data Link Layer.
-

QUESTION 317

You are troubleshooting a network problem using the OSI reference model. Which OSI level would you focus on when troubleshooting the OSI layer that handles networking functionality?

- A.Application
- B.Presentation
- C.Session
- D.Transport
- E.Network

F.DataLink
G.Physical

Answer: G

The Physical layer handles networking functionality.

QUESTION 318

You are the network technician at your company. The network segment in your office is IP network 172.17.0.0/16 and includes a router with the IP address set to 172.17.0.1.

What is the gateway for the workstations on this network segment?

- A.127.0.0.1
- B.172.17.0.0
- C.172.17.0.1
- D.255.255.0.0
- E.255.255.255.0

Answer: C

The default gateway is often the IP address of the local LAN interface of the router.

QUESTION 319

On an IP network, what function does a default gateway provide?

- A.It provides an IP address for a client workstation.
- B.It provides address translation of an IP address to a host name.
- C.It provides a route for packets with destinations outside the local subnet.
- D.It provides a pointer to the home server address for the client workstation.

Answer: C

A default gateway enables access to resources outside the local subnet.

QUESTION 320

You have just built a small home network that is connected to the Internet via a modem. You, however find that you cannot connect to Host X from your workstation.

A visual examination of your network card, your hub, your router and your modem reveals that all link lights are lit

except the link lights on Interface A of the router and interface B of the hub.

Your network is shown in the following exhibit

N10-003

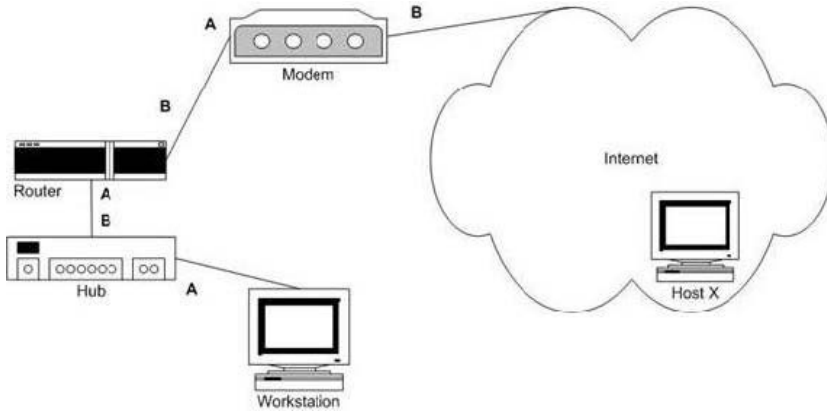

Which component could NOT have caused this problem?

- A. The hub
- B. The router
- C. The modem
- D. A patch cord

Answer: C

The hub, the router, or the cable connecting them could be defective. The modem could not cause this problem.

QUESTION 321

Place each common protocol name next to its corresponding port number.

Name	Port Number	Select from these
<input type="text" value="Place here"/>	<input type="text" value="21"/>	<input type="text" value="HTTP"/>
<input type="text" value="Place here"/>	<input type="text" value="23"/>	<input type="text" value="SMTP"/>
<input type="text" value="Place here"/>	<input type="text" value="25"/>	<input type="text" value="FTP"/>
<input type="text" value="Place here"/>	<input type="text" value="80"/>	<input type="text" value="POP3"/>
<input type="text" value="Place here"/>	<input type="text" value="110"/>	<input type="text" value="Telnet"/>

Answer:

Name	Port Number
FTP	21
Telnet	23
SMTP	25
HTTP	80
POP3	110

Select from these

QUESTION 322

Which of the following communication protocols makes use of the Routing Information Protocol (RIP)?
(Choose two)

- A. TCP/IP
- B. NetBEUI
- C. IPX/SPX
- D. AppleTalk

Answer: A, C

Explanation: TCP/IP and IPX/SPX use RIP.

Incorrect Answers

B: NetBEUI is not routable so it does not use any routing protocol.

D: AppleTalk use Apple propriety routing, not standard RIP routing.

QUESTION 323

Which of the following represents mail protocols? (Choose two)

- A. IMAP4
- B. SNMP
- C. POP3
- D. POTS
- E. All of the above

Answer: A, C

Explanation: POP and IMAP are e-mail protocols.

Incorrect Answers

B: Simple Network Monitoring Protocol (SNMP) is used to monitor networks.

D: POTS stands Plain Old Telephone System.

QUESTION 324

A new workstation has been installed in the Certkiller network. The user regularly makes use of a Novell 3.11 server.

However, the user now finds that she is unable to access the Internet.

Which protocol has NOT been installed on the workstation?

- A.DLC
- B.IPX
- C.TCP/IP
- D.Net/BEUI

Answer: C

Explanation: Internet access required the TCP/IP protocol.

Incorrect Answers

A:DLC is used with some HP printers and with IBM computers, not to access Internet.

B:IPX is a Novell protocol. It is not used to access Internet.

D:NetBEUI is a broadcast protocol which only can be used on a single network segment.

QUESTION 325

The Certkiller network has a permanent connection to the Internet. The local network included a Web server and an

SMTP server. As the network administrator you are concerned about the threat of hackers gaining access from the

Internet. You decide to set up filtering on the Internet router. However, after you make this change, your local clients

can no longer download files from an external FTP site. You think the router may be blocking a standard port.

What

port is being blocked?

- A.21
- B.25
- C.110
- D.53

Answer: A

Explanation: FTP uses TCP port 21.

Incorrect Answers

B:SMTP use TCP port 25.

C:POP use TCP port 110.

D:DNS use port 53.

QUESTION 326

Of the possibilities mentioned below which protocols are routable? (Choose two)

- A.NetBIOS
- B.NetBEUI

- C.IP
- D.TCP
- E.IPX

Answer: C, E

Explanation: Routing takes place at the network layer of the OSI model. IP and IPX are routable network layer protocol.

Incorrect Answers

- A:NetBIOS is strictly speaking not a protocol.
- B:NetBEUI only use broadcasts and are not routable.
- D:TCP is a transport layer protocol.

QUESTION 327

The new Certkiller trainee technician wants to know which transport layer protocol can be validated by successfully using FTP. What will your reply be?

- A.IP
- B.TCP
- C.UDP
- D.ICMP

Answer: B

Explanation: FTP uses TCP. TCP connection-oriented is a transport layer protocol.

Incorrect Answers

- A:IP is a network protocol.
- C:UDP is a connection-less transport layer protocol. TFTP, not FTP, uses UDP.
- D:ICMP is an IP management protocol.

QUESTION 328

You are the Certkiller network administrator. At any given time you find that the majority of the 300 users access the same Web sites on the internet through the T1 link. Which Internet technology could you implement to improve the performance of their Web surfing?

- A.IP Proxy
- B.HTTP Proxy
- C.WINS Proxy
- D.FTP Proxy

Answer: B

Explanation:

Hypertext Transfer Protocol (HTTP) provides web access. Proxy servers can help improving performance by local caching. HTTP proxy caches web pages that are accessed.

Incorrect Answers

- A:IP Proxy is used for IP tunneling.
- C:WINS is used for name resolution
- D:FTP is used for file transfers.

QUESTION 329

You are the network technician at your company. You are troubleshooting a workstation that is experiencing network connectivity problems. You notice that the link light on the NIC is not lit. You replace the workstation patch cable but the problem persists. You connect the patch cable to another port in the wiring closet. The light on the NIC is lights. What should you do next?

- A.Replace the NIC.
- B.Replace the NIC driver.
- C.Document the problem and solution.
- D.Attempt to connect and transfer a file.

Answer: D

Explanation: By moving the patch cable to another port at the wiring closet hub we seem to have fixed the problem: the NIC light is on. We should go on an attempt to use the connection.

Incorrect Answers

- A:The NIC light is on so the NIC seems to be functioning.
- B:We have not tried the NIC driver yet. There is no reason to think that is could cause any problem.
- C:It would probably a good idea to document the fact that a port on the closet hub is malfunctioning. However, we should first try to use the connection.

QUESTION 330

A total of 410 users are connected with Cat3 cabling in a star configuration using 10BaseT cabling in the Certkiller network.

Required Results:

- 1.Add 60 more users to the existing network
- 2.Increasing the speed of the network from 10Mbps to 100Mbps

Optional Results:

- 1.Increase the speed of operations on the application server.
- 2.Allow the clients to connect to the server quicker.

Proposed Solution:

- 1.Put 100Mbps cards in the 100 new machines and add them to the network.
- 2.Replace the existing NICs in the clients and the server with 100Mbps cards.
- 3.Add more RAM to the server.
- 4.Change the protocol bindingorderon the clients to put the most used protocol at the top.

Which of the following statements is accurate?

- A.The solution meets the required results and both optional results.
- B.The solution meets the required results and one optional result.
- C.The solution meets the required results and no optional results.

D.The solution does not meet the required results.

Answer: D

Explanation: The speed of the network will not be increased. Cat3 cabling only support 10Mbps. 100Mbps requires Cat5 cabling. The required result is not met.

QUESTION 331

UDP is an example of which type of protocol?

- A.A token transport protocol.
- B.A connectionless protocol.
- C.A packet transport protocol.
- D.A connectionoriented protocol.

Answer: B

Explanation: UDP is a connectionless protocol.

Incorrect Answers

A,C:Token and packet transport do not apply to UDP.

D:TCP is connectionoriented.

QUESTION 332

You are in the process of building a TCP/IP network. Which of the following protocols are valid TCP/IP protocols?

(Choose all that apply.)

- A.SAP
- B.TCP
- C.HTTP
- D.DHCP
- E.NetBEUI

Answer: B, C, D

Explanation:

B:TCP is a transport layer protocol in the TCP/IP protocol suite.

C:HTTP is a TCP/IP protocol is the engine of WWW.

D:DHCP is a TCP/IP which automates the management of IP configuration of hosts.

Incorrect Answers

A:SAP (Service Advertising Protocol) is a protocol used in Novell networks. SAP is used to advertise network services. SAP use IPX/SPX not TCP/IP.

E:NetBEUI is a legacy broadcast protocol originally from IBM. NetBEUI does not support routing and is not a member of the TCP/IP suite.

QUESTION 333

You are in the process of building a TCP/IP network. Which TCP/IP protocol is used to provide logical addresses to a host?

- A.IP
- B.TCP
- C.UDP
- D.SMTP

Answer: A

Explanation: The logical address is a synonym for IP address in the context of TCP/IP.

Incorrect Answers

- B:TCP is a connection-oriented transport layer protocol.
 - C:UDP is a connection-less transport layer protocol.
 - D:SMTP is used for transferring mails.
-

QUESTION 334

You work as a network administrator at your company. The company's local network includes multiple services and has a permanent connection to the Internet. You are concerned about hackers gaining access to your FTP server from the Internet.

Which TCP/IP port should you block on the firewall?

- A.21
- B.23
- C.25
- D.80
- E.110

Answer: A

FTP uses TCP port 21.

QUESTION 335

Your company has a Novel NetWare network. Recently, users have been complaining that the network transmissions that they receive are often corrupt. You want to implement a protocol that recovers from lost or corrupted packets during transmission. What protocol should you implement?

- A.IP
- B.IPX
- C.UDP
- D.TCP

Answer: D

TCP is able to recover from lost or corrupted packets.

QUESTION 336

You are an IT consultant. You are asked to implement a solution that provides for security authentication and encryption to a private network for a client machine that needs to connect to a NetWare server inside the private network.

N10-003

Which protocols should you implement to provide this functionality (Choose all that apply.)

- A.TFTP
- B.PPTP
- C.SMTP
- D.SNMP
- E.TCP/IP

Answer: B, E

First we must use a generic network protocol (TCP/IP). Pointtopoint Tunneling Protocol (PPTP) can be used for security authentication and encryption.

QUESTION 337

You want to build a network that uses names as addresses. What protocol must you implement to accomplish this functionality?

- A.IPX
- B.SPX
- C.TCP/IP
- D.NetBEUI

Answer: D

The NetBEUI protocol uses NetBIOS names as addresses.

QUESTION 338

HTTPS is a secure protocol used on the Internet. Upon what protocol is it based?

- A.FTP
- B.SSL
- C.IPSec
- D.Kerberos

Answer: C

HTTPS is based on the Secure Socket Layer protocol (SSL).

QUESTION 339

You have a network that is connected to the Internet for only maintenance purposes. You place a firewall between your network and they Internet. You configure the firewall to permit only UDP traffic. Which network file transfer protocol will be able to pass through the firewall?

- A.NNTP
- B.IRTF
- C.SNMP
- D.TFTP

Answer: D

The Trivial File Transfer Protocol transfers files and use UDP

QUESTION 340

You want to implement Telnet. What protocol must you implement for Telnet?

- A.IP
- B.PPP
- C.TCP
- D.UDP
- E.ICMP

Answer: C

Telnet uses TCP

QUESTION 341

Which of the following is provided by a WINS server?

- A.Hostname to IPX address resolution.
- B.Hostname to IP address resolution.
- C.NetBIOS name to IP address resolution.
- D.NetBIOS name to IPX address resolution.

Answer: C

Explanation: WINS resolves NetBIOS names to IP addresses.

Incorrect Answers

B:DNS provides hostname to IP address resolution, not WINS.

A, D:WINS only works on Windows system and it does not resolve to IPX addresses.

QUESTION 342

You selected TCP/IP and clicked the Properties button found in the Network Properties dialog box in an effort to enable WINS on a Windows 9x machine.

What should you do next?

- A.Click the enable WINS resolution button
- B.Click "specify name resolution," type WINS
- C.Click DNS configuration, click the enable WINS resolution button
- D.Click WINS configuration, click the enable WINS resolution button

Answer: D

Explanation: The procedure is.

- 1.Open TCP/IP properties
- 2.Find the WINS Configuration tab at the top of the window and click it.
- 3.Click the Enable WINS Resolution button.

Incorrect Answers

A:First you must click WINS configuration.

B:There is no specific name resolution configuration available.

C:We want to use DNS not WINS. Furthermore, there is no DNS configuration available

QUESTION 343

Which of the following parameters mentioned below can be configured in your Network Properties? (Choose four)

- A.WINS server IP address
- B.IP address
- C.Gateway
- D.DNS server IP address
- E.IP address of DHCP server

Answer: A, B, C, D

Explanation: WINS server address, DNS server address, IP address (and subnet mask), and default gateway can all

be configured in Network Properties on Windows computers.

Incorrect Answers

The initial communication between a DHCP client and the DHCP server is achieved by broadcasts. There is no need

for the DHCP client to know the IP address of the DHCP server. In fact, this is not configurable.

QUESTION 344

The Certkiller trainee technician wants to know which name resolution system can be used across different common

network platforms. What will your reply be?

- A.DHCP
- B.NetBIOS
- C.DNS
- D.WINS

Answer: C

Explanation:

DNS is used for host name to IP address resolution. TCP/IP is used on most common network platforms.

Incorrect Answers

A:DHCP automates IP configuration of clients.

B:NetBIOS is not a name resolution scheme. It is a type of naming scheme.

D:WINS is used for NetBIOS name to IP address resolution. It can only be used on Windows platforms.

QUESTION 345

What type of problem could be present in a case where you are able to access your Web server by its IP but not

by its

- A.WINS
- B.LMHOSTS
- C.DNS

Answer: C

N10-003

Explanation: DNS is used to resolve host names to IP addresses. This allows use to use host names instead of IP addresses. A failure to use host name indicates a DNS problem.

Incorrect Answers

A:WINS is used for NetBIOS name resolution and cannot be used to resolve host names.

B:The hosts file can be used for host nameresolution,however the LMHOSTS file is used for NetBIOS name resolution

and cannot be used to resolve host names.

QUESTION 346

What is the term that is used to refer to each computer that is assigned a network ID on a TCP/IP network?

A.Name server

B.Workstation

C.Server

D.Host

Answer: D

Explanation: All devices that is assigned a network ID (an IP address), is called a host.

QUESTION 347

After you loaded print services on a server, the service does not appear to have started and is causing problems.

Where

would you look to investigate further in an effort to troubleshoot the situation?

A.Registry

B.Network settings

C.Log file

D.DNS

Answer: C

Explanation: The log files contain alerts and errors regarding network services. Troubleshooting information regarding

the failure of the print service should be found here.

Incorrect Answers

A:It would be very awkward to try the cause of the problem by looking into the registry.

B:The network settings could be a problem. However, it is better to start with checking the log filers for possible errors.

D:The print service should ordinarily not depend on the DNS service. Furthermore it is better to start with checking the

log filers for possible errors.

QUESTION 348

You want to implement a mechanism to resolve a host name on a UNIX server. What mechanism can you use?

A.IPX

- B.ARP
- C.HOSTS
- D.LMHOSTS

Answer: C

Explanation: On a UNIX either a HOSTS file or a DNS server is used for name resolution. These maps host names to IP addresses.

Incorrect Answers

A:UNIX computers do not use IPX protocol.

B:ARP provides IP to MAC address resolution.

D:LMHOSTS file contains NetBIOS to IP address mapping.

QUESTION 349

You are building a small network. You want to implement a network resource that will provide services for network users. What resource should you implement?

- A.ISDN
- B.A Server
- C.A local host
- D.A Workstation

Answer: B

Explanation: Servers provide login services, file services, email services, internet connectivity services, printing services etc. to the users.

Incorrect Answers

A:ISDN provides broadband connectivity. It does not provide a service.

C:A local host does not provide a service.

D:The workstation only provides a very limited amount of services to the users, such as the network browsing service.

QUESTION 350

You are a network technician at your company. You are currently troubleshooting one of the company's workstations. You suspect that there is a TCP session connected from another workstation.

How would you verify that there is an established TCP connection to the workstation?

- A.Ping the other workstation
- B.Issue the netstat command
- C.Issue the tracert command
- D.Issue the ipconfig /all command

Answer: B

The netstat utility provides information on current TCP sessions.

QUESTION 351

You are the network administrator at your company. Your company has numerous Windows 95 and Windows 98

workstations. NetBIOS over TCP/IP is implemented to allow these workstations to communicate with each other.

However, there is a communication problem between two workstations. You want to troubleshoot NetBIOS over

TCP/IP. What command allows you to do this?

- A.ping
- B.tracert
- C.nbtstat
- D.netstat

Answer: C

The nbtstat utility displays protocol statistics and current TCP/IP connections using NBT (NetBIOS over TCP/IP).

QUESTION 352

You want to implement host name resolution on an IP network. What mechanism should you use?

- A.SAP
- B.NDS
- C.DNS
- D.WINS

Answer: C

Explanation: Host name resolution can be implemented by host files or by DNS.

Incorrect Answers

A: SAP (Service Advertisement Protocol) is used in Novell networks to advertise network services.

B: NetWare 4.0, released in 1993, was the first version to include NDS, which at that time stood for NetWare Directory Services, but is now Novell Directory Services.

D: WINS implements NETBios name resolution, not host name resolution.

QUESTION 353

You have just been hired as a trainee network technician at a large company. Your training instructor asks you what the

three characteristics of a public network are. What would you reply? (Choose all that apply.)

- A. IP hosts are directly accessible from the Internet.
- B. Network IP addresses are exposed to the Internet.
- C. Network IP addresses are not exposed to the Internet
- D. Additional network IP addresses must be registered with IANA.

Answer: A, B, D

A public network uses IP addresses registered with IANA

A. The IP addresses and the hosts using the IP addresses are accessible from the Internet.

QUESTION 354

You work as a network administrator for a small company (Company A) that recently merged with a large company (Company B). Prior to the merger, Company A used static name resolution while Company B used DNS to provide name resolution. As part of the merger, the servers from Company A were moved to Company B's server farm and assigned new IP addresses. Now users at Company A can reach other servers in the server farm but cannot reach the servers that were moved.

What should you do to correct the problem?

- A.Delete the HOSTS file
- B.Correct the LMHOSTS file
- C.Create the static NETSTAT entries.
- D.Add a WINS server to the affected network.

Answer: A

DNS replaces the static name resolution schema. DNS and HOSTS file use host names. LMHOSTS file use NetBIOS to IP address resolution.

QUESTION 355

A command output is shown in the following exhibit:

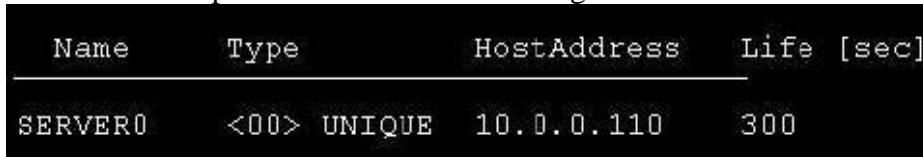

Name	Type	HostAddress	Life [sec]
SERVER0	<00> UNIQUE	10.0.0.110	300

What does this command output indicate?

- A.A tracert to server0
- B.The arp table of server0
- C.The NetBIOS name cache
- D.The NetBIOS connection table

Answer: C

The NetBIOS name cache is shown.

QUESTION 356

You have just built a small home network that is connected to the Internet via a modem. The network includes five workstations and one multipurpose server that also acts as a DHCP server. Your ISP limits you to one static IP address. You give the IP address of your DHCP server to the ISP. During testing, you find that you cannot access the Internet from the workstations. You ping all the devices inside the DHCP server successfully.

The network configuration of one of your workstations is shown in the exhibit:

Windows IP Configuration

Host Name : emc454w11

DNS Servers:

Node Type : Broadcast

NetBIOS Scope ID:

IP Routing Enabled : No

WINS Proxy Enabled : No

NetBIOS Resolution Uses DNS . : Yes
Ethernet adapter:
Description : Fast Ethernet+56K Modem Card
Physical Address : 000400B3204A
DHCP Enabled : Yes
IP Address : 192.168.10.23
Subnet Mask : 255.255.255.0
Default Gateway:
DHCP Server : 192.168.10.1
Primary WINS Server:
Secondary WINS Server:
Lease Obtained: 03 06 11:23:12 AM
Lease Expires: 03 09 11:23:12 AM
What is the probable cause of the problem?
A.The DHCP server is down
B.The Subnet mask is incorrect
C.The DNS server is not set on the workstations
D.The DNS server is not set on the DHCP server
E.The Default gateway is not set on the workstations

Answer: E

The exhibit shows that no default gateway has been configured. A default gateway is used to reach beyond the local network, to access Internet for example.

QUESTION 357

You work as a network administrator for your company. The company has five telecommuters that connect to the company's network via a RAS server. One of the telecommuters complains that she cannot connect to the Internet with her Windows Laptop but she is able to log in to the server running IPX/SPX. The IP address of her laptop is 0.0.0.0.

What is the most likely cause of this problem?

- A.The DNS server is down.
- B.The DHCP server is down.
- C.Her network cable is faulty.
- D.The NetBIOS over TCP/IP has been disabled.

Answer: B

The IP address 0.0.0.0 indicates an IP configuration problem. The DHCP server cannot be reached.

QUESTION 358

You are a network administrator at your company. You plan on adding a DNS server to the network and moving server resources to a new server farm with new addresses. Before adding the DNS server, you use HOSTS files to get to resources by host name.

What would happen once the DNS server is installed?

- A.Users will be able to connect if a DNS server is added to the affected network segments.
- B.Users will be able to connect if a DNS is enabled on the server and the HOSTS file is deleted.

N10-003

- C.Users will be able to connect if a DNS is enabled on the server and you create static NETSTAT entries.
- D.Users will be able to connect if a DNS is enabled on the server and the LMHOSTS file is deleted.

Answer: B

The DNS server will replace thehostsfiles. The old hosts file should be deleted

QUESTION 359

Which of the following pairs up to form an IPX address? (Choose two)

- A.Subnet mask
- B.Header prefix
- C.MAC address
- D.Network address

Answer: C;D

Explanation: An IPX address contains 80 bits, 32 bits for the network address and 48 bits for the MAC address.
Incorrect Answers

- A:TCP/IP uses a subnet mask.
 - B:Header prefixes are not used by IPX.
-

QUESTION 360

Which of the following represents a valid IPv4 address?

- A.129.22.253.1
- B.265.35.15.67
- C.43A6.0000.DA30.0012.00C3.3FA4.0D32.12E2
- D.43A6::DA30:0012:00C3:3FA4:0D32:12E2

Answer: A

Explanation: A valid IPv4 address consists out of four octets, each with a value between 1 and 255.
Incorrect Answers

- B:265 is not a valid octet value
 - C, D:An IP address has only four octets.
-

QUESTION 361

You are installing a new workstation on an IP network segment. The segment uses class C addresses.What would be the default subnet mask for this workstation?

- A.255.255.255.224
- B.255.255.255.0
- C.255.255.224.0
- D.255.255.0.0

Answer: B

Explanation: Class C networks have a 24bit subnet mask of 255.255.255.0.

N10-003

Incorrect Answers

A: This is a 27-bit subnet mask.

C: This is a 19-bit subnet mask.

D: Class B networks have a 16-bit subnet mask of 255.255.0.0.

QUESTION 362

On IP networks, what term is used to refer to a device with a logical address?

A. host

B. peer

C. client

D. server

Answer: A

Explanation: Any device that has a logical address, an IP address, is referred to as a host.

Incorrect Answers

B: A peer device is a corresponding device. For example all computers in a peer network are considered equal.

C: Clients are just an example of IP host.

D: Servers are just an example of IP host.

QUESTION 363

You are the network technician at your company. The network segment in a remote office is IP network 192.168.100.0/24 and includes a router with the IP address set to 168.100.0.1.

What is a valid IP address for a computer on this network?

A. 192.168.1.1

B. 192.167.100.10

C. 192.168.100.254

D. 192.168.100.255

Answer: C

Any valid IP address on the 192.168.100.0/24 must have the format 192.168.100.xxx since the subnet mask is 24 bits.

We cannot use the 192.168.100.255 address since it is the broadcasts address. The 192.168.100.254 address can be used however.

QUESTION 364

On an IPv4 network, what does the network address 255.255.255.255 signify?

A. A subnet mask

B. A unicast address

C. A broadcast address

D. A multicast address

Answer: C

255.255.255.255 is the broadcast address for all nodes on the same network.

Note: 255.255.255.255 is not a subnet mask as it uses all the bits. Thus no bits are left for the host addresses.

QUESTION 365

What protocol would you use if you were implementing a network address scheme based on network classes?

- A. TCP/IP
- B. IPX/SPX
- C. NetBEUI
- D. AppleTalk

Answer: A

TCP/IP has 3 network classes: A, B, C, and D.

QUESTION 366

You are a network administrator at Certkiller, Inc. You need to determine the subnet mask for network B. You are given the following information regarding network B:

1. Is IP network 172.26.0.0/16
 2. IP address of the router for Network B is 172.26.0.1.
- What would the subnet mask for a computer attached to network B be?

- A. 255.0.0.0
- B. 255.224.0.0
- C. 255.255.0.0
- D. 255.255.224.0
- E. 255.255.255.0

Answer: C

A 172.26.0.0/16 network uses a 16-bit network mask with is expressed as 255.255.0.0.

QUESTION 367

Study the Exhibit below carefully:

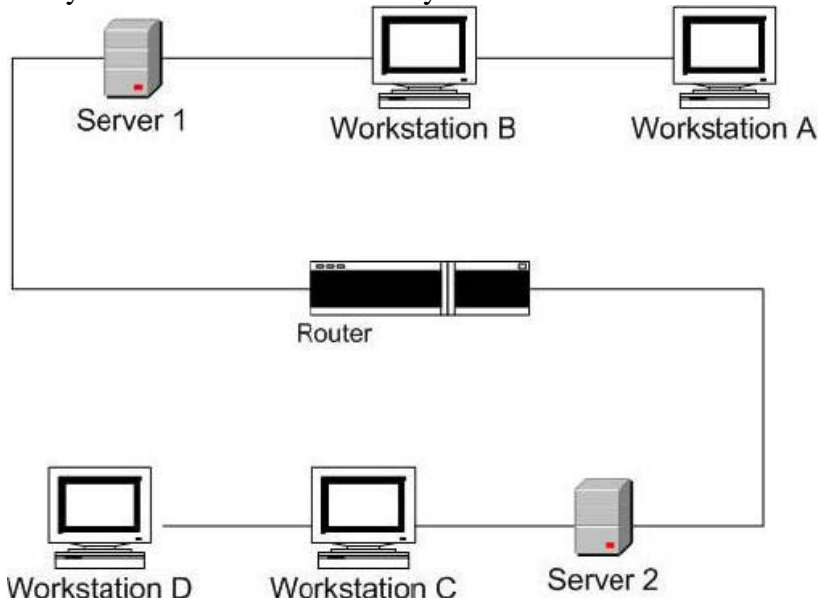

Workstation A is capable of connecting to Server 1, but cannot connect to Server 2. What should you do first to

N10-003

solve

this problem?

- A.Reboot Server 2.
- B.Check the Workstation A gateway address.
- C.Reload Workstation A's operating system.
- D.Check the Workstation B gateway address.

Answer: B

Explanation: Workstation A can access on the local subnet but not resources on the other subnet. The internal interface of the Router should be used as the default gateway. If the default gateway is misconfigured only resources on the local subnet is accessible. We should check the gateway address on Workstation A.

Incorrect Answers

- A:Rebooting the server is a possibletroubleshoot. However, we should check the configuration on the client first.
- C:Reinstalling the operating system should only be used as a last troubleshooting step.
- D:We are troubleshooting Workstation A. not Workstation B.

QUESTION 368

Which of the following represents a Class B IP address?

- A.127.26.36.85
- B.211.39.87.100
- C.89.156.253.10
- D.191.123.59.5
- E.199.236.35.12

Answer: D

Explanation: Class B address are in the 129.0.0.0 through 191.255.255.255 range

Incorrect Answers

- B, E:These are class C addresses since the first octet is in the 192 through 223range.
- A, C:These are a class A address since the first octet is in the 1 through 127 range.

QUESTION 369

You are a network technician at your company. The company has a large network. You want to break up the network into three networks Network

A, Network B, and Network C. You want to configure each network so that it treats the network and node number differently.

What is the process of changing the configuration of Network A, Network B, and Network C so that it treats the network and node number differently?

- A.routing
- B.proxying

- C.switching
- D.subnetting

Answer: D

By subnetting the network into several distinct networks the address is separate into a network part and a node number (called subnet mask and host number when using TCP/IP).

QUESTION 370

You are an IT consultant. A company that has just completed a merger with another small company hires you to link the two separate networks in the Admin Departments of the two companies. Then network in the Admin Department at both companies consists of a single segment.What should you configure to allow nodes on these two local networks to communicate with each other?

- A.A DNS server
- B.A WINS server
- C.A DHCP server
- D.A default gateway

Answer: D

Explanation: To allow communication outside the local subnet you must specify a default gateway. The default gateway provides access to resources outside the local subnet.

QUESTION 371

When a client sends a packet to a host that is not on the client's subnet, where is the packet sent to?

- A.Local host
- B.Default gateway
- C.The nearest bridge
- D.Nowhere, because the packet is discarded

Answer: B

The default gateway is used to reach remote hosts located outside the local subnet.

QUESTION 372

Which type of network makes use of IP addresses created by the local Network Administrator?

- A.Public network
- B.ARCNet network
- C.Private network
- D.Internet network

Answer: C

N10-003

Explanation: The local network administrator can use IP addresses from the private IP address range.

Incorrect Answers

B:ARCNet is just a name of a predecessor to Ethernet. ARCNet networks can use both private and public addresses.

A, D:Internet networked LANs or public networks must use registered IP addresses.

QUESTION 373

Which of the following types of network uses network addresses that are assigned by the IANA?

- A.A POTS network
- B.A public network
- C.A private network
- D.An ARCNet network

Answer: B

Public networks use public addresses. These must be acquired through IANA.

QUESTION 374

Place an address next to its associated class.

Term	Definition
<place here>	Class A
<place here>	Class B
<place here>	Class C

Addresses to be moved. Not all addresses will be used.

199.105.192.99 127.0.0.1 122.47.13.19

244.0.0.2 162.138.149.2

Answer:

N10-003

Place an address next to its associated class.

Term	Definition
122.47.13.19	Class A
162.138.149.2	Class B
199.105.192.39	Class C

Addresses to be moved. Not all addresses will be used.

127.0.0.1

244.0.0.2

Explanation:

*Class A networks use a default subnet mask of 255.0.0.0 and have 0-126 as their first octet.

*Class B networks use a default subnet mask of 255.255.0.0 and have 128-191 as their first octet.

*Class C networks use a default subnet mask of 255.255.255.0 and have 192-223 as their first octet.

QUESTION 375

In a case where you are connecting a UNIX/Linux workstation to an outside WAN server, which two steps are necessary to properly configure eth0? (Choose two)

- A.setting netmask
- B.setting gateway
- C.running ifup eth0
- D.setting MAC address

Answer: B;C

Explanation: In order to access resources outside the local network the default gateway must be properly configured.

We should also configure the interface

Incorrect Answers

A:The netmask does not need reconfiguration

D:MAC addresses are physical addresses, not logical addressing. Physical addresses cannot be changed or reconfigured.

QUESTION 376

Of the following which makes use of TDM (Time Division Multiplexing)?

- A.Broadband
- B.Baseband
- C.Wideband

Answer: B

N10-003

Explanation: Baseband technologies can use time division multiplexing (TDM) to transmit data signals more efficiently.

In TDM, signals are allowed to use the network medium for a certain block of time. When this block of time has

expired, then the signal must give up the network medium to another signal.

Incorrect Answers

A: Broadband use frequency division multiplexing (FDM) to transmit several signals concurrently.

C: Wideband does not use FDM.

QUESTION 377

What are the features of PSTN? (Choose all that apply.)

A. Inexpensive.

B. Readily available.

C. Easy to configure.

D. Transfer rates of 64 Kbps.

Answer: A, B, C

Explanation:

A Public Switched Telephone Network (PSTN) makes use of telephone lines. It is this readily available. It is also

inexpensive and easily configurable.

Incorrect Answers

D: The Public Switched Telephone Network (PSTN) typically supports speeds of maximum 56 Kbps not 64 Kbps.

QUESTION 378

Which of the following technologies uses Frequency Division Multiplexing (FDM)?

A. Baseband

B. Wideband

C. Broadband

D. Narrowband

Answer: C

Explanation: In broadband, multiple signals can be transmitted on the same cable simultaneously by means of frequency

division multiplexing (FDM).

Incorrect Answers

A: Baseband only use one signal at a time. Baseband can use time division multiplexing (TDM).

B: Wideband does not use FDM. Wideband is a transmission medium or channel that has a wider bandwidth than one

voice channel (with a carrier wave of a certain modulated frequency). This term is usually contrasted with narrowband.

B: Narrowband does not use FDM. Narrowband is a transmission medium or channel that has a narrower

bandwidth
than one voice channel.

QUESTION 379

You are a network administrator at your company. Your company's network consists of multiple locations in different states. The various locations are connected via WAN links. Sensitive data is often transferred across the WAN links.

You want to secure the data. Which of the following is the best approach?

- A. Use ISDN
- B. Encrypt Data
- C. Share level security
- D. Password protect data

Answer: B

Explanation: Anyone could have access to the WAN, so the data must be secured by the means of encryption

Incorrect Answers

A: ISDN does not provide any security.

C: Share level

security only secures local resources. It does not secure anything transferred on the WAN.

D: Password protected

data would be unprotected when it is transferred on the WAN.

QUESTION 380

Which of the following broadband connections provides the fastest connectivity?

- A. T1
- B. T3
- C. DS0
- D. BRI ISDN

Answer: B

Explanation: T3, also known as DS3, access is 224x the speed of T1 access, making T3s the ultimate in Internet access for businesses. Maximum T3 speed is 45 Mbps

Incorrect Answers

A: T1 offers speeds up to 1.544 Mbps. T1 is also known as DS1.

C: Digital Service level 0 is the next step up from analog private lines. Each DS0 channel supports transmission rates

from 2.4 Kbps to 64 Kbps.

D: BRI ISDN has a maximum speed of 128 Kbps

QUESTION 381

You are a network administrator at your company. Your company has a large network that is spread across 15 locations in multiple states. The locations are connected via WAN links. You receive a call from a user

N10-003

who complains that she cannot access the local printer. You need to determine the extent of the problem. Which questions can be eliminated? (Choose all that apply.)

- A. Is the problem enterprisewide?
- B. Is the problem easy to duplicate?
- C. Is the problem across the WAN?
- D. Is the problem isolated to the user's workstation?

Answer: A, C

The problem only involves the local network. It is not a WAN or enterprise problem.

QUESTION 382

You are the network administrator at your company. You are in the process of setting up a data link between two offices of your company. There are 18 employees located in each office. Your main concerns are the speed of the connections, the reliability of transferring of data, and the cost.

Which solution should you implement?

- A. Connect an ISDN circuit to each workstation in both locations
- B. Place a modem on a server in each office to connect to each other
- C. Use an ISDN circuit connected to a dedicated server in each building
- D. Have each workstation at both locations use a modem to connect to the opposite office.

Answer: C

ISDN provides better speed, connection time, and reliability compared to a modem. We only need one ISDN circuit, not several.

QUESTION 383

You are a network administrator at your company. At 10 A.M.

, a new employee started working for the company. New telephone and network connections were installed to accommodate the new employee. Now no users in the office can connect to the WAN. All users were able to connect to the WAN earlier this morning, before the new employee was installed. You gather detailed information about the problem from the office and determine that no other WAN connections are involved.

What is your next troubleshooting step?

- A. Formulate a solution.
- B. Establish the symptoms
- C. Identify the affected area.
- D. Establish what has changed.
- E. Establish the probable cause of the problem.

Answer: C

After establishing the symptoms we should identify the affected area.

One possible order, within CompTIA guidelines, when troubleshooting a network is:

1. Establish the symptoms
2. Identify the affected area.
3. Establish what has changed.
4. Establish the probable cause of the problem.
5. Formulate a solution.

6. Implement a solution.
 7. Test the solution.
 8. Recognize potential effects of the solution of the solution.
 9. Document the problem and solution.
 10. Give feedback to the users.
-

QUESTION 384

You want to implement Network Attached Storage on your network. Which protocols can you use with NAS? (Choose all that apply.)

- A. IPX
- B. ATM
- C. TCP/IP
- D. Frame Relay

Answer: A, C

NAS supports IPX and TCP/IP.

ATM and frame relay are not protocols supported by NAS:

QUESTION 385

You are the administrator of the Certkiller Windows NT network and have been requested to add 20 users for RAS connectivity.

In which of the following ways would you install the software on the NT server?

- A. My Computer ->Control Panel ->Services ->Add ->Remote Access Services
- A. My Computer ->Control Panel ->Network ->Services ->Add ->Remote Access Services
- B. My Computer ->Control Panel ->Services ->Protocol ->Add ->Remote Access Services
- C. My Computer ->Control Panel ->Network ->Protocol ->Add ->Remote Access Services

Answer: B

Explanation: Procedure:

1. Double click: My Computer
2. Double click: Control Panel
3. Double click: Network
4. Click on: Services Tab and Click Add... button

N10-003

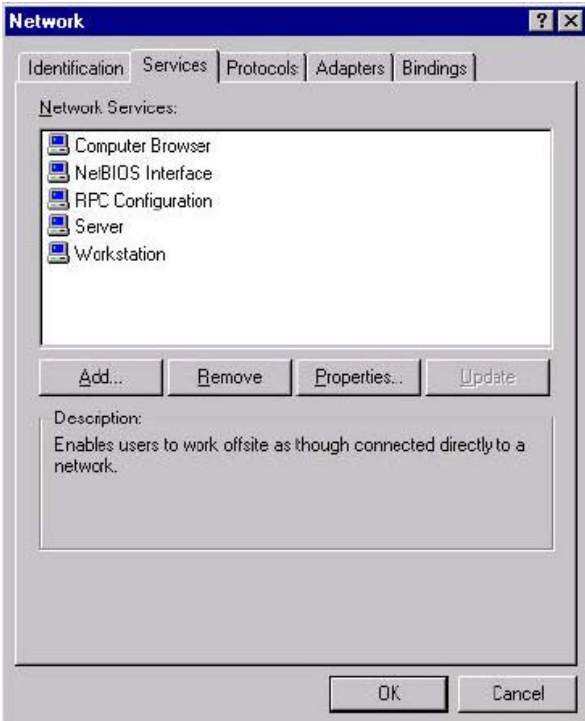

From the Network Service, select Remote Access Service and click on OK button

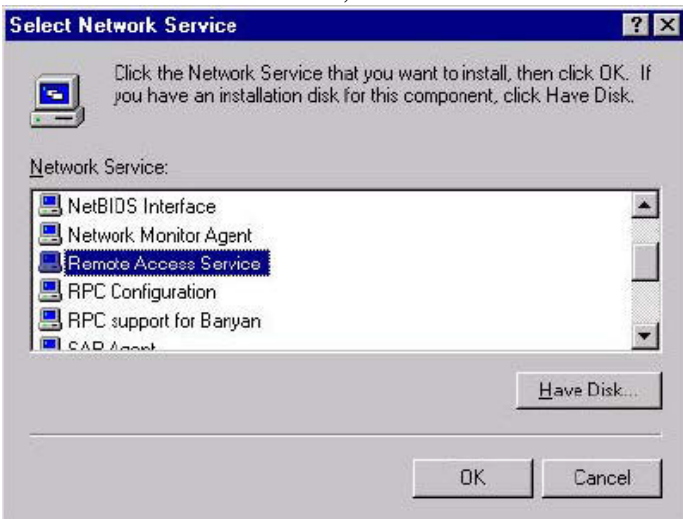

A Window appear as shown below and click Yes to proceed.



Select the correct Modem Driver at the RAS Capable Devices and click on OK

N10-003

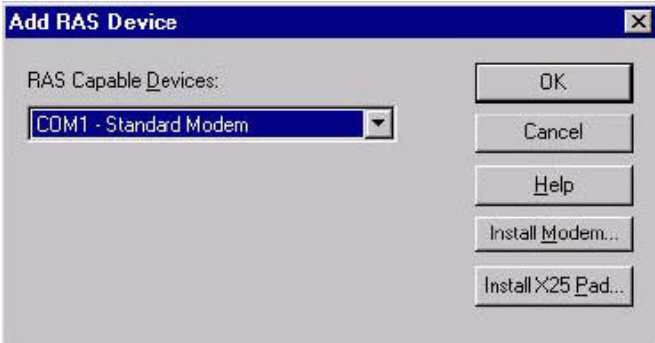

Click on Configure... button to proceed

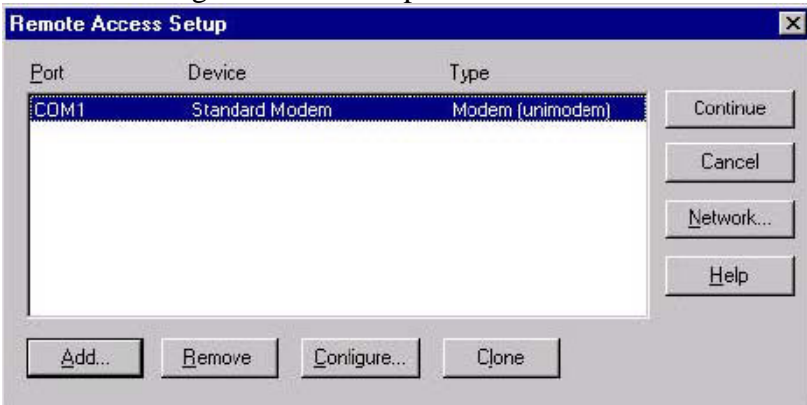

Select Dial out only at the Port Usage and Click OK

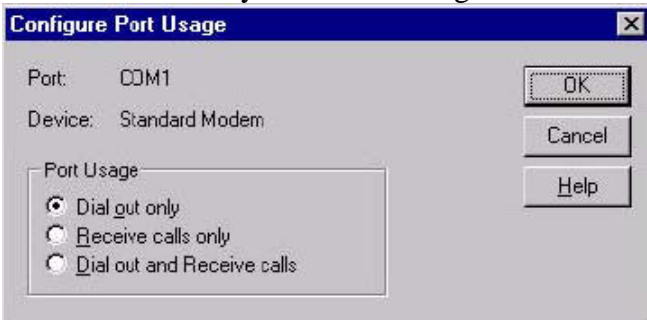

Back to Remote Access Setup window, click on Continue button
Click on OK button to complete the installation

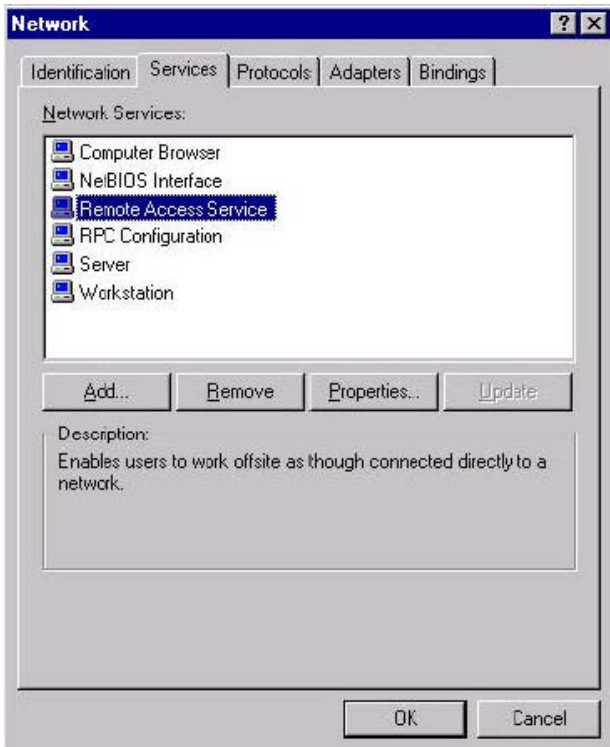

You have successfully installed Remote Access Service into your Windows NT.

QUESTION 386

You configured your Windows 98 workstation with a dial-up SLIP connection to an ISP. You are able to the ISP but you cannot access the Internet.

What should you do to resolve this problem?

- A. Verify your userID
- B. Verify your password
- C. Verify the phone number of the ISP
- D. Change the protocol from SLIP to PPP

Answer: D

SLIP is an older remote access protocol. PPP and PPTP are the preferred remote access protocols.

QUESTION 387

You work as an IT consultant. You are currently working for a client that asked you to implement a solution that provides for secure authentication and encryption to a private network for his client machine. The client machine needs to connect to a NetWare server inside the private network.

Which protocols should implement to provide this functionality? (Choose all that apply.)

- A. TFTP
- B. PPTP
- C. SMTP
- D. SNMP
- E. TCP/IP

Answer: B, E

N10-003

First we must use a generic network protocol, for example TCP/IP, and then a remote protocol as PPTP. SMTP is for email, TFTP is used for file transfers, and SNMP is used to monitor network traffic.

QUESTION 388

Which of the following methods encapsulates standard PPP by means of a variety of media?

- A.IPsec
- B.SSL
- C.L2TP
- D.Kerberos

Answer: C

Explanation: Layer Two Tunneling Protocol (L2TP) is able to encapsulate standard PPP.

Incorrect Answers

- A:IPSec is used to encrypt IP traffic.
 - B:SSL is used to secure HTTP traffic.
 - D:Kerberos is an authentication protocol.
-

QUESTION 389

You are building a small Windows 2000 network. You have installed 16 Windows 2000 Professional workstations and one Windows 2000 Server machine. What is the default LAN network access security that will be used on this network?

- A.SSL
- B.L2TP
- C.IPsec
- D.Kerberos

Answer: D

Windows 2000 uses the Kerberos protocol for access security.

QUESTION 390

You are a network administrator at your company. Your company's network includes Windows NT, Windows 2000

Server, NetWare, and UNIX servers, as well as Apple, Linux and Windows 98 workstations. You need to implement

an authentication solution with an authorization server for this network. What solution can you implement?

- A.SSL
- B.IPsec
- C.L2TP
- D.Kerberos

Answer: D

The Kerberos security system uses security tickets.

QUESTION 391

Which server operating system natively makes use of domain servers?

- A.Linux
- B.NetWare 5.0
- C.MAC OS 8.0
- D.Windows 2000

Answer: A

Explanation: Domain servers are used in the context of DNS. UNIX and LINUX natively use DNS for name resolution.

Incorrect Answers

B:NetWare do not use domain users by default.

C:MacOS uses Apple proprietary name resolution methods. Domain servers are not used.

D:Windows 2000 can be installed without DNS support.

QUESTION 392

You instructed the Certkiller Trainee to connect a Windows NT machine to a NetWare 5 server. Which of the following

will you advise the trainee to use? (Select two)

- A.TCP/IP
- B.NetWare
- C.NetBEUI
- D.Client for NetWare Networks.

Answer: A, D

Explanation:

A:Netware 5 uses TCP/IP natively.

D:Would also need Client for NetWare Networks service.

Incorrect Answers:

B:Netware 5 uses TCP/IP natively, Netware versions 4 and below use SPX/IPX.

C:NetBEUI are not native protocols of NetWare 5.

QUESTION 393

A user is capable of accessing the Internet and departmental drives, but is cannot view the home directory. You verify

that the user directory is located at the appropriate server location?

What is the most likely cause?

- A.The user is not logged in to the domain.
- B.The directory location has been unmapped in the user's profile.
- C.The user has logged on to the network with the wrong password.
- D.The network cable between the user's workstation and the flex point is bad.

Answer: B

ExplanationThe user has access to the local network as he can access the departmental drives, which most likely

are part of the network. Furthermore, the problem is just that he can't see that home directory. We just need to remap it or browse for it.

Incorrect Answers

The user is already accessing network resources, so he is already logged in to the domain with correct password. There is no network connectivity problem.

QUESTION 394

The Certkiller trainee technician wants to know what the typical functions of the client in the client/server environment is.

What will your reply be? (Choose three)

- A. It formats a request for data.
- B. It performs a search for the data.
- C. It displays data results to the user.
- D. It produces requested information.
- E. It presents an interface to the user.

Answer: A, C, E.

Explanation:

A: The client is used to format the data request.

C: The client displays data to the end user.

E: The client presents and interfaces to the user.

Incorrect Answers

B: The server performs the search for data.

D: The server produces requested information.

QUESTION 395

You are building a NetWare 4.xx network. What directory service would you use on this network?

- A. SPX
- B. DNS
- C. DFS
- D. NDS

Answer: D

Explanation: NetWare 4.0, released in 1993, was the first version to include NDS, which at that time stood for NetWare Directory Services, but is now Novell Directory Services.

Incorrect Answers

A: IPX/SPX is a network protocol of Novell, not a directory service.

B: DNS is used for domain name resolution.

C: Distributed File System (DFS) is a file service, not a directory service. DFS enables shared drives on servers all over the network to appear to clients as a single combined share.

QUESTION 396

You are hired as the network technician at a new company. The company has 10 Windows NT servers, 6 UNIX servers, 1 Novell 5 server, and 120 Windows 95 workstations. You need to implement a communication protocol that will connect to all the servers.

Which protocol should you use?

- A.IP
- B.DLC
- C.NWLink
- D.NetBEUI

Answer: A

Explanation: Novell 5 supports TCP/IP natively. UNIX use TCP/IP. Windows 95 and Windows NT can be configured for TCP/IP.

Incorrect Answers

B:DLC is mainly used by IBM mainframes and some HP printers.

C:NWLink is Microsoft's implementation of IPX/SPX: IPX/SPX is not supported by UNIX computers.

D:NetBEUI is not supported by UNIX computers.

QUESTION 397

You work as a network administrator for your company. Your company has a Novell NetWare 5.1 server. In install a new Windows 98 workstation and connect it to the NetWare server. You verify that the workstation can successfully connect to the server.

You now need the workstation to authenticate to the server. What should you do? (Choose all that apply.)

- A.Configure the tree
- B.Configure the context
- C.Install the Novell NetWare client
- D.Install File and Printer Sharing for NetWare Networks.

Answer: A, B, C

We should install the Novell NetWare client and configure the tree and a context.

It is not necessary to install File and Printer Sharing for NetWare Networks to be able to logon to the NetWare server.

QUESTION 398

Which two pieces of information are required when logging on to a Windows 2000 Server? (Choose two.)

- A.password
- B.username
- C.IP address
- D.MAC address

Answer: A, B

To logon to a Windows NT Server the user must provide username and password.

QUESTION 399

You are a network technician at a large company. Your company has Linux, Windows NT, Windows CE, NetWare 5, and Palm OS machines. You want to install a NetWare print server.

Which of these machines can function as a NetWare print server? (Choose all that apply.)

- A. Linux
- B. Palm OS
- C. NetWare 5
- D. Windows CE
- E. Windows NT

Answer: A, C, E

Linux, NetWare 5 and Windows NT can all be used for NetWare printers.

Palm OS and Windows CE are used for portable palmtop computer systems.

QUESTION 400

You work as the network administrator for your company. The company has a NetWare 3.11 server and a UNIX server. You purchase a new client machine.

Which protocols should you implement to allow the client machine needs to communicate with both the NetWare 3.11 server and the UNIX system?

- A. CDP
- B. TCP/IP
- C. NetBEUI
- D. IPX/SPX
- E. Banyan VINES

Answer: B, D

NetWare 3.11 natively supports with the IPX/SPX protocol.

UNIX and Linux systems use the TCP/IP protocol.

QUESTION 401

Certkiller has just migrated its Novel NetWare server to Windows NT. Due to the fact that you are more familiar with the IPX/SPX protocol, you choose to use it instead of TCP/IP. You connect the network to the Internet through an ISDN connection.

Which limitations are you bound to encounter?

- A. You must install TCP/IP to access the Internet.
- B. You must install NetBEUI to reduce your broadcast overhead and to access the Internet.
- C. IPX/SPX is not a routable protocol and will not allow your network to access the Internet.
- D. None. IPX/SPX works well in an Internet environment.

Answer: A

Explanation: TCP/IP is required for Internet access.

QUESTION 402

You need to implement a name resolution technique for a UNIX host. Which name resolution technique should you use?

- A.DNS
- B.DHCP
- C.Proxy
- D.LMHOSTS

Answer: A

UNIX use TCP/IP and host names. DNS is used for host to IP address resolution.

DHCP (automatic IP configuration of clients) or Proxy server (internet access) do not apply here.

LMHOSTS files are used for NetBIOS (not host names) to IP address resolution.

QUESTION 403

Which of the following permissions are valid on a Unix/Linux file system? (Choose all that apply)

- A.read
- B.write
- C.change
- D.execute
- E.take ownership

Answer: A, B, D

The UNIX/Linux file system have read, write and execute (but not change and take ownership)filepermissions.

QUESTION 404

Which of the following statements describes a VLAN?

- A.An Ethernet network that uses PPP encapsulation.
- B.A conceptual LAN that is created in CAD environment.
- C.A group of ports that behaves as an independent switch.
- D.A collection of computers that utilizes an experimental protocol.

Answer: C

Explanation: A VLAN or virtuellanis nothing more than a LAN that has been defined logically. One implementation is

portbased

where a group of ports that behaves as an independent switch.

Incorrect Answers

A:VLANs are not related to PPP encapsulation.

B:VLANs are not specific for CAD environments.

D:VLANs are not related to experimental protocols..

QUESTION 405

You are the network technician of a small office/home office network. The network has grown recently. You want to separate the network into two separate networks but you have only one switch.

How would you manage to separate the network?

- A.Enable SNMP on the switch.
- B.Enable SNTP on the switch.
- C.Implement QoS on the switch.
- D.Implement VLANs on the switch.

Answer: D

Virtual local area networks (VLANs) can be implemented within a switch.

QUESTION 406

To what do devices within the same VLAN always belong to?

- A.The same switch.
- B.A broadcast domain.
- C.The same CSDU/DSU.
- D.A Windows NT domain.

Answer: B

Virtual network within a switch belongs to the same broadcast domain

QUESTION 407

You work as an IT consultant. You are currently working for a client that has a 24port switch. The client

wants to use 12 ports for an IPbased network and 12 ports for an IPXbased network. These two networks will not talk to each other.

What method should you implement on the switch to achieve this functionality?

- A.SMTP
- B.VLANs
- C.Routing
- D.A RMON probe

Answer: B

We implement two virtual networks (VLANs) with the switch.

QUESTION 408

In what location will you find the file system in a Network Attached Storage (NAS) system?

- A.At the router.
- B.At the switch.
- C.At each client.
- D.At the storage device.

Answer: D

N10-003

Explanation: NAS challenges the traditional file server approach by creating systems designed specifically for data storage. A single hardware device, often called the NAS box or NAS head, acts as the interface between the NAS and network clients. The NAS devices require no monitor, keyboard or mouse.

Incorrect Answers

A:A router is used for routing data throughout a network.

B:A switch only forwards data.

C:Files are not stored at the clients.

Note:Clients generally access a NAS over an Ethernet connection. The NAS appears on the network as a single "node" that is the IP address of the head device.

QUESTION 409

Which of the following drive technologies does Network Attached Storage (NAS) make use of? (Choose two)

A.IDE

B.DMA

C.LUN

D.SCSI

Answer: A, D

Explanation: IDE and SCSI are drive technologies.

Incorrect Answers

B:Direct Memory Access (DMA) is not a drive technology.

C:LUN is part of SCSI address, but it not a drive technology.

QUESTION 410

Which RAID level does "Mirroring" make use of?

A.2

B.1

C.3

D.4

Answer: B

Explanation: Mirroring is also known as RAID1.

QUESTION 411

In a situation where you have three hard disks with capacities of 200 MB, 400 MB, and 500 MB, which of the following storage technologies would allow the largest contiguous space for data?

A.volume

A.striping

B.partition

C.mirroring

N10-003

Answer: B

Explanation: Disk striping, RAID 1, would allow 1100MB of storage space. All available space could be used.

Incorrect Answers

A:A volume could ordinarily not span several disks.

C:A partition cannot span several disk. It must be contained on a single physical disk.

D:Mirroring could only use two hard disks. Furthermore, mirroring provided a disk utilization of only 50%

QUESTION 412

You want to implement Network Attached Storage on your network. Which application protocols can you use with

NAS? (Choose all that apply.)

A.NFS

B.EMI

C.SMB

D.ATM

E.HDLC

Answer: A, C

NAS can use the Network File System(NFS) or Server Message Block (SMB)

QUESTION 413

For what reason would you implement fault tolerance?

A.The efficient use of network bandwidth.

B.The elimination of a single point of failure.

C.The ability to restore data after a disk crash.

D.The ability to distribute CPU load across multiple servers.

Answer: B

The purpose of fault tolerance is to eliminate a single point of failure.

QUESTION 414

There is always the concern that users will download viruses when a network is connected to the Internet. What can

you do to protect the systems?

A.Install virus protection on each workstation

B.Install a network virus protection suite

C.Install a firewall

D.Install a proxy

Answer: B

Explanation: A network protection suite provides network wide antivirus protection and keeps the installation,

administration and monitoring effort to a minimum. This is achieved by the centralized virus protection suite.

Incorrect Answers

N10-003

A:It could be a daunting administrative task to install virus protection on each workstation. Furthermore, it would be

less easy to administer and monitor such a solution.

C:A firewall provides protection at port, IP address, or protocol level. A firewall cannot stop viruses however.

D:A proxy provides better network performance, but is not capable of stopping viruses.

QUESTION 415

Which of the following backup methods can be combined with differential backup?

A.Full backup

B.Incremental backup

C.Comparative backup

D.Decremental backup

Answer: A

Explanation: First we must perform a full backup, and then we are able to perform differential backups.

Incorrect Answers

B:Differential backups require that a full backup has been performed.

C:There is no such thing as a comparative backup.

D:There is no such thing as a decremental backup.

QUESTION 416

You have installed a new anti-virus program on all the computers in your network. Later, you installed and configure a

RAID controller on one of your servers. You are now experiencing system crashes throughout the network.

What should you do to resolve this problem?

A.Disable the RAID controller.

B.Uninstall the anti-virus program.

C.Install the latest anti-virus update from the vendor.

D.Check the anti-virus vendor for system patches or service packs.

Answer: D

QUESTION 417

You have implemented as backup strategy using a tape drive. You now want to perform a backup that will clear the

archive attribute. Which backup methods can you use? (Choose all that apply.)

A.Full

B.Sequential

C.Differential

D.Incremental

Answer: A, D

Explanation:

A:A full backup backs up all files and clears the archive attribute of each file that has been backed up.

N10-003

D:An incremental backup backs up all files that have changed since the last incremental or full backup was performed.

Incorrect Answers

B:Sequential backup refers how data is written to the backup media. It does not refer of whether the archive bit is cleared or not.

C:A differential backup backs up all files that have changed since the last full backup, but it does not clear the archive bit of those files.

QUESTION 418

You are the network administrator at your company. You are designing a backup strategy for your company's file server. The file server currently holds 40 GB of data. The CEO of your company instructs you to run backups only after business hours to avoid impacting network performance. Your company is open for regular business Monday to Friday from 8 a.m. to 5 p.m. You purchase a 50 GB tape drive with a data transfer rate of 2.1 GB per hour.

On which days can you perform full backups? (Choose all that apply.)

A.Monday

B.Tuesday

C.Wednesday

D.Thursday

E.Friday

Answer: E

Explanation: 2.1 GB per hour and 40 GB to backup make the duration of the backup process 19.1 hours long. The

backup should take place during the weekends, starting Friday night.

Incorrect Answers

A,B,C There are only 15 non-business hours between 5 p.m. and 8 a.m. The 19.1 hour backup process must not be started Monday to Thursday.

QUESTION 419

What is the purpose of disaster recovery?

A.To rebuild the structure area around the server farm

B.To recover all users data/software for all workstations

C.To recover various non-job-related files from users and workstations

D.To recover the pertinent software applications and data to continue business

Answer: D

The goal of disaster recovery is to be able recover data and continue the business.

QUESTION 420

You are a network technician at Certkiller .com. Following a hard disk drive on your file server recently failed resulting in

a complete loss of data. You want to prevent this from reoccurring.

N10-003

You decide to implement a disaster recovery strategy. Which methods can implement for disaster recovery?
(Choose all that apply.)

- A.A honeypot
- B.Tape backup
- C.Mirrored servers
- D.A remote hot site
- E.Uninterruptible power supply

Answer: B, D

To recover from a disaster we should make regular backups (to tape for example) and keep some of the backup media at an offsite

location. Another disaster recovery solution is to use a remote hot site.

Note: Ordinarily the primary site of operation is the hot site. For backup reasons a remote cold site can be implemented.

The cold site should include appropriate equipment and resources so that it can become a remote hot site if the local hot site gets hit by a disaster.

QUESTION 421

You have implemented a backup link for your network. The network is shown in the following exhibit:

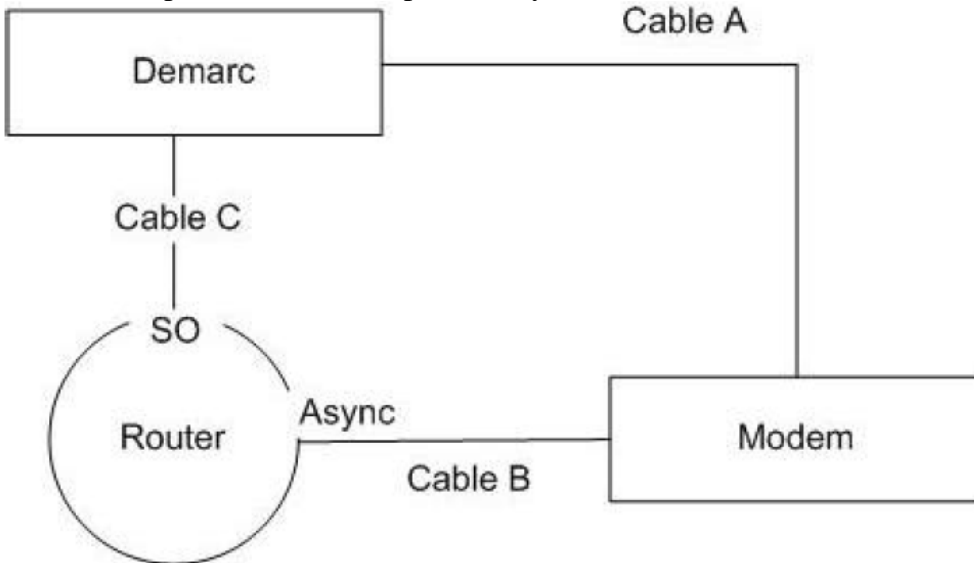

The telco has tested clean to the Demarc. The modem responds to a command to go off-hook, but you cannot detect a dial tone.

Which component is a possible for this dial back-up failure?

- A.The router
- B.Cable C
- C.Cable A
- D.Cable B

Answer: A(?)

A problem with the router seems most likely.

QUESTION 422

What is the worst case scenario for discovering that your weekly full backup job did not complete?

- A. While you are testing your backup system
- B. While trying to recover a new program that you just installed on the server
- C. When a user requests that you restore a file that was accidentally deleted the day before
- D. When the main server crashes and you need to perform a full system disaster recovery restore

Answer: D

The worst case scenario would be if the main server crashes.

QUESTION 423

You work as a network administrator. Your network recently suffered down time when one of your network servers as failed. You are asked ensure fault tolerance for the network. Which three methods can you use to accomplish this?

(Choose three.)

- A. tape backup
- B. mirrored servers
- C. RAID disk storage
- D. off-site data archive
- E. uninterruptible power supply (UPS)

Answer: A, B, C

Fault tolerance can be achieved with

1. backup to other media (tape for example)
2. mirrored servers
3. RAID (for example RAID-5) disks which stores parity bits for fault tolerance

An off-site data archive is used for disaster recovery, not for fault tolerance.

UPS are used to keep the system up in the event of a power failure. It does not provide fault tolerance.

QUESTION 424

You work as a network administrator for Certkiller , Inc. Your backup strategy consists of weekly backups of your network servers. Where should you store the tapes, for disaster recovery?

- A. In the CIO's office
- B. In the Network administrator's desk
- C. In a locked safe at an onsite location
- D. In a locked safe at on offsite location

Answer: D

It is best to keep the tapes offsite in case of theft or fire for example.

QUESTION 425

You work as a network administrator at your company. A user named Joe complains that he cannot access files on the network. You check the network properties for Joe's workstation. The results are displayed in the exhibit below.

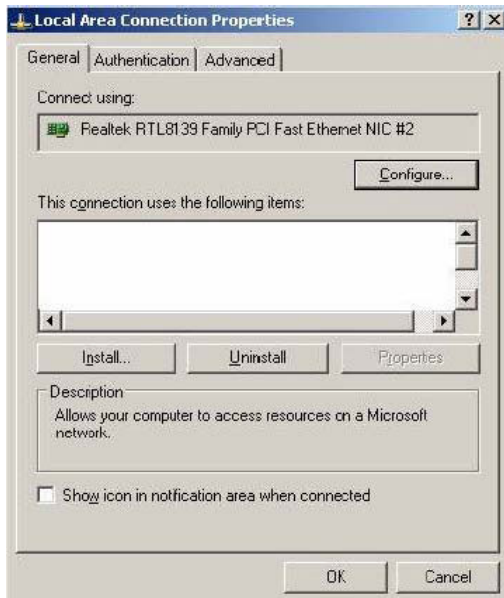

What is the most likely cause of this problem?

- A. A virus
- B. System file corruption
- C. A Windows registry problem
- D. The user has changed the configuration

Answer: D

The user has accidentally removed the installed network components.

QUESTION 426

The new Certkiller trainee technician wants to know which dial-up protocol does not provide addressing, packet type identification, error detection/correction, or compression mechanisms and requires that the device on each end know the other's address. What will your reply be?

- A. PPP
- B. SLIP
- C. POTS
- D. TCP/IP

Answer: B

Explanation: SLIP is an old remote access protocol, which only should to connect to legacy servers.

Incorrect Answers

A: PPP is a better remote access protocol. It supports the features listed in this scenario.

C:POTS stands for Plain Old Telephone System.

D:TCP/IP is a network protocol, not a remote access protocol.

QUESTION 427

A remote user has recently been set up to use a NetWare 4.11 server. The user has previously been able to dial in to

the network to send and receive email

and to access the Internet. The user had dialed in to the network and is able to send and receive email,

but is not able to connect to the server.

Which of the following represents the most likely cause of the problem?

A.The user is not connected to the network.

B.The user's connection is too fast.

C.The user's dialup

connection protocols are not configured properly.

D.The user's modem is not capable of connecting to a NetWare server.

Answer: C

Explanation:

The remote client must be configured with the protocol used by the NetWare server, which most likely is IPX/SPX.

Incorrect Answers

A, B:The user is able to connect to the network and to access the e-mail service.

D:A modem provides remote communication. The type of server is not relevant.

QUESTION 428

You are a network administrator at your company. Your company has a number of telecommuters who dial-up to a RAS server to access the corporate network. Your company hires a new telecommuter name Joe. On Joe's first trip, he complains that he cannot dial-up to the corporate network from his hotel room. Joe unplugged the cable from the telephone and plugged it into the modem but cannot get a dial tone.

What is the cause of this problem?

A.The dial-up server is not responding.

B.The modem does not support digital phone lines.

C.The modem protocols are not configured properly.

D.The dial-up connection protocols are not configured properly.

Answer: B

QUESTION 429

You work as a network administrator at your company. The company's local network has a permanent connection to the Internet. You are concerned about hackers gaining access to the network from the Internet. You want to block all traffic except the traffic that Windows 2000 Server natively supports.

What LAN protocols should you permit?

A.PPP

B.SLIP

N10-003

- C.TCP/IP
- D.NetBIOS
- E.IPX/SPX

Answer: C, E

Windows 2000 Server natively supports TCP/IP; IPX/SPX, NetBEUI etc.

QUESTION 430

You are the IT supervisor at your company. Your company has a Windows NT network that includes 50 client machines configured for DHCP. You instruct a trainee network technician to create dialin connectivity

for the Marketing Department. The trainee installs a new server fitted with a modem in the Marketing Department.

The trainee now wants to configure the modem's services but is unsure where this is done. What should you tell the trainee?

- A.Go to My Computer ->Control Panel ->Services ->Add ->Remote Access Service
- B.Go to My Computer ->Control Panel ->Network ->Services ->Add ->Dial Up Services
- C.Go to Network Neighborhood ->Dial Up Networking ->Services ->Add ->Dial Up Services
- D.Go to Network Neighborhood ->Dial Up Networking ->Network ->Add ->Remote Access Service

Answer: A

We want to allow the Engineering department dial-in access to the server. We must add the Remote Access Service

(not Dial Up services). We install it as a normal service by using the Services Control Panel applet.

QUESTION 431

You are building a new network. You want to implement a protocol that identifies nodes through the use of the MAC

address as part of its address scheme. What protocol should you use?

- A.TCP/IP
- B.IPX/SPX
- C.NetBEUI
- D.AppleTalk

Answer: B

The address of an IPX frame is 80 bits. The network portion of an IPX address is 32 bits long. The host portion of an

IPX address is taken from the station's 48 bit MAC address.

QUESTION 432

You work as a network administrator for your company. You purchase a new Apple workstation that must be able to connect to a NetWare 4.11 server. The workstation is unable to connect to the server, but it is able to connect to the Internet.

What is the possible cause of this problem? (Choose all that apply.)

- A.The server is not running NetBEUI
- B.The server is not running AppleTalk

N10-003

- C.The workstation is not running IPX/SPX
- D.The workstation is not running NetBEUI

Answer: B, C

To communicate the client and the server must use the same protocol. One solution is to install AppleTalk on the server.

The other solution is to install IPX/SPX on the client.

QUESTION 433

You are implementing a Windows 2000 Server as a remote access server that telecommuters can connect to via dial-up.Which communications dial-up protocols should you use to support these dial-up connections? (Choose all that

apply)

- A.PPP
- B.CDP
- C.SLIP
- D.TCP/IP
- E.IPX/SPX

Answer: A, C

Windows 2000 Servers supports PPP (in-coming and out-going traffic), and SLIP (only out-going traffic).

QUESTION 434

What is the function of a firewall?

- A.A firewall helps keeping personnel costs low.
- B.It keeps hardware safe from failure.
- C.That network users are safe.
- D.That the network is safe from outside influence.

Answer: D

Explanation: A firewall is used to control traffic between the local network and the public network, typically Internet. A

firewall configured can be configured to block harmful inbound traffic and thus keep the local network safe from outside influence.

QUESTION 435

The Certkiller network has a permanent connection to the Internet. The local network included a Web server and an SMTP server. As the network administrator you are concerned about the threat of hackers gaining access from the Internet. You decide to set up filtering on the Internet router. However, after you make this change, your users are no longer able to access their external POP3 accounts. What is the most likely cause of the problem?

N10-003

- A. Your DHCP server is down.
- B. Your Internet router is blocking port 25.
- C. Your Internet router is blocking port 110.
- D. Your Web server is filtering mail requests.

Answer: C

Explanation: POP use TCP port 110.

Incorrect Answers

A: DHCP is only used to automate IP configuration. A DHCP server that is down would not affect POP traffic.

B: SMTP use TCP port 25

D: A Web server does not filter mail requests.

QUESTION 436

The Certkiller network has a permanent connection to the Internet for the network. The local network included a Web server and an SMTP server. As the network administrator you are concerned about the threat of hackers gaining access from the Internet. You decide to set up filtering on the Internet router. You have a permanent connection to the Internet for your network.

Your local SMTP server has stopped sending or receiving messages from the Internet, although your local users can still access local and Internet Web servers.

What should predict the cause of the problem is?

- A. Your DHCP server is down.
- B. Your Internet router is blocking port 25.
- C. Your Web server is filtering mail requests.
- D. Your Internet router is blocking port 110.

Answer: B

Explanation: SMTP use TCP port 25.

Incorrect Answers

A: DHCP is only used to automate IP configuration. A DHCP server that is down would not affect SMTP traffic.

C: Web servers are not used for emails.

D: Port 110 is used for POP traffic, not for SMTP traffic.

QUESTION 437

An internal private network is protected by a firewall from the Internet by means of filtering TCP/IP traffic based upon which three parts of a TCP/IP packet? (Choose three.)

- A. port number
- B. DNS lookup order
- C. source IP address
- D. IPX network number

- E.destination IP address
- F.WINS server NetBIOS name

Answer: A, C, E

Explanation: Firewall filtering can be done using

- 1.port numbers (A)
- 2.source addresses (C)
- 3.destination address (E)
- 4.protocol (not listed here)

Incorrect Answers

DNS lookup order, IPX network number and WINS server NetBIOS name are irrelevant for TCP/IP filtering on firewalls.

QUESTION 438

You have built a small peer-to-peer home network. You want to prevent the spread of viruses on your network.

What should you use?

- A.A firewall.
- B.The scandisk utility.
- C.A tape backup drive.
- D.A workstation protection program.

Answer: D

Explanation: A workstation protection program could help stopping the spread of viruses. It should include an antivirus program that is current.

Incorrect Answers

- A:A firewall stops traffic at port and protocol level. It is not used to stop traffic.
- B:The scandisk utility is used to diagnose and fix hard disk problems.
- C:A tape backup drive does not help in stopping the spread of viruses.

QUESTION 439

You have installed a firewall on your company's network. The manager of the Accounting Department wants to know what the security function of a firewall is. What would you tell him?

- A.It does not allow any connections to the server.
- B.It can manage user name and password functions.
- C.It can restrict unauthorized users from accessing sensitive data.
- D.It allows people on the Internet to see just one internal IP address.

Answer: A

Explanation: A firewall is used to restrict traffic. Traffic can be restricted on ports, source address, destination address, or protocol. We can restrict access to a specific server by denying any traffic to the destination address of this

server.

Incorrect Answers

B:User name and passwords functions are not managed by a firewall.

C:A firewall can not distinguish between authorized and nonauthorized users.

D:Network address translation (NAT) hides the local IP addresses from external internet users. Only one address would be public.

QUESTION 440

You are the network administrator at your company. Your company's network includes a Web server and an SMTP server. The network has a permanent connection to the Internet. Because you are concerned about the threat of hackers gaining access from the Internet, you decide to enforce HTTPS on your Web server. After enforcing HTTPS, your Web server is no longer accessible from the Internet, but can still be accessed by your internal network users.

What is the probable cause of this problem?

A.Your DNS server is down.

B.Your Web server address has changed.

C.Your Internet router is blocking port 389.

D.Your Internet router is blocking port 443.

Answer: D

HTTPS (the SSL protocol) use port 443. The router might be blocking this port.

QUESTION 441

What are the primary functions of a firewall? (Choose all that apply.)

A.proxy server

B.packet filtering

C.dynamic routing

D.Network Address Translation

Answer: B, D

Firewalls filter packets.

Firewalls perform Network Address Translation.

Firewalls do not perform dynamic routing.

A proxy server functions like a firewall but firewalls do not function as proxy servers.

QUESTION 442

Proxy servers and firewalls are two mechanisms that can be used to protect a network. What aspect of the network does a proxy protect?

A.system data

B.external users

C.personnel costs

D.from hardware failure

N10-003

Answer: A

A proxy server protects local data from being exposed to external users.

QUESTION 443

You are a network technician at your company. Your company's network has expanded considerably over the last two months. This growth is expected to continue over the next six months. Because of this growth, more client machines

require access to the internet. You are required to accomplish the following:

*Secure the internal network from possible attack from the Internet.

*Limit the number of public IP addresses the company would need to lease.

Which network device allows you to meet both requirements?

A.A hub

B.A bridge

C.A switch

D.A firewall

Answer: D

A firewall provides public to private network security by providing ability to permit or deny ports and protocols. A

firewall can also provide Network Address Translation (NAT) which provides public to private network address translation.

QUESTION 444

You work as a network administrator at your company. The company's local network includes multiple services and has a permanent connection to the Internet. You are concerned about hackers gaining access to Telnet from the Internet. You decide to implement a firewall and want to configure it to block Telnet sessions.

What port must you block on the firewall?

A.TCP 21

B.TCP 23

C.UDP 143

D.UDP 110

E.UDP 6619

Answer: B

Telnet uses TCP port 23.

QUESTION 445

You work as a network administrator at your company. The company's local network includes multiple services and has a permanent connection to the Internet. You are concerned about hackers gaining access to the local network from the Internet. You decide to implement a firewall and configure it to filter ports 100 through 200.

Which service might be affected by the firewall?

A.FTP

B.NTP

- C.HTTP
- D.SMTP

Answer: B
NTP use UDP port 123.

QUESTION 446

For which purposes are firewalls implemented? (Choose two.)

- A.block traffic
- B.permit traffic
- C.cache web pages
- D.cache email

Answer: A, B
A firewall can be used to block or permit traffic depending on port and protocol.

QUESTION 447

Which of the following processes are performed by a proxy server? (Choose three)

- A.Compresses data on the disk storage device.
- B.Enhances security and administrative control.
- C.Acts as an intermediary between an application and the Internet.
- D.Acts as an intermediary between a workstation user and the Internet.

Answer: B, C, D

Explanation:

B:A proxy server allows the administrator to control traffic that goes into and out of the network.

C, D:A proxy server is located between the workstations and the Internet. It acts as an intermediary between applications run on the clients and internet.

Incorrect Answers

A:A proxy server does not store compressed data on disks.

QUESTION 448

There is a security concern at Certkiller since there are many users on the network that access the Internet. What can you use so that only one IP is visible when users connect to the Internet?

- A.HTTP
- B.FTP
- C.Proxy Server
- D.NBT Server

Answer: C

Explanation: A proxy server can implement network address translation (NAT). Private addresses could be used on the network and just a one IP public need to be used.

QUESTION 449

What is the primary purpose of a proxy server?

- A.It protects the Internet from internal network traffic.
- B.It acts as a file on a router that lists which addresses can go where.
- C.It acts as an intermediary that recreates the packets and services of the communication that is trying to get through.
- D.It acts as a type of firewall that manages packet sequence and origin to reduce the chance of hackers hijacking communication sessions.

Answer: D

A proxy server is a kind of buffer between your computer and the Internet resources you are accessing. The data you request come to the proxy first, and only then it transmits the data to you. It acts like in some ways as a firewall and can be used to protect the local network behind it.

QUESTION 450

You want to implement a proxy server on your network. What services does a proxy server provide? (Choose all that apply.)

- A.Cached email
- B.Cached client files
- C.Cached DHCP information
- D.Cached web pages
- E.Cached DNS information

Answer: A, B, D

A proxy server can cache email, client files, or web pages, but not DNS and DHCP information.

QUESTION 451

Which two are used with digital signatures? (Choose two.)

- A.EncryptAPI.
- B.A Certificate Authority.
- C.Complete data encryption.
- D.An Asymmetric Algorithm.

Answer: B, D

Explanation:

B:A certificate authority issues certificates ensuring that the digital signatures are valid.

D:Digital signatures use an asymmetric algorithm. Some data is encrypted and some data is unencrypted.

Incorrect Answers

A:EncryptAPI enables software developer to encrypt data in their applications. It does not apply to digital

signatures.

C:Digital signatures do not provide complete encryption. Public keys are used.

QUESTION 452

Consider the following:

*A TCP/IP network environment with multiple subnets.

*A user connects to a Windows NT server named CORPSERV on its local subnet.

*WINS is NOT in use.

A user is shifted to another subnet. The user is now unable to login to CORPSERV. What is the problem?

A.A HOSTSfile needs to be configured.

B.A LMHOSTS file needs to be configured.

C.A SERVICESfile needs to be configured.

D.A PROTOCOL file needs to be configured.

Answer: B

Explanation: Windows NT use NetBIOS to IP address resolution. This is implemented either through the WINS server or through a LMHOSTS file. Here we would be required to configure a LMHOSTS file.

Incorrect Answers

A:A hosts file maps host name to IP address, but Windows NT required NetBIOS to IP address resolution.

C, D:There are no such things as a services files or a protocol file in Windows.

QUESTION 453

Which of the following provides NetBIOS name to IP address resolution?

A.hosts

B.lmhosts

C.services

D.protocol

Answer: B

Explanation: Almhsts file contains NetBIOS name to IP address mappings.

Incorrect Answers

A:Ahostsfile contains host name to IP address mappings.

C, D:Services or protocol are not related to NetBIOS name resolution.

QUESTION 454

Study the Exhibit below carefully:

```
windows 98 IP Configuration

Host Name . . . . . : DELL #14
DNS Servers . . . . . :
Node Type . . . . . : Broadcast
NetBIOS Scope ID . . . . . :
IP Routing Enabled. . . . . : No
WINS Proxy Enabled. . . . . : No
NetBIOS Resolution Uses DNS. . . . . : No

0 Ethernet adapter :

Description . . . . . : 3Com EtherLink PCI
Physical Address. . . . . : 00-B0-D0-1D-F5-5B
DHCP Enabled . . . . . : Yes
IP Address . . . . . : 169.254.184.57
Subnet Mask . . . . . : 255.255.0.0
Default Gateway . . . . . :
DHCP Server . . . . . : 255.255.255.255
Primary WINS Server. . . . . :
Secondary WINS Server. . . . . :
Lease Obtained . . . . . : 06 07 01 2:16:31 PM
Lease Expires . . . . . :
```

You, the Certkiller technician, are troubleshooting a connectivity problem on a Windows 98 workstation attached to a large Ethernet network. All of the other workstations on this segment are working fine. All of the workstations (regardless of OS) receive their IP addresses from a DHCP server. According to the information in the exhibit, what is a possible problem?

A. Microsoft TCP/IP assigned an IP address in the absence of a DHCP server.
B. NetWare/IP assigned an IP address in the absence of a DHCP server.
C. Microsoft DNS server assigned an IP address in the absence of a DHCP server.
D. An Apple Macintosh G3 server assigned an IP address in the absence of a DHCP server.

Answer: A

Explanation: The workstation is using a IP address in the 169.254.xx.xx range. This is a selfconfigured IP address which is provided by Microsoft's implementation of TCP/IP. These addresses are also known as APIPA addresses.

Incorrect Answers

- B: There is no such thing as NetWare/IP in a Windows environment.
C: DNS servers are only used to resolve host names, they cannot provide IP address configuration.
D: Apple computers are not used to provide IP addresses to Windows clients.

QUESTION 455

What settings on your PC must be set properly if you are to configure TCP/IP to make use of WINS? (Choose two)

- A. Primary WINS Server
B. Scope ID
C. Enable WINS Resolution
D. Secondary WINS Server

Answer: A, C

Explanation:

N10-003

A:We must define at least a primary WINS Server.

C:We must also enable WINS Resolution.

Incorrect Answers

B:ScopeID is not used in WINS. It is a DNS concept.

D:A secondary WINS Server would provide fault tolerance, but is not strictly necessary.

QUESTION 456

The Certkiller trainee technician wants to know which of the following applications is capable of supporting NetBIOS over TCP/IP?

- A.IP
- B.DNS
- C.NFS
- D.WINS
- E.NTFS

Answer: D

Explanation: WINS provides NetBIOS to IP resolution.

Incorrect Answers

A:IP is a protocol not an application.

B:DNS provides host name resolution, not NetBIOS resolution.

C:NFS is Novell's file system.

E:NTFS is the file system of Windows 2000/XP/.NET and later.

QUESTION 457

You want to implement DNS on your network. You need to configure your workstations for DNS resolution. What should you configure on the workstations? (Choose all that apply.)

- A.A host name
- B.A NetBIOS name
- C.The domain name
- D.The IP address of the DNS server

Answer: A, C, D

Explanation:

A:The workstation must have a host name.

C:DNS works in domain namespaces. Therefore, a domain name must be specified.

D:The workstation must be configured with the IP address of a DNS server.

Incorrect Answers

B:DNS does not use NetBIOS names.

QUESTION 458

You want to implement a HOSTS file to map host names to IP addresses. You want to comment out a line in the HOSTS file. What character is used to start a comment line in a HOSTS file?

- A.
- B.\$

- C.*
- D.#

Answer: D

Explanation: # is used for comments in hostsfiles.

QUESTION 459

What command can you use to verify that a WINS server is resolving host names?

- A.arp -r
- B.nbsstat -r
- C.nbtstat -r
- D.nslookup -r

Answer: C

NBTSTAT utility can be used to find connectivity problems between TCP/IP and NetBIOS (WINS resolves NetBIOS names to IP addresses).

The -r parameter of nbtstat stands for resolved. It can give you a quick view of how your system is resolving and registering names.

QUESTION 460

You work as a network technician for your company. You install a new workstation to the company's Windows NT network. However, the new workstation cannot connect to the network. A visual check indicates that the link lights on both the NIC and the switch are lit. You verify that all protocols are installed on the workstation and that the cable is functioning properly. However, a second user complains of a sudden connection problem.

What is the most likely cause?

- A.DNS servers have not been assigned.
- B.WINS servers have not been assigned.
- C.Duplicate IP addresses have been assigned.
- D.The Default gateway is not set on the workstations.

Answer: C

A duplicate IP address, which are not possible on a network, could explain the problem for the single user. The system did work earlier so it cannot be a DNS, WINS or gateway configuration problem.

QUESTION 461

Which of the following can you use to connect with a Unix server using terminal emulation software?

- A.FTP
- B.Telnet
- C.Netscape
- D.Internet Explorer

Answer: B

N10-003

Explanation: Telnet is used for remote login using terminal emulation.

Incorrect Answers

A:FTP is used for file transfers.

C, D:Internet ExplorerOrNetscape cannot be used as terminal emulator (without additional software).

QUESTION 462

AT Certkiller Inc. you have an email server that makes use of SMTP.What can you use to check that it is accepting

requests on port 25?

A.Ping the email server

B.Telnet

C.NETSTAT

D.NBTSTAT

Answer: B

Explanation: We can use telnet to test if a particular port is open.

Incorrect Answers

A:Pingcan only be used to test connectivity, not to test any ports.

C:Netstat is a command-line program that displays information about a TCP/IP computer's current networkconnections

D:Nbtstat.exe is a Windows command-line program that displays information about the NetBIOS over TCP/IP connections.

QUESTION 463

You manage a Windows NT network with five clients.Which two commands will you advise the new Certkiller trainee

to use when instructed to view the routing table of the NT server in a Windows NT network with five clients' environment? (Choose two.)

A.arp

A.ping

B.route

C.tracert

D.netstat

E.nbstat

Answer: C, E

Explanation:

C:The route command displays the routing table.

E:netstat -r displays the routing table, plus the current active connections.

Incorrect Answers

A:arpwould show IP address to MAC address mappings.

B:Pingis used to test network connectivity.

D:Tracert is used to test routes between devices.

F:nbstat show NetBIOS mappings.

QUESTION 464

After you have set up a dialup network using the SLIP protocol, you discover that you are unable to transfer files with

FTP and are experiencing problems connecting to the Internet. Which of the following represents a viable alternative?

A. Installing a proxy with TCP/IP

B. Pinging the local host

C. Pinging the FTP server

D. Changing to PPP

Answer: D

Explanation: SLIP is an old remote access protocol. SLIP should not be used unless a required by older equipment or

software. A possible cause of the problem in this scenario could be a Remote Access Server which does not support

SLIP.

PPP is more modern remote access protocol and is the preferred solution.

Incorrect Answers

A: A proxy would not be necessary in this scenario.

B: Pinging the local host can be used to test if TCP/IP has been installed correctly.

C: We have a connection problem. Pinging the FTP server is not of much use.

QUESTION 465

Your HTTP server has experienced problems. What utility can you use to troubleshoot the HTTP server?

A. TDR

B. PING

C. Telnet

D. NBTSTAT

Answer: C

Explanation: Telnet can be used to connect to a HTTP server. With telnet you can issue local commands on the HTTP

server which could aid you in troubleshooting.

Incorrect Answers

A: A time domain reflectometry (TDR) is used to test network cabling.

B: PING can be used to test connectivity to a server. You could test connectivity to the HTTP server, but this is not

actually troubleshooting the HTTP server.

D: Nbtstat.exe is a Windows commandline

program that displays information about the NetBIOS over TCP/IP

connections that Windows uses when communicating with other Windows computers on the TCP/IP LAN. This

would
not be useful in troubleshooting an HTTP server however.

QUESTION 466

You are troubleshooting a server machine. You want to see what active connections are currently made to the server. What utility should you use?

- A.PING
- B.NBTSTAT
- C.NETSTAT
- D.TRACERT

Answer: C

Explanation: Netstat is a command-line program that displays information about a TCP/IP computer's current network

connections and about the traffic generated by the various TCP/IP protocols.

Incorrect Answers

A:PING is used to test network connectivity.

B:Nbtstat.exe is a Windows utility displays information about the NetBIOS over TCP/IP connections that Windows

uses when communicating with other Windows computers on the TCP/IP LAN.

D:TRACERT is used to trace routes throughout the network.

QUESTION 467

You are trouble shooting communication protocols. Which command would you issue to view the per protocol statistics?

- A.arp -s
- A.nostat -s
- B.netstat -s
- C.ipconfig /all

Answer: C

Explanation:

netstat-s displays detailed network traffic statistics for the IP, ICMP, TCP, and UDP protocols.

```

L:\WINDOWS\System32\cmd.exe
UDP Statistics for IPv4
Datagrams Received   = 158873
No Ports             = 4256
Receive Errors       = 0
Datagrams Sent       = 162549

L:\Documents and Settings\admin>netstat /?

Displays protocol statistics and current TCP/IP network connections.

NETSTAT [-a] [-e] [-n] [-o] [-s] [-p proto] [-r] [interval]

-a          Displays all connections and listening ports.
-e          Displays Ethernet statistics. This may be combined with the -s
           option.
-n          Displays addresses and port numbers in numerical form.
-o          Displays the owning process ID associated with each connection.
-p proto    Shows connections for the protocol specified by proto; proto
           may be any of: TCP, UDP, TCPv6, or UDPv6. If used with the -s
           option to display per-protocol statistics, proto may be any of:
           IP, IPv6, ICMP, ICMPv6, TCP, TCPv6, UDP, or UDPv6.
-r          Displays the routing table.
-s          Displays per-protocol statistics. By default, statistics are
           shown for IP, IPv6, ICMP, ICMPv6, TCP, TCPv6, UDP, and UDPv6;
           the -p option may be used to specify a subset of the default.
interval   Redisplays selected statistics, pausing interval seconds
           between each display. Press CTRL+C to stop redisplaying
           statistics. If omitted, netstat will print the current
           configuration information once.

L:\Documents and Settings\admin>

```

Incorrect Answers

A:arp-sadds a new entry to the ARP cache.

B:nbtstat -sdisplays a list of the computer's currently active NetBIOS settings (identifying remote computers by name),

their current status, and the amount of data transmitted to and received from each system.

D:ipconfig /alldisplaysthe full IP configuration of the machine.

QUESTION 468

Consider the following scenario: You receive a call from a user working from a virtual office at home. The office is connected to the corporate site using ADSL through a local ISP. All of the lights on the external DSL modem indicate that it is connected to the CO. A reboot of the modem indicates a normal reconnect to the CO. However, the user is unable to connect to the Internet?

Which of the following represents a possible DSL problem?

- A.The user's phone line is busy.
- B.The DSL access multiplexer is down.
- C.The DSL filter is connected to the modem.
- D.The ISP connection to the DSL access multiplexer is down.

Answer: D

Explanation: Your ADSL modem has a valid connection to the CO. There must be a problem between the CO and the ISP.

Note:CO (Central Office) is where the other end of your copper phone line goes to. The length of this copper limits

your ability to get DSL and at what speed you can connect. The CO is a Building where the phone switching equipment

lives.

Incorrect Answers

A:The usage of the phone line does not directly affect DSL traffic.

B:The cable modem indicates that a connection to the CO is established.

C:DSL filters are placed between your existing phones and the wall where they plug in.They will eliminate any small

whine you may hear on the phone lines when using the internet. A DSL filter does not affect the connectivity.

QUESTION 469

You are the network technician for small office/home office network. You install DSL router on your network as shown in the following exhibit:

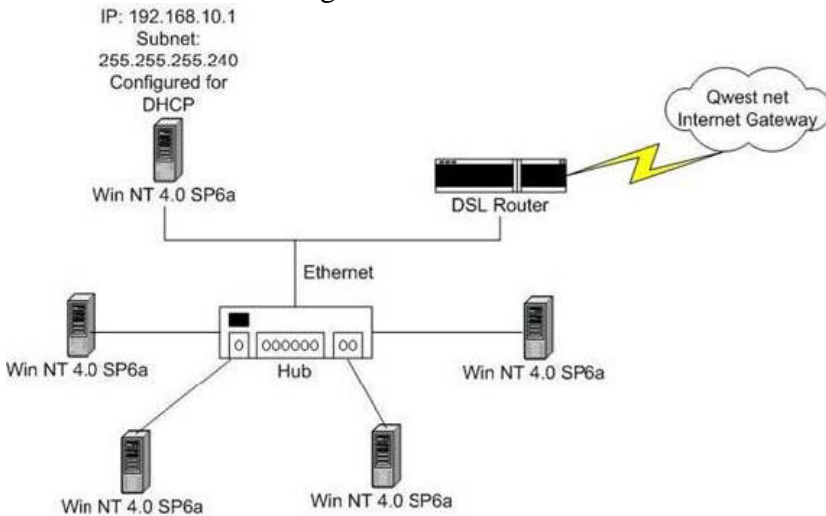

After installing the DSL router, you lose connectivity to your server. You ping the router successfully. You issue the ipconfig command and notice that your workstation's IP address is set to 192.145.15.10.

What is the cause of this problem?

A.The hub is powered off

B.The patch cable between the hub and the DSL router is bad.

C.The patch cable between the hub and the workstation is bad.

D.The DSL Router is also running DHCP, causing a DHCP conflict.

Answer: D

The Workstation has an incorrect IP address. The DHCP server has not been able to configure the client. One possible

cause of this problem could be a second DHCP server running on the network leasing an incorrect IP address.

The other alternatives are very unlikely since the only change of the network is the addition of the DSL router.

QUESTION 470

You have implemented a small home network that consists of three workstations. You intend providing a permanent connection to the Internet for your home network via a DSL router but you are concerned about the threat of hackers gaining access from the Internet. You therefore set up filtering on your DSL router.

After setting up filtering on your DSL router, you discover that you cannot access Internet sites by their Domain Names, but you can access them by their IP addresses. What is the most likely cause of the

problem?

N10-003

- A.You have configured your DSL router to block port 21.
- B.You have configured your DSL router to block port 53.
- C.Your DSL router is not logged in to the ISP.
- D.You do not have IP configured on your client machines.

Answer: B

The DNS service use port 53. Therefore, the most likely cause of the problem is that you have configured your DSL router to block port 53.

QUESTION 471

Consider the following scenario: A switch was added to an office to reduce the collision domain. The switch has been

up and running for a month. Users have called in from this office today and complaining that the network is slow.

What is the appropriate course of action that you would take at this point?

- A.Document the solution.
- B.Implement your solution.
- C.Establish what was changed.
- D.Select the most probable cause.

Answer: C

Explanation: After establishing the symptoms and identifying the affected area we should establish what has changed.

Note:One possible order, within Comptia guidelines, when troubleshooting a network is:

- 1.Establish the symptoms
- 2.Identify the affected area.
- 3.Establish what has changed. (C)
- 4.Establish the probable cause of the problem. (D)
- 5.Formulate a solution.
- 6.Implement a solution. (B)
- 7.Test the solution.
- 8.Recognize potential effects of the solution of the solution.
- 9.Document the problem and solution. (A)
- 10.Give feedback to the users.

Incorrect Answers

A:Documentation is made after the problem is solved.

B:Implementation of the problem requires a solution.

D:To establish the most probable the cause we must first establish what has changed.

QUESTION 472

Servers are rebooting automatically. Upon investigation you find the following: humidity of 40% and a temperature of 95

degrees Fahrenheit. All UPS units are working. What should you do to address the problem of automatic rebooting of

the servers?

- A.Lower the temperature
- B.Increase temperature
- C.No action necessary

Answer: A

Explanation: A too high temperature could cause the server to reboot. We should therefore try to lower the temperature. We could, for example, add extra fans or replace malfunctioning fans.

Incorrect Answers

B:An increased temperature would not improve the situation.

C:We should take some action. Automatic unscheduled reboots of server is unacceptable.

QUESTION 473

Your network uses NetBEUI exclusively.However, you find that traffic is heavy resulting in poor performance.What can you do to improve performance?

- A.Segment the network with a bridge
- B.Use a gateway
- C.Use a repeater
- D.Use a router

Answer: A

Explanation: We could segment the network with a bridge. Bridges work at the data link layer of the OSI model and

are able to contain traffic within a segment.

Note:Broadcasts would still reach the whole network. It might therefore be better to use a router and a routable network protocol. However, that is not an option in this scenario.

Incorrect Answers

B:A gateway is used to transfer between different networkprotocol. But in this scenario only a single network protocol

is used so there would be no use of a gateway.

C:A repeater only regenerates the signal and increases the maximum distance on the network.

D:NetBEUI is not a routable protocol.

QUESTION 474

You are assisting your senior Certkiller technician in extending the Demarc for a new DSL circuit. Which tool should you make use of?

- A.A multimeter
- B.An optical tester
- C.A punch down tool
- D.A bit error rate tester

Answer: C

Explanation: The Demarc is a connection point between the local network and the Telco network. Extending the Demarc is to physically connect the local network with the Telco network. A punch down tool could be of use.

Incorrect Answers

A: There would be no need to test Volt, Resistance etc.

B: To test the cable optically we must first connect it.

D: We would not be required to test the bit error rate.

QUESTION 475

You are the Certkiller network administrator that consists of 10 stations. One workstation experiences problems communicating with the server. The workstation can communicate properly during daylight hours, when the room lights are off. Upon investigation you notice that at night, when the lights are on, the workstation experiences this problem.

What could cause this problem?

A. A bad port on the hub

B. A Voltage drop in the cable

C. Improperly installed cabling

D. User's password has expired

Answer: C

Explanation: There is a cabling problem. There is interference between the network cabling and the power cabling.

Incorrect Answers

A: A faulty port on a hub would not cause this behavior.

B: The problem is constant when the lights are on, not just when the lights are turned on.

D: This is not a problem related to permissions or rights.

QUESTION 476

The following Exhibit displays the scenario:

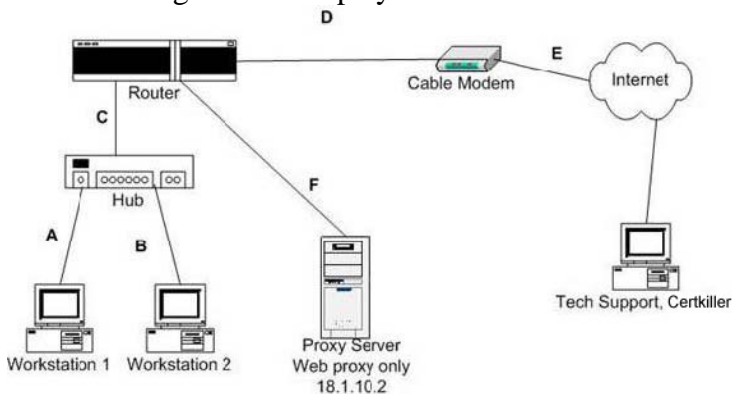

The Certkiller customer reported a loss of Internet connectivity from all their workstations. Tech Support is able to ping

the router but cannot Telnet into it. ICMP port is not open in the router. Which two steps would be useful in troubleshooting this problem? (Choose two.)

A. Restart the router.

N10-003

- B. Replace patch cord C.
- C. Replace patch cord A.
- D. Replace patch cord B
- E. Restart the cable modem.

Answer: A, B

Explanation:

A: The router might be malfunctioning. An indication of this possibility is the fact that Tech Support cannot telnet the router. Rebooting it might resolve the problem.

B: A faulty patch cable between the router and the hub would affect all workstations. It could be the reason of the problems.

Incorrect Answers

C, D: All workstations lost network connectivity, not just some. Just replacing a patch cord between a workstation and a hub would only affect that particular computer connected through that patch cable.

E: We know that the cable modem is operational since Tech Support can ping the router.

QUESTION 477

You were instructed to implement a remote access strategy for the Certkiller network.

Required objectives:

1. Full WAN connectivity.

Optional objectives:

1. Secure connection.

2. Access via Internet Service Provider (ISP).

Proposed solution:

1. Use PPTP.

Which objectives will be met by the proposed solution?

- A. The required and both of the optional results
- B. The required and one optional result
- C. The required and no optional results
- D. None of the objectives are met

Answer: A

Explanation: Point to Point Tunneling (PPTP) protocol can be used to connect different LANs to achieve WAN connectivity (Required objective met).

PPTP use secure tunneling through the WAN media (1st optional objective met).

ISPs provide internet access. PPTP connectivity can be implemented through Internet (2nd optional objective met).

QUESTION 478

Study the Exhibit below carefully.

C:\>tracert Certkiller 1

N10-003

Tracing route to 10.0.0.5 over a maximum of 30 hops

1 <10 ms <10 ms <10 ms router1 [10.0.0.1]

2 <10 ms <10 ms < 10 ms router2 [10.0.0.2]

3***Request timed out

You should have three routers between you and Certkiller 1. Based on the information in the exhibit where should you

start troubleshooting?

- A. Between router1 and router2.
- B. Between router2 and router3.
- C. Between router3 and Certkiller 1.
- D. Between your workstation and router2.

Answer: B

Explanation: The trace is only successful to Router2. We should examine the connection between Router2 and Router3.

Incorrect Answers

A: The trace to Router2 is successful.

C: The trace never reaches router3, but it reaches router2.

D: The trace to Router2 is successful.

QUESTION 479

Study the Exhibit below carefully:

```
C:\ "command" CertkillerSrv
"command" to CertkillerSrv[10.0.0.33]
1 <101 ms <101 ms 100 ms RouterCK1[10.0.0.1]
1 <9 ms <9 ms 9 ms RouterCK2[10.0.0.4]
1 <101 ms <50000 ms 5000 ms RouterCK3[10.0.0.8]
1 <10 ms <10 ms 1 ms CertkillerSrv [10.0.0.33]
"command" complete
```

Users have called your help desk reporting slow responses on an application. You want to check if the network is

responsible for the slowdown.

What does the information in the exhibit convey?

- A. A network delay using tracert
- B. A network delay using ping w
- C. A network delay using netstat a
- D. A normal network response using nbstat

Answer: A

Explanation: TRACERT is used to trace routes throughout the network. In this scenario we see the route from a computer to Certkiller Srv. The route includes the three routers. We also see that traffic is very slow between Router CK2 and Router CK3 .

Incorrect Answers

B: PING only tests connectivity. PING would not show any information on the route, only on the destination.

N10-003

C:Netstat displays current TCP/IP network connections and traffic generated by the various TCP/IP protocols.
D:The nbtstat utility displays protocol statistics and current TCP/IP connections using NBT (NetBIOS over TCP/IP).

QUESTION 480

You are the network technician for small office/home office network. You install DSL router on your network to provide Internet connectivity for the network. The network is shown in the following exhibit:

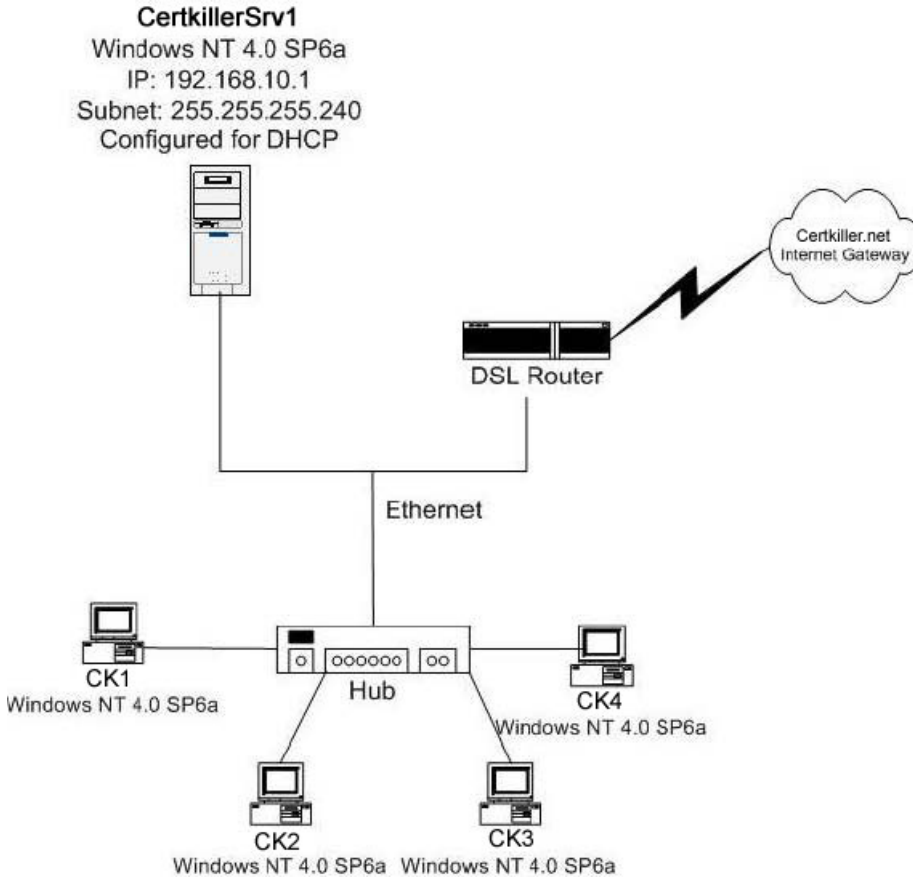

After installing the DSL router, you discover that you cannot access the Internet. You ping the DSL router successfully.

You suspect that the default gateway is not set on the workstation.

Which utility should you use to confirm your diagnosis?

- A.netstat
- B.gateway
- C.ipconfig
- D.winipcfg

Answer: C

Explanation: On Windows NT/Windows 2000/XP systems the IPCONFIG command line utility is used to manage

and display IP configuration. We can use it to verify the default gateway settings.

Incorrect Answers

A:Netstat is a commandline

N10-003

program that displays information about a TCP/IP computer's current network connections and about the traffic generated by the various TCP/IP protocols. It would not be useful in this scenario.

B: There is no Windows utility called gateway.

D: Winipcfg is a GUI that is used for IP configuration on only Windows 9x computers.

QUESTION 481

Exhibit:



Which command was used to produce the output as displayed in the exhibit?

- A. ipconfig
- B. ipcfg
- C. winipcfg
- D. winipconfig

Answer: C

Explanation: The Winipcfg utility has been started on a Windows 9x computer.

QUESTION 482

A user reported that he is unable to connect to the network using Windows 95. You instruct the user to check the IP address.

Which command will you advise the user to run?

- A. winipcfg
- B. ipconfig
- C. winipconf
- D. ipconfig/all

Answer: A

Explanation: In Windows 9x you use winipcfg to configure and manage IP configuration.

Incorrect Answers

B: Ipconfig has the same functionality but only works on Windows NT/2000/.XP systems.

C, D: There are no Windows utilities named winipconf or ipconfig.

QUESTION 483

Which TCP/IP utility is responsible for producing the following sample output?

```
1<10 ms1 ms<10 ms192.168.2.992105 ms92 ms98 msqrvl67terminal01.  
epoch.net [199.24.67.3]3101 ms110 ms98 msqrvl.epoch.net  
[199.24.67.1]4123 ms109 ms118 mssvcr037b.  
epoch.net [199.24.103.125]5123 ms112 ms114 msclsm022.  
epoch.net [199.24.88.26]6136 ms  
130 ms133 msslw19pen610T3.  
sprintlink.net [144.228.116.5]7143 ms126 ms138 msslbb10pen43.  
sprintlink.net [144.232.5.117]8146  
ms129 ms133 msslbb20pen120.  
sprintlink.net [144.232.5.1]9131 ms128 ms139 msslbb20nyc130.  
sprintlink.net [144.232.18.38]10130  
ms134 ms134 msslw9nyc80.  
sprintlink.net [144.232.7.94]
```

- A.PING
- B.NETSTAT
- C.NBTSTAT
- D.TRACERT

Answer: D

Explanation: This output is produced by the TRACERT (tracert) utility. Tracert displays the path that packets take to their destination.

Incorrect Answers

A:PING is only used to test connectivity.

B:NETSTAT displays current TCP/IP connections and information generated by TCP/IP protocols.

C:NBSTAT is used to troubleshoot NetBIOS resolution.

QUESTION 484

Which of the following commands will you use to determine what the workstation's IP address is on an NT4 system?

- A.IP
- B.WINIPCONFIG
- C.IPCONFIG
- D.IPSTAT

Answer: C

Explanation: IPCONFIG is a commandline utility that is used to display and configure IP on Windows NT/2000/XP/.NET computers.

Incorrect Answers

A:IP is a protocol, not a utility.

B:Winipcfg only works on Windows 9x computers.
D:IPSTAT is not a utility for Windows system.

QUESTION 485

How will you go about checking your local TCP/IP connection? (Choose two)

- A.Pinghost
- B.Ping127.0.0.1
- C.Pinglocalhost
- D.Ping127.0.0.0
- E.Pinglocal

Answer: B, C

Explanation: We must ping the local host address. We must either use localhost or the IP address of 127.0.0.1.

QUESTION 486

Which of the following utilities will you advise the Certkiller trainee to use to check the IP configuration on a Windows 95/98 workstation?

- A.NETSTAT
- B.PING
- C.WINIPCFG
- D.IPCONFIG

Answer: C

Explanation: The graphical utility are used on Windows 9x to manage IP configuration.

Incorrect Answers

A:Netstat displays information about the traffic generated by the various TCP/IP protocols.

B:PINGis only used to test network connectivity.

D:Windows NT/2000/XP/.NET machines have the IPCONFIG utility to manage IP configuration. IPCONFIG cannot be run on Windows 9x machines.

QUESTION 487

You are the Certkiller network administrator and have received a complaint by a user regarding the sluggish accessing of a web page on the internet. Which of the following can you use to locate the bottleneck?

- A.TELNET
- B.PING
- C.TRACERT
- D.NBTSTAT

Answer: C

Explanation:

Tracert can be used to trace a route between two devices. The trace includes information connectivity and speed. It would be possible to locate the bottleneck.

Incorrect Answers

A:Telnet is used for remote login.

B:Pingonly tests connectivity.

D:Nbtstat displays information about the NetBIOS over TCP/IP connections. It would be useful to identify

QUESTION 488

You are the network technician for a small IP network. You want to test whether a workstation can reach a remote

server by sending it multiple ICMP echo requests. What utility should you use?

A.ARP

A.PING

B.Ipconfig

C.Winipcfg

Answer: B

Explanation: ThePINGutility is used to test connectivity by sending ICMP echo requests.

Incorrect Answers

A:ARP is used to resolve IP address to MAC addresses.

C:IPConfig is used to configure IP settings on Windows NT2000/XP/.NET computers.

D:Winipcfg is used to configure IP settings on Windows 9x computers.

QUESTION 489

You are the network administrator for your company. Recently, users have begun complaining of slow access speeds to

a server. You suspect that this is the result of a bottleneck on the server.

What utility can you use to isolate the bottleneck?

A.PING

B.TELNET

C.TRACERT

D.NBTSTAT

Answer: C

Explanation: Tracert can be used to trace a route between two devices. The trace includes information connectivity and

speed. It would be possible to locate the bottleneck.

Incorrect Answers

A:Pingonly tests connectivity.

B:Telnet is used for remote login.

D:Nbtstat displays information about the NetBIOS over TCP/IP connections. It would be useful to identify

QUESTION 490

You work as a network technician. Your colleague is troubleshooting a network problem. He issued a command at a command prompt. The output from the command is shown in the following exhibit:

```
Host Name .....:Client1.IDW
DNS Servers .....:
Node Type .....:Broadcast
NetBIOS Scope ID .....:
IP Routing Enabled .....:No
WINS Proxy Enabled .....:No
NetBIOS Resolution uses DNS .....:No

1 Ethernet adapter:

Description .....:3Com Etherlink PCI
Physical Address .....:00-B0-D0-5A-56-EA
DHCP Enabled .....:Yes
IP Address .....:10.0.0.130
Subnet Mask .....:255.255.255.0
Default Gateway .....:
DHCP Server .....:10.0.0.110
Primary WINS Server .....:
Secondary WINS Server .....:
```

What command did your colleague issue?

- A.ipconfig
- B.ipconfig /all
- C.ipconfig /renew
- D.ipconfig /release

Answer: B

Typing ipconfig /all and the command line would produce something very similar to the exhibit.

QUESTION 491

You are the network administrator for your company. Your company has a large network that has a DHCP server assign IP settings to the Windows 2000 workstations. Over the weekend, you split the DNS domain into subdomains.

Users are informed of the change on the following Monday. Some users complain that they are not able to reach the new subdomain locations by host name.

What should you instruct users to do to correct this problem?

- A.Reinstall the TCP/IP stack.
- B.Issue theipconfig /renewcommand.
- C.Issue theipconfig /showclassidcommand.
- D.Configure the subdomains in the IPX/SPX properties dialog box.
- E.Configure the IP address of the subdomain in the TCP/IP properties dialog box.

Answer: B

QUESTION 492

You work as a network technician. Your colleague is troubleshooting a network problem. He issued a command at a command prompt. The output from the command is shown in the following exhibit:

```
C:\WINDOWS\ "command" ServerX

"command" to ServerX[10.0.0.110]
over a maximum of 30 hops:

 1 <10 ms <10 ms <10 ms routerA[10.0.0.6]
 2 <10 ms <10 ms <10 ms routerB[10.0.0.7]
 3 <10 ms <10 ms <10 ms ServerX[10.0.0.110]

"command" complete
```

What command did your colleague issue?

- A.ping
- B.arp a
- C.tracert
- D.nbtstat

Answer: C

The output produced in the exhibit comes from a tracert command. The tracert command shows all the intermediate steps in the path.

QUESTION 493

You are a network technician at your company. You are in the process of troubleshooting a network connectivity problem on a workstation. You want make a loopback plug to test the Ethernet NIC on the workstation.

Which sets of pins should you connect when creating a hardware loopback plug? (Choose all that apply.)

- A.1 and 2
- B.1 and 3
- C.2 and 5
- D.2 and 6
- E.3 and 4
- F.3 and 5

Answer: B, D

In a loopback plug, pin 1 should be connected to 3, and pin 2 should be connected to pin 6.

QUESTION 494

You are connecting a new client machine to a local subnet. You connect to the network, but get the following Windows NT error message:

"Your default gateway does not belong to one of the configured interfaces."

What should you do?

- A.run the tftp command
- B.run the ping command
- C.run the nbtstat command
- D.run the tracert command
- E.run the ipconfig command

N10-003

Answer: E

The default gateway has been misconfigured. The default gateway setting is an IP configuration setting. The Ipconfig command line utility can be used to change the IP configuration parameters.

QUESTION 495

You are a network technician at your company. Your company has a small network that includes several Apple workstations. AppleTalk is enabled on the network to support these workstations. What protocol is responsible for mapping addresses to physical addresses in AppleTalk?

- A.AFP
- B.ARP
- C.AARP
- D.ARAP

Answer: C

AppleTalk Address Resolution Protocol (AARP) maps AppleTalk addresses (network and node numbers) into LAN hardware addresses (for example, Ethernet or token ring addresses), and manages the process of each AppleTalk node acquiring its unique AppleTalk address on these media.

QUESTION 496

You are a network technician at your company. Your company has a small IP network. What protocol is responsible for mapping IP addresses to layer 2 addresses on your company's network?

- A.IP
- B.TCP
- C.UDP
- D.ARP

Answer: D

ARP maps IP addresses to MAC addresses.

QUESTION 497

You work as a network technician. You are troubleshooting a network problem. You want to view a table that contains IP address to MAC address resolutions. What command must you use?

- A.arp
- B.ping
- C.tracert
- D.netstat

Answer: A

The arp command with the a switch displays the current ARP entries (IP address to MAC entries).

QUESTION 498

You work as a network technician. Your colleague is troubleshooting a network problem. He issued a

N10-003

command at a command prompt. The output from the command is shown in the following exhibit:

```
C:\WINDOWS>"command" 10.0.0.131

"command" 10.0.0.131 with 32 bytes of data:

Reply from 10.0.0.0.131:bytes=32 time<10ms TTL=120
Reply from 10.0.0.0.131:bytes=32 time<10ms TTL=120
Reply from 10.0.0.0.131:bytes=32 time<10ms TTL=120
Reply from 10.0.0.0.131:bytes=32 time<10ms TTL=120

"command" statistics for 10.0.0.131:
  Packets Sents = 4, Received = 4, Lost = 0 (0% loss),
Approximate round trip times in milli-seconds:
  Minimum = 0ms, Maximum = 0ms, Average = 0ms
```

What command did your colleague issue?

- A. ping
- B. tracert
- C. nbstat
- D. traceroute

Answer: A

The ping command would produce such an output.

QUESTION 499

You work as a network administrator for a small company. The company has a network that is connected to a remote network via WAN links. The company's network is shown in the following exhibit

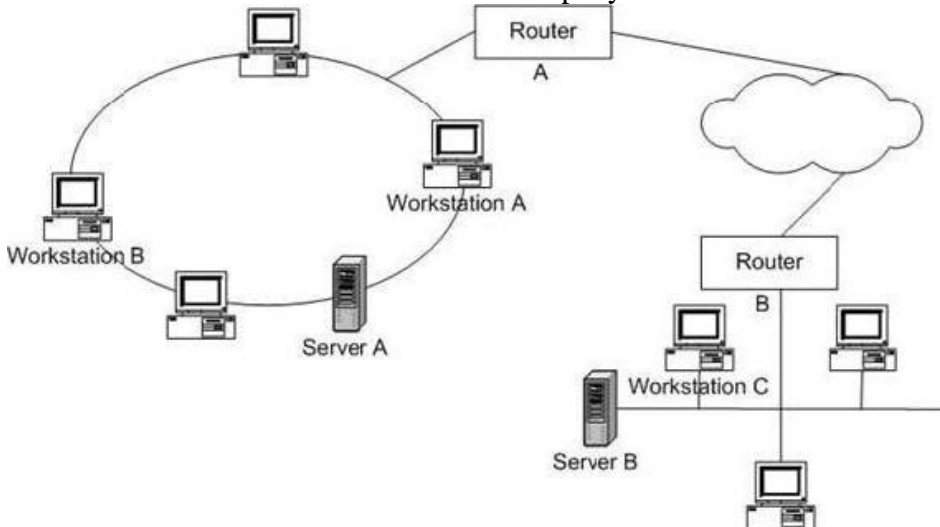

The user of Workstation C complains that he cannot access Server

A. You successfully ping Server B from Workstation C. You ascertain from a colleague that Workstation A can access Server A. You now need to narrow down the location of the network failure. Which command should you issue at Workstation C to accomplish this?

- A. Ping Router A
- B. Tracert Server A
- C. Tracert Router A

D.Ping Workstation A

Answer: B

The output of the tracert ServerA command would indicate where the problem occurred (on Router B, on Router A, or on ServerA).

QUESTION 500

Prior to being moved to a new network with Internet access, a user was able to log in to the main Windows NT server

and access the Internet. The user is now unable to access the Internet or the file server.

What is the cause of the problem?

A.DLC needs to be installed on the workstation.

B.IPX needs to be installed on the workstation.

C.DHCP needs to be disabled and a static IP address needs to be assigned.

D.NetBEUI automatic configuration needs to be disabled and a static NetBEUI address needs to be assigned.

Answer: C

Explanation: Correct IP address assignment is required to gain access to Internet. IP configuration is either obtained

dynamically from a DHCP server or configured statically.

Incorrect Answers

A, B, D:The IPX, DLC, or NetBEUI protocols are not used to gain Internet access. Internet uses the TCP/IP protocol.

QUESTION 501

You have sent an email

to user@email.us. Your email address is me@mydomain.com. In what order are the domain names for this email resolved?

A.com, us, email.us, mydomain.com

B.mydomain.com, com, us, email.us

C.com, mydomain.com, us, email.us

D.email.us, mydomain.com, com, us

Answer: B

This is correct order in which email domain names are resolved.

QUESTION 502

You work as a network technician. Your colleague is troubleshooting a network problem. He issued a command at a command prompt. The output from the command is shown in the following exhibit:

```
Active Connections

Proto Local Address Foreign Address State
TCP dell-45:137 DELL:0 LISTENING
TCP dell-45:1026 DELL:0 LISTENING
TCP dell-45:1031 DELL:0 LISTENING
TCP dell-45:137 DELL:0 LISTENING
TCP dell-45:1031 Server5:1433 ESTABLISHED
TCP dell-45:137 DELL:0 LISTENING
TCP dell-45:138 DELL:0 LISTENING
TCP dell-45:nbssession DELL:0 LISTENING
TCP dell-45:11487 DELL:0 LISTENING
TCP dell-45:1025 DELL:0 LISTENING
TCP dell-45:1027 DELL:0 LISTENING
UDP dell-45:nbname *: *
UDP dell-45:nbdatagram *: *
UDP dell-45:11487 *: *
```

What command did your colleague issue?

- A.nbtstat
- B.network
- C.netstat a
- D.network a

Answer: C

This command shows the state of all sockets.

The aoption

tells netstat to show you the status of all open sockets on a machine.

QUESTION 503

You are the administrator of your company's network. The network consists of two segments called Network A and Network B. Network A is IP network 192.168.1.0/24 and Network B is IP network 192.168.2.0/24. One router connects Network A to Network B using IP only. Both networks use various machines, including Windows NT machines, Linux machines, and NetWare servers. Every machine on the network needs to be able to see every other network machine using host names.

Which technologies should you install to achieve this functionality? (Choose all that apply.)

- A.DNS
- B.WINS
- C.DHCP
- D.TCP/IP
- E.IPX/SPX

Answer: A, D

A:The TCP/IP suite of protocols is supported by Windows, Linux, and NetWare.

D:To support host to IP address resolution we used DNS.

Incorrect Answers

B:WINS is used for NetBIOS names, not host names.

C:DHCP is used to assign network addresses on an IP network.

E:Linux does not support IPX/SPX.

QUESTION 504

The new Certkiller trainee technician wants to which of the following represents the best strategy for implementing a continuous power supply. What will your reply be?

N10-003

- A.UPS
- B.SPS
- C.CPU

Answer: A

Explanation: Unlimited Power Supply (UPS) units is a good strategy to protect against disruptions of the power source.

An UPS could provide supply for some hours, if the main power supply is down.

Incorrect Answers

B:SPS does not apply here.

C:The central processor (CPU) only consumer power. It cannot provide power.

QUESTION 505

You work as a network consultant. You are hired to design and build a network for a new company. Which procedures

should you implement before implementing any new network? (Choose all that apply.)

- A.Disable all network logins.
- B.Compile detailed documentation.
- C.Implement network load balancing.
- D.Determine needs and expectations.

Answer: B, D

Explanation:

B:Solid documentation of the network implementation will be beneficial later on.

D:Needs and expectations should always be considered before implementing a network.

Incorrect Answers

A:In general, it is not necessary to disable network logins.

C:Load balancing is only required to increase performance.

QUESTION 506

You are the network technician for small office/home office network. Your network utilization spikes and stays at a high level.

What would your first troubleshooting step be in resolving this problem?

- A.Isolate the faulty node
- B.Verify problem resolution
- C.Isolate the faulty cable section
- D.Isolate the faulty network segment
- E.Isolate the faulty transceiver, transceiver cable, or NIC

Answer: D

First we should isolate the network segment in order to find the faulty device.

QUESTION 507

You are building a network in which every node will have a physical path to at least three nodes. What network

topology are you using?

- A.bus
- B.ring
- C.star
- D.mesh

Answer: D

In a mesh topology every node is connected to three or more other nodes.

QUESTION 508

Which piece of information is necessary to obtain root access to resources on a Linux system?

- A.The username
- B.The password
- C.The email address
- D.The domain name

Answer: B

Explanation: A password is required to obtain root access.

QUESTION 509

Which of the following statements regarding user level security is valid?

- A.The user of each machine can decide which resources from the machine are made available to other users on the network.
- B.The user of each machine can decide which resources from the network server are made available to other users on the network.
- C.The network administrator can decide which resources are made available to other users on the network.
- D.The network administrator can decide which resources are made available to other users outside the network.

Answer: C

Explanation: User level security is managed centrally from a server by the network administrators. The network administrators assign permissions for resources on the network to users and groups.

Incorrect Answers

A, B:User level security is managed centrally from a server, not locally on the workstations.

D:User level permissions only apply within the network, not outside it.

QUESTION 510

Maria, who works in the Certkiller finance department, reports to you that she cannot print to the network printer. She

is member of a group who has the correct permissions to print.

However,all other users of the same group can print to the printer.What is the problem?

- A.Her user access permissions are set wrong

N10-003

- B. Her printer domain is set wrong
- C. Her share access is set wrong

Answer: A

Explanation: To be able to print you must have print permission (access permission) to the printer.

Incorrect Answers

B: The term printer domain does not apply.

C: Share access permissions are used to configure permissions for folders and files that are shared, and not for sharing printers.

QUESTION 511

Which of the following regarding user level security is valid?

- A. It has less permissions than share level security
- B. Permissions are assigned to resources
- C. It is centrally administrated

Answer: C

Explanation: User level security is centrally configured on a server.

Incorrect Answers

A: Share level security has less permissions compared to user level permissions.

B: Permissions are assigned to users and groups.

QUESTION 512

Of the following possibilities which would you recommend to use as a more secure choice for a user password?

- A. Uone
- B. UserO
- C. Password
- D. User\$one

Answer: D

Explanation: It is best to mix alphanumerical and non alphanumerical letters. The length of the password is also important.

Incorrect Answers

A: Too short and only alphanumerical letters.

B: Too short.

C: Only alphanumerical letters.

QUESTION 513

You are the network administrator at your company. You suspect that someone has been trying to access your company's network. You want to ensure that only authorized users can access the network and decide to implement a

N10-003

more secure password policy.

What can you do to make your password policy more secure?

- A. Set password expiration to 3 days.
- B. Make scheduled password changes regularly.
- C. Require users to change passwords randomly.
- D. Require passwords with a random number of characters.

Answer: B

Explanation: Password should not be kept constant. By changing the passwords regularly security is enhanced.

Incorrect Answers

A: Two days is too short time. Also the password changes should be scheduled on a regular basis.

C: Users should not change passwords randomly. By using password policies you can force users to, for example, a

minimum password length and passwords that contain both letters and numerals.

D: A minimum number of characters should be required.

QUESTION 514

Which of the following are good password practices? (Choose all that apply.)

- A. Keep passwords indefinitely.
- B. Change passwords every 90 days.
- C. Maintain minimum password length.
- D. Use only alphanumeric symbols in passwords.

Answer: B, C

Explanation:

B: Passwords should be changed regularly.

C: A minimum password length strengthens security.

Incorrect Answers

A: Passwords should be changed regularly.

D: A password should be a mixture of alphanumeric and numbers. It makes it much harder to guess the passwords.

QUESTION 515

You are a network administrator at Certkiller, Inc. Certkiller users have access to a number of applications on a server. They use these applications in the course of their work. A user complains that she cannot access one of the applications but she can access the other applications. Other users can access all the applications.

What would your first step be to resolve this problem?

- A. Reboot the server
- B. Restart the application
- C. Reset the user's password
- D. Reboot the user's workstation
- E. Check the user's access permissions
- F. Ask the user to access the application from another workstation

N10-003

Answer: E

Explanation: Either it is a problem with this computer or it is a problem with the user account. By trying from another

computer we can eliminate one of the causes.

Incorrect Answers

A:The application is functioning at the server. It can be accessed from other workstations.

B:Rebooting is often a useful practice when troubleshooting. However, other applications on the server work on the workstation.

C:The user is able to access the server through another application. Apparently he is logged in to the network

D:There is no such notation called access procedures.

QUESTION 516

You are implementing Windows NT permissions. Which of the following permissions can you assign to users and

computers? (Choose all that apply.)

A.list

B.read

C.write

D.change

Answer: A, B, C

There is no change permission in an NT/2000/XP environment. Instead it is called Modify permission.

QUESTION 517

You are the network administrator for your company. Your company has a domainbased network. You want t

implement user level security on the network.

How does user level security differ from share level security in such an environment?

A.More privileges can be set.

B.One password is used for everyone to connect.

C.Multiple accounts and privileges are centrally administered.

D.Privileges and rights cannot be changed on a casebycase basis.

Answer: C

User level security allows a centrally managed security administration.

QUESTION 518

You are a network administrator at Certkiller ,Inc. Certkiller users have access to two applications on a server. They use these applications in the course of their work. A user complains that she cannot access one the applications. She can access the other application. Other users can access both applications.

You need to resolve this problem. What would your first step be?

A.Reboot the server

B.Restart the application

N10-003

- C.Reset the user's password
- D.Reboot the user's workstation
- E.Check the user's access permissions
- F.Ask the user to access the problem application from another workstation

Answer: E

Since the user can access resources on the server we should check the access permissions.

Incorrect Answers

A:The server is functioning correctly as other users can access all the applications.

B:The application is functioning on the server as it can be accessed from other workstations.

C:The user is able to access the other applications on the server. Therefore, there cannot be something wrong with the user's password.

D:The user is able to access other resources on the Rebooting is often a useful practice when troubleshooting. However, other applications on the server work on the workstation.

F:The user might be able to access the application form another workstation, but this does not really solve the problem.

QUESTION 519

You work as the network administrator for a large company. Users in the Accounts Department store accounts data on

a file server. All users in the Accounts Department are able to view and modify this data. A new employee joins the

Accounts Department. The new employee complains that he can view the accounts data but cannot save changes.

Other users in the Accounts Department can save their changes.

What is the cause of the problem?

- A.Bad patch cable
- B.Accounts data is corrupt
- C.Insufficient user permission
- D.Bad user name and password

Answer: C

The user has permission to view (=list) the data, but is not able to access (=open) it.

QUESTION 520

Which of the following security circumstances will you find most restricting?

- A.User level access
- B.Share level access
- C.None of these

Answer: A

Explanation: User level security is more granular than share level security. Furthermore, as user level security implements centralized security which enables a more restrictive network wide security approach.

QUESTION 521

You received a complaint by a user who is unable to log onto a server. As the Certkiller network technician which

troubleshooting steps should you take to resolve the problem? (Choose three)

- A. Ask a user on the same segment to try and connect.
- B. Ask a user on a remote segment to try and connect.
- C. Replace the NIC.
- D. Try and ping the server.

Answer: A, B, D

Explanation:

A, B: We could ask other users, either on the same segment or on remote segment, to try and connect. This could help

us to localize the problem.

D: We should see if we have connectivity between the client computer and server.

Incorrect Answers

C: If we localize the problem to the computer and exclude configuration problem we could consider replacing the NIC.

However, we should try to find simpler solution first.

QUESTION 522

Tom is trying to back up data to a DLT tape drive. He receives an error message that the tape drive is not available, this

occurs even if Tom tries a new cartridge. How will you address Tom's problem in an effort to resolve it?

- A. Replace the tape drive
- B. Replace the cable
- C. Replace the adapter card
- D. Put a tape cleaner into the drive

Answer: D

QUESTION 523

The new Certkiller trainee technician wants to know which type of IP routing incorporates RIP. What will your reply be?

- A. CRC
- B. Static
- C. Dynamic
- D. Circular

Answer: C

Explanation: RIP uses dynamic routing. Dynamic routing is when the routers exchange routing information automatically. Dynamic routing enables the routers to build their own routing tables.

Incorrect Answers

A: CRC is used to detect errors in data.

N10-003

B:Static routing does not involve any routing protocol. The administrator must manually add the appropriate routes into the routing table.

D:There is no such thing as circular routing.

QUESTION 524

You encounter a situation where computers are rebooting spontaneously. Upon investigation you find that the room is cold and space heaters are used. What is the problem?

- A.Bad UPS
- B.Bad NICs
- C.Bad wiring
- D.Voltage drop at the outlet

Answer: D

Explanation: Uneven voltage, spikes, sags, or brownouts, could cause computers to reboot spontaneously. An UPS could solve the problem at hand.

Incorrect Answers

A: ~~This could be a cause of~~

B:Bad NICs is not the most likely cause of this problem.

C:Bad wiring could be the cause of the problem, but it is not the most likely cause.

QUESTION 525

Which of the following concepts have the same meaning? (Choose two.)

- A.ROM
- B.RAM
- C.firmware
- D.hard drive space
- E.freeware

Answer: A, C

Explanation: Firmware consists of programs installed semipermanently into memory, using various types of programmable ROM chips. So we can say that the concepts of Firmware and ROM are connected, though they are not

strictly synonymous.

Incorrect Answers

The other terms are not directly connected to each other.

QUESTION 526

Consider the following in a scenario where you find that you are unable to connect to the server:

*The light in the back of the NIC is not flashing.

*You change the patch cable and it is still not flashing.

N10-003

*You go into the wiring closet and switch the connector from one connection on the hub to another. You check the NIC

light and it is blinking.

What should you do next?

- A. Replace the NIC
- B. Replace the HUB
- C. Log in and try to transfer a file
- D. Replace the cable

Answer: C

Explanation: The light on the NIC is blinking. This indicates that the NIC is able to communicate with the hub. We

should try the connection, for example by trying to transfer a file.

Incorrect Answers

The NIC and the hub have physical connectivity. We should try it works, and there is no need to replace anything at this point.

QUESTION 527

Which of the following represents a disadvantage when making use of a bus topology on a 100 user network?

- A. It is prone to cable faults
- B. It requires expensive cabling
- C. You are compelled to terminate each node

Answer: A

Explanation: A single bus segment is a single point of failure. If the cable is broken in just a single point, the whole network would go down. It would be better to separate the network into several interconnected network segments.

Incorrect Answers

B: Bus topology requires less cabling than star topology for example.

C: A bus must only be terminated at both ends, not at each node.

QUESTION 528

You have just built a small home network that is connected to the Internet via a modem. You, however find that you

cannot connect to Host X from your workstation.

A visual examination of your network card, your hub, your router and your modem reveals that the collision light on the

hub is steadily lit.

Your network is shown in the following exhibit:

N10-003

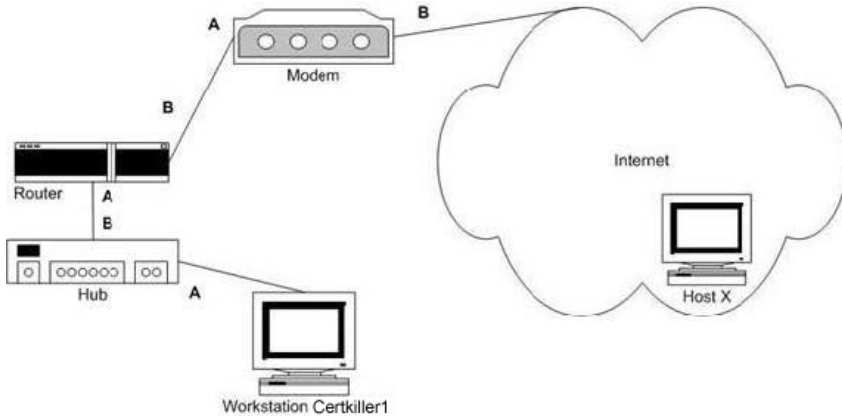

What component is the most likely cause of this problem?

- A. A chattering NIC in Host X.
- B. A chattering NIC in the workstation.
- C. A bad patch cable between the modem and Host X.
- D. A bad patch cable between the router and the modem.

Answer: B

Explanation: A chattering NIC on the workstation would result in heavy traffic on the trunk between the workstation and the hub. This could result in collisions and network performance would be decreased.

Incorrect Answers

- A: Host X is not directly connected to the hub.
- C: The modem or Host X are not directly connected to the hub.
- D: The segment between the router and the modem is not directly connected to the hub.

QUESTION 529

All users on the network CANNOT connect to the server for the last 15 minutes. The server is unable to ping any of the workstations or its own loopback address even after a reboot.

Which statement is true?

- A. The server's NIC has failed.
- B. The DHCP server needs to be restarted.
- C. All clients need to be rebooted.
- D. The DNS server needs to be restarted.

Answer: A

Explanation: The loopback address is used to test the network interface card (NIC). This test has failed and we know that the NIC is the cause of the problems. The NIC could have failed.

Incorrect Answers

The NIC is the source of the problem, not the clients or any network service.

QUESTION 530

Study the Exhibit below carefully:

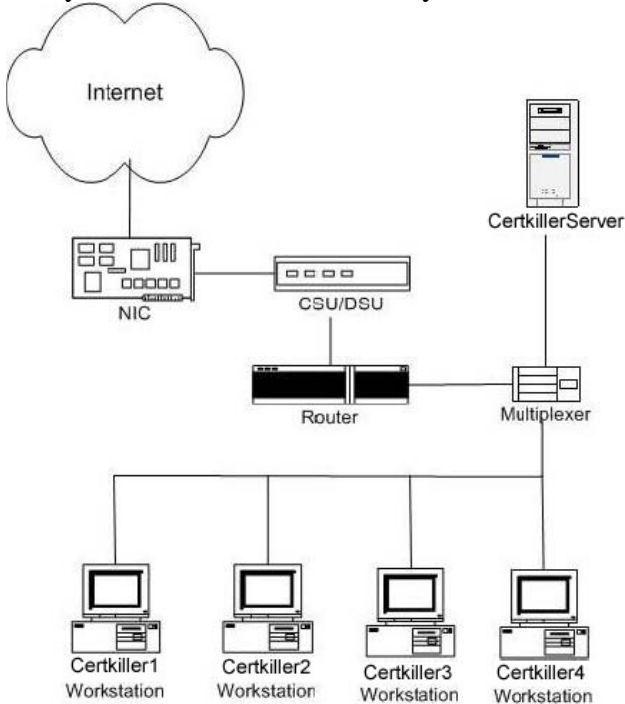

The WAN connection for Certkiller is provided by the Local Exchange Carrier (LEC). The LEC is capable of looping and tests good to the Network Interface (NIC), but not to the CSU/DSU.

What can cause the LEC to not loop the CSU/DSU?

- A.Router not configured to route.
- B.A bad cable pair from the CSU/DSU to the NIC.
- C.Workstations not configured with a default gateway.
- D.A bad cable pair from the router to the CSU/DSU.

Answer: B

Explanation: The connection between the service provider, which is located at the Internet, and the NIC is good, but the service provider cannot access the CSU/DSU: Some problem occurs between the NIC and the CSU/DSU. A bad cable between them is a possible cause of the problem.

Incorrect Answers

A,C,D:The router or the workstations are not in the path between the service provider and the CSU/DSU. The service provider is located at the Internet.

QUESTION 531

A user is unable to log on to the network. What is your first step that you will advise the Certkiller trainee technician to take to resolve the problem?

- A.Replace the NIC.
- B.Reboot the workstation.

N10-003

- C.Reinstall the network client software.
- D.Determine if other users can log on.

Answer: D

Explanation: We should try to determine the scope of the problem. We should check if other users have the same problem.

Incorrect Answers

A:We should not replace the NIC until we have examined the problem further.

B:Rebooting the system is a standard procedure. However, it would be better to check if other users can log on to the network.

C:We should wait with re-installing the network client software until we have determined the cause of the problem.

QUESTION 532

Which of the following statements explains the rationale behind subnetting an IP network? (Select two)

- A.You want to reduce congestion.
- B.You need to connect multiple media types.
- C.You want to optimize your IP address space.
- D.You want to remove a router from your network.

Answer: A, C

Explanation:

A:Subnetting reduces congestion by making traffic local within the respective subnets.

C:Subnetting optimizes the utilization of the IP address space.

QUESTION 533

A newly appointed Certkiller trainee technician has been instructed to install a NIC in a workstation. The hub where the workstation is connected is now not working anymore.

What are two possible causes for this problem? (Select two)

- A.Faulty cable
- B.Incorrect DMA setting
- C.Incorrect IRQ number
- D.Incorrect data transfer rate

Answer: A, D

Explanation:

A:A faulty cable between the NIC and the hub might affect the hub.

D:Incorrect data transfer rate on the NIC might affect the hub.

Incorrect Answers:

B, C:DMA and IRQ settings of the NIC would not affect the hub.

QUESTION 534

Study the Exhibit below carefully:

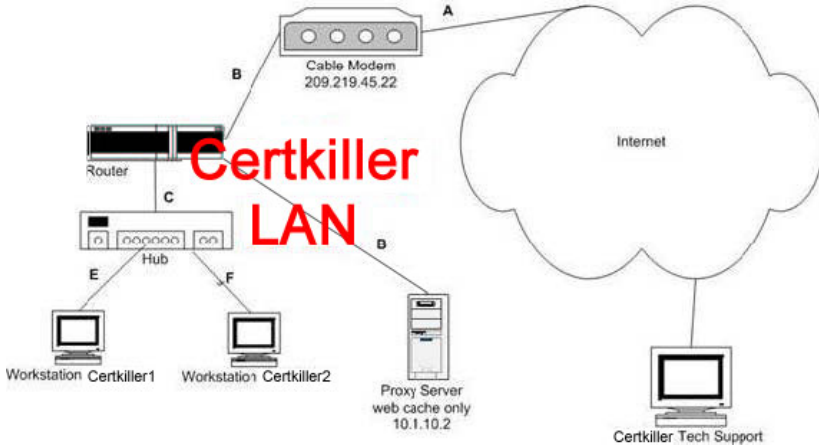

Certkiller technical support calls and informs you that they can no longer connect to the proxy server on your network.

After performing a visual inspection you discover that the link lights on the NIC in the proxy server and the router are

out. All other link lights are lit.

Which of the following components is the most likely cause of this problem?

- A.hub
- B.bad cable
- C.cable modem
- D.NIC in workstation 1

Answer: B

Explanation: There is no physical connection between the Router and the Proxy server. This is indicated by the lights

on the NICs in the proxy server and in the router, which both are out.

Incorrect Answers:

A, C, D:The hub, the cable mode, and the NIC in a workstation do not affect the connectivity between the router and the Proxy Server.